



Australian Government
**National Measurement
Institute**

Bradfield Road, West Lindfield NSW 2070

Cancellation
Certificate of Approval No 10/1/19

Issued by the Chief Metrologist under Regulation 60
of the
National Measurement Regulations 1999

This is to certify that the approval for use for trade granted in respect of the
Compac Model Legend MD2LPG LPG Fuel Dispenser for Motor Vehicles
submitted by Compac Industries Ltd
 52 Walls Road
 Penrose Auckland New Zealand

has been cancelled in respect of new instruments as from 1 November 2010.

Signed by a person authorised by the Chief Metrologist
to exercise his powers under Regulation 60 of the
National Measurement Regulations 1999.

A handwritten signature in black ink, consisting of a series of loops and a long horizontal stroke at the bottom.

10/1/19
6 May 2004



Australian Government

National Standards Commission

12 Lyonpark Road, North Ryde NSW 2113 Australia

Certificate of Approval

No 10/1/19

Issued under Regulation 60
of the
National Measurement Regulations 1999

This is to certify that an approval for use for trade has been granted in respect of the

Compac Model Legend MD2LPG LPG Fuel Dispenser for Motor Vehicles

submitted by Compac Industries Ltd
 52 Walls Road
 Penrose Auckland
 New Zealand.

NOTE: This Certificate relates to the suitability of the pattern of the instrument for use for trade only in respect of its metrological characteristics. This Certificate does not constitute or imply any guarantee of compliance by the manufacturer or any other person with any requirements regarding safety.

CONDITIONS OF APPROVAL

This approval becomes subject to review on 1 March 2009, and then every 5 years thereafter.

Instruments purporting to comply with this approval shall be marked NSC No 10/1/19 and only by persons authorised by the submitter.

Instruments purporting to comply with this approval and currently marked NSC No P10/1/19 may be re-marked NSC No 10/1/19 but only by persons authorised by the submitter.

It is the submitter's responsibility to ensure that all instruments marked with this approval number are constructed as described in the documentation lodged with the Commission and with the relevant Certificate of Approval and Technical Schedule. Failure to comply with this Condition may attract penalties under Section 19B of the National Measurement Act and may result in cancellation or withdrawal of the approval, in accordance with the Commission's Document NSC P 106.

The Commission reserves the right to examine any instrument or component of an instrument purporting to comply with this approval.

Auxiliary devices used with this instrument shall comply with the requirements of General Supplementary Certificate No S1/0/A.

DESCRIPTIVE ADVICE

Pattern: provisionally approved 18 June 2002
approved 20 February 2004

- A Compac model Legend MD2LPG dual fuel dispenser for refuelling motor vehicles using liquefied petroleum gas (LPG).

Variant: provisionally approved 18 June 2002
approved 20 February 2004

1. Certain models of the Premier and Laser series.

Technical Schedule No 10/1/19 describes the pattern and variant 1.

FILING ADVICE

The documentation for this approval comprises:

Certificate of Approval No 10/1/19 dated 6 May 2004
Technical Schedule No 10/1/19 dated 6 May 2004 (incl. Test Procedure)
Figures 1 to 10 dated 6 May 2004

Signed by a person authorised under Regulation 60 of the National Measurement Regulations 1999 to exercise the powers and functions of the Commission under this Regulation.



TECHNICAL SCHEDULE No 10/1/19

Pattern: Compac Model Legend MD2LPG LPG Fuel Dispenser for Motor Vehicles

Submitter: Compac Industries Ltd
52 Walls Road
Penrose Auckland New Zealand

1. Description of Pattern

The Compac model Legend MD2LPG (Figures 1 and 2) is a dual fuel dispenser for refuelling motor vehicles using liquefied petroleum gas (LPG). The dispenser is approved for use in attendant-operated mode or in attended self-service mode when interfaced to a compatible (#) Commission-approved fuel dispenser controller.

(#) "Compatible" is defined to mean that no additions/changes to hardware/software are required for satisfactory operation of the complete system including all checking facilities.

1.1 Field of Operation

The field of operation of the measuring system is determined by the following characteristics:

- Minimum measured quantity, V_{min} 2 L
- Maximum flow rate, Q_{max} 40 L/min
- Minimum flow rate, Q_{min} 8 L/min
- Maximum operating pressure (P_{max}) 2400 kPa
- Ambient temperature range -25°C to 55°C
- LPG density in the range 510 kg/m³ to 570 kg/m³ (at 15°C)
- Volume conversion to 15°C over a liquid temperature range of -10°C to 50°C
- Delivered volume is converted to 15°C

1.2 System Description

(i) Supply Tank and Pump

The supply tank is fitted either with an internal submersible pump or with an external multi-stage turbine pump. In the latter case the pump is located below the lowest liquid level in the supply tank, which may be defined by a liquid low-level detection device. The pump(s) shall be of sufficient capacity rating such that when all nozzles are in use, the flow rate of each nozzle is maintained above the specified minimum flow rate.

For verification/certification of the LPG dispenser, a vapour return line is installed between the fuel dispenser and the supply tank with no intermediate flow restrictive devices. At the fuel dispenser, the vapour return line incorporates an appropriate connector and check valve to allow an LPG nozzle to be connected for circulating LPG back to the supply tank.

(ii) Gas Elimination Devices

Each flowmeter is protected from the measurement of vapour by a Compac model VAPCOM vapour eliminator/filter (Figure 3) with built in check and internal relief valve. The gas elimination device allows a continuous bleeding of LPG and any vapour back to the vapour space of the supply tank via a vapour return line of not less than 20 mm in diameter.

The gas elimination device also has provision for inserting a reference thermometer for verification of LPG temperature measurement.

(iii) The Measurement Transducers

Each measurement transducer is a Compac model COM50-LPG sliding vane positive displacement LPG flowmeter (Figure 4) fitted with a Compac magnetic tri-channel encoder producing approximately 500 pulses/litre. The rotor of the meter is designed to rotate approximately 20 revolutions for a throughput of one litre.

Provision is made to fit a pressure gauge for the measurement of meter pressure during verification/certification.

To adjust the meter calibration, use the configuration K-factor switch until the Price display indicates 'F ' for a single dispenser, or either 'Fa' or 'Fb' for a dual dispenser (side a, side b), and enter the new K-factor. The new K-factor is calculated using the following equation:

$$\text{new K-factor} = \text{existing K-factor} \times (\text{Reference volume} / \text{Fuel dispenser volume})$$

(iv) Pressure Differential Valve

A Compac model DIFFVALVE spring-loaded pressure differential valve (Figure 5) producing a backpressure of at least 100 kPa above vapour pressure, is fitted to the outlet of each flowmeter. A pressure-equalising pipe is connected from the top of the differential valve to the vapour space of the supply tank.

(v) Solenoid Valve

A solenoid-operated valve is installed downstream of the pressure differential valve to control the main flow of LPG. An optional slow-flow solenoid-operated valve may also be installed in parallel with the main valve to allow pre-set control of the delivery. Between the solenoid-operated valves and the delivery hose, an isolating valve is installed with a pressure relief device and an excess flow valve.

(vi) Calculator/Indicators

Each Compac model C4000 calculator/indicator (Figure 6) incorporates:

- Software version 29193;
- Volume conversion for temperature;
- Price, volume and unit price displays; and
- Optional pre-set facility (keypad and display).

The indicators display the following maximum values:

Volume	000.00 L to 999.99 L in 0.01 L increments
Unit price	0.001 to 9.999 \$/L in 0.1 c/L increments
Price	\$000.00 to \$999.99 in 1 c increments

The optional pre-set facility allows pre-set values to be entered in dollar increments up to a maximum of \$999.

During pressurisation the instruments may inhibit displaying the volume for the first 80 mL of any delivery.

A non-resettable electro-mechanical volume totaliser is provided for each hose. The totaliser indicates the accumulative volume at 15°C dispensed by the instrument. The totaliser is located above the Dollars display. The totaliser displays a maximum value of 9999999 litres.

On instruments incorporating a pre-set keypad, the calculator/indicator can display the electronic totals by pressing the CLEAR button five times in quick succession.

(vii) The Transfer Device

The transfer device is an Elaflex model ZVG LPG nozzle or Gogas model Sealmaster LPG nozzle (with holster as shown in Figure 6) or any other compatible Commission-approved LPG nozzle that cannot be replaced in a hung-up position other than to end the delivery. The nozzle is connected to an Elaflex model DIN4815/3 hose, or any other compatible hose complying with the relevant Australian Standards for LPG. A break-away coupling and an excess flow valve may be fitted to the hose.

(viii) Volume Conversion Device

The volume conversion for temperature device comprises:

- A Compac model C4000 calculator/indicator interfaced to a temperature/density circuit board part number F-CP-DENS-CI155;
- A Compac model DENSITYSEN-LPG ultrasonic density sensor;
- A temperature-measuring device, identified by part number F-CU-LPG-TEMP-SEN; and
- A Betatherm model 5K3A1 temperature sensor element.

The instrument measures the temperature and density of LPG and the metered volume is converted to volume at 15°C based on ASTM-IP-API Petroleum Measurement Tables for Light Hydrocarbon Liquids, metric edition, Table 54 and Table 53.

To adjust temperature and/or density, use the configuration K-factor switch until the Price display indicates 'E' to calibrate temperature measurement or until the Price display indicates 'dEn' to calibrate density measurement.

(ix) Checking Facilities

The instrument incorporates the following checking facilities:

- A segment check is performed on all segments when a delivery is commenced.
- When error 3 is displayed, a unit price is required to be set on the dispenser.
- If error 7 is displayed, the meter is exceeding the maximum flow rate.
- Error 9 indicates that the encoder is either faulty or is disconnected.
- Error 10 displayed means a memory failure has occurred on the EPROM of the C4000 calculator/indicator and will need to be changed.
- Error 13 indicates that the temperature interface board is not communicating with the C4000.
- Error 14 is shown if a problem with the temperature measuring device is detected.
- Error 15 indicates that the density sensor has been disconnected.
- “rAnGe” is displayed when the temperature is out of range.
- “dEnEr” is displayed when the density is out of range.

1.3 Markings

Instruments are marked with the following data, together in one location on a data plate:

Pattern approval sign	NSC No 10/1/19
Manufacturer’s identification mark or trade mark
Manufacturer’s designation (model number)
Serial number
Year of manufacture
Maximum flow rate (Q_{max}) L/min
Minimum flow rate (Q_{min}) L/min
Maximum operating pressure (P_{max})	2400 kPa
Minimum pressure (P_{min}) 200 kPa above vapour pressure	(#)
Nature of the liquids to be measured	LPG
Approved for LPG density range	510 kg/m ³ to 570 kg/m ³ (at 15°C)
Accuracy class	class 1.0
Environmental class	class C

(#) Alternatively, the following wording may be used:

“LPG pressure (at the meter) is maintained at least 200 kPa above vapour pressure.”

Note: The words “at the meter” may be deleted to save space.

The minimum measured quantity is marked on the calculator/indicator clearly visible to the user and is marked in the form “Minimum Delivery 2 L”.

1.4 Sealing Provision

Access to the electronic meter calibration switch has provision for sealing as shown in Figure 8.

1.5 Verification/Certification Provision

Provision is made for a verification/certification mark to be applied.

2. Description of Variant 1

Certain other models as listed below:

- Premier model PR-LPG-D dual dispenser (Figure 9);
- Premier model PR-LPG single dispenser;
- Laser model L-LPG-D dual dispenser (Figure 10); and
- Laser model L-LPG single dispenser.

TEST PROCEDURE

Instruments should be tested in conjunction with NSC Test Procedure No 13, *Non-driveway Flowmeters*.

Maximum Permissible Errors at Verification/Certification

The maximum permissible errors applied during a verification test of the fuel dispenser using the liquid for which it is to be verified/certified, and from normal flow rate to the minimum flow rate specified in the Certificate of Approval or Technical Schedule are:

- ±0.6% for the calibration/adjustment of the meter; (*)
- ±1.0% for inservice inspection of the complete measuring system; and
- ±0.4% for the volume conversion for temperature device.

Other applicable maximum permissible errors are:

- ±0.5°C for the temperature measuring device;
- 10 kg/m³ for the density detection device;
- ±40 mL for deliveries equal to the minimum measured quantity; and
- ±1.0% for gas elimination for LPG.

(*) It is forbidden to adjust the calibration of the meter to give an error other than as close as practically to zero.

Calibration/Verification Procedure

Note: For detailed configuration and code setting procedures, refer to the manufacturer's service manual.

- The calibration of the meter is carried out with the dispenser in its normal mode of operation.

- Make a delivery and after the nozzle is hung up, press and release the Parameter switch in quick succession until the uncompensated volume, density (kg/m^3) and temperature ($^{\circ}\text{C}$) are displayed in the Volume (Litres) display, Price (Dollars) display, and Unit Price display, respectively.
- The volume conversion for temperature device can be checked by comparing the displayed LPG temperature and the LPG density against traceable measurements.

Note that the displayed LPG density is at 15°C ; therefore ensure that the instrument displays correct temperature of LPG before adjusting the density measurement.

10/1/19
6 May 2004

FIGURE 10/1/19 – 1

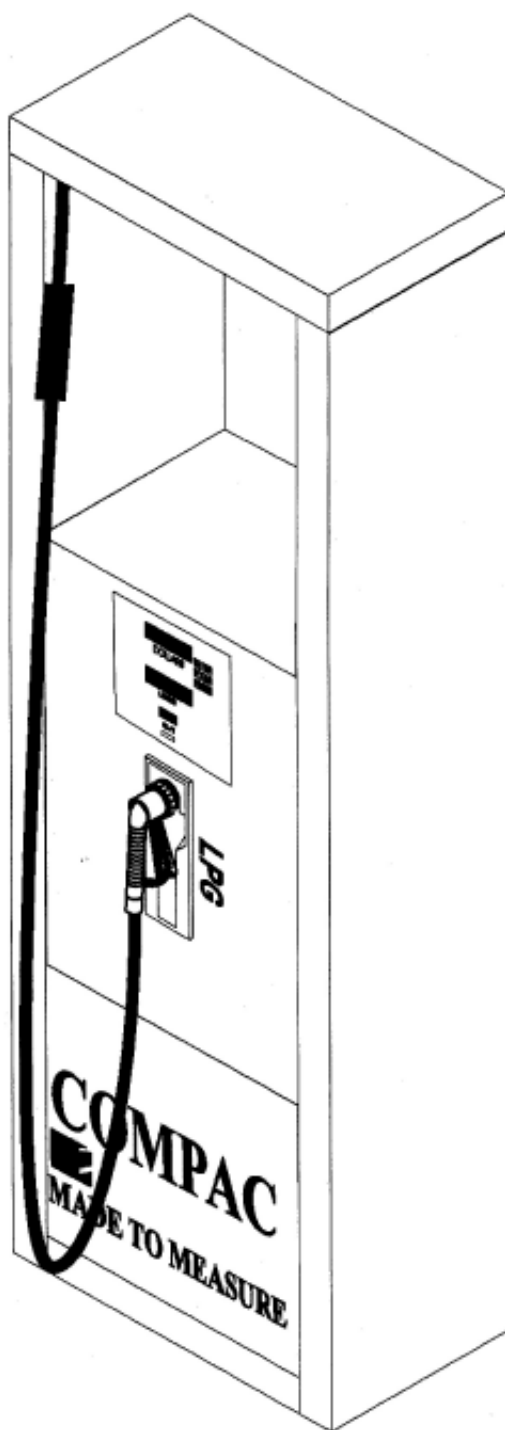

Compac Model Legend MD2LPG LPG Fuel Dispenser for Motor Vehicles

10/1/19
6 May 2004

FIGURE 10/1/19 – 2

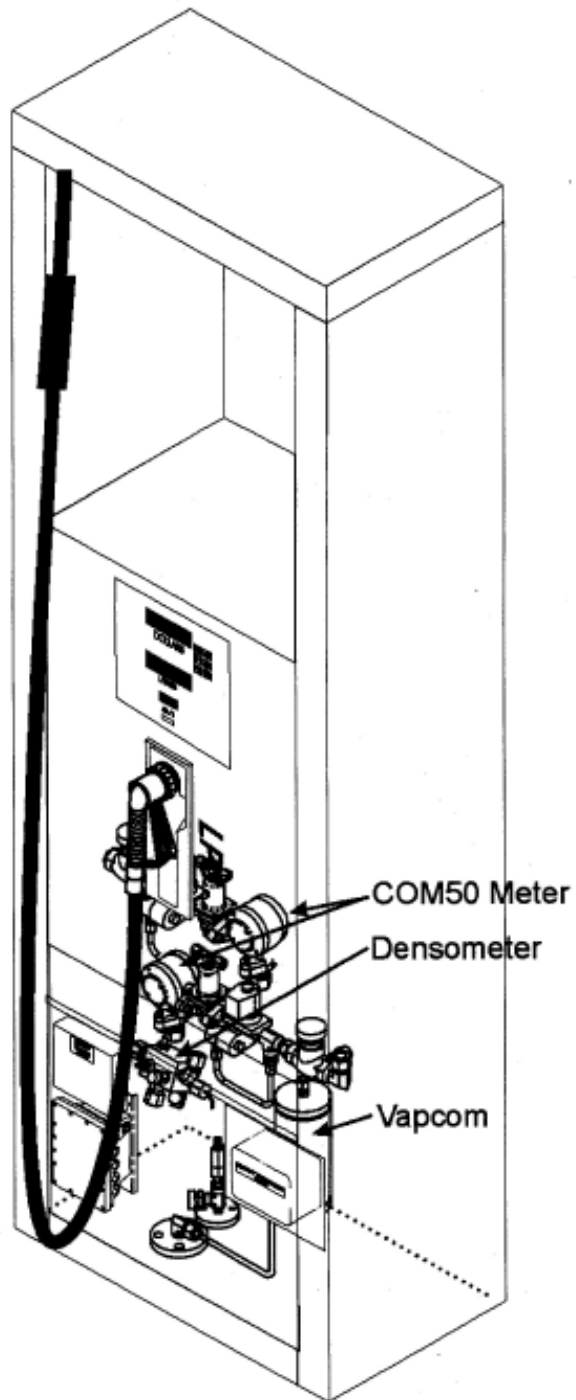

Compac Model Legend MD2LPG LPG Fuel Dispenser for Motor Vehicles

FIGURE 10/1/19 – 3

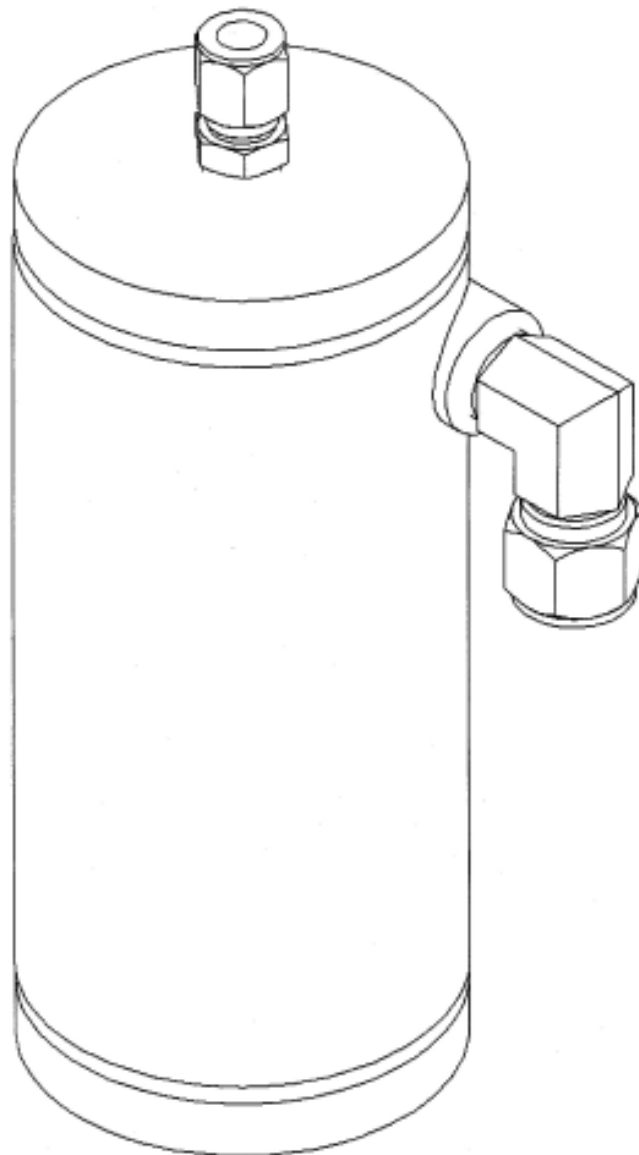

Compac Model VAPCOM Vapour Eliminator/Filter

10/1/19
6 May 2004

FIGURE 10/1/19 – 4

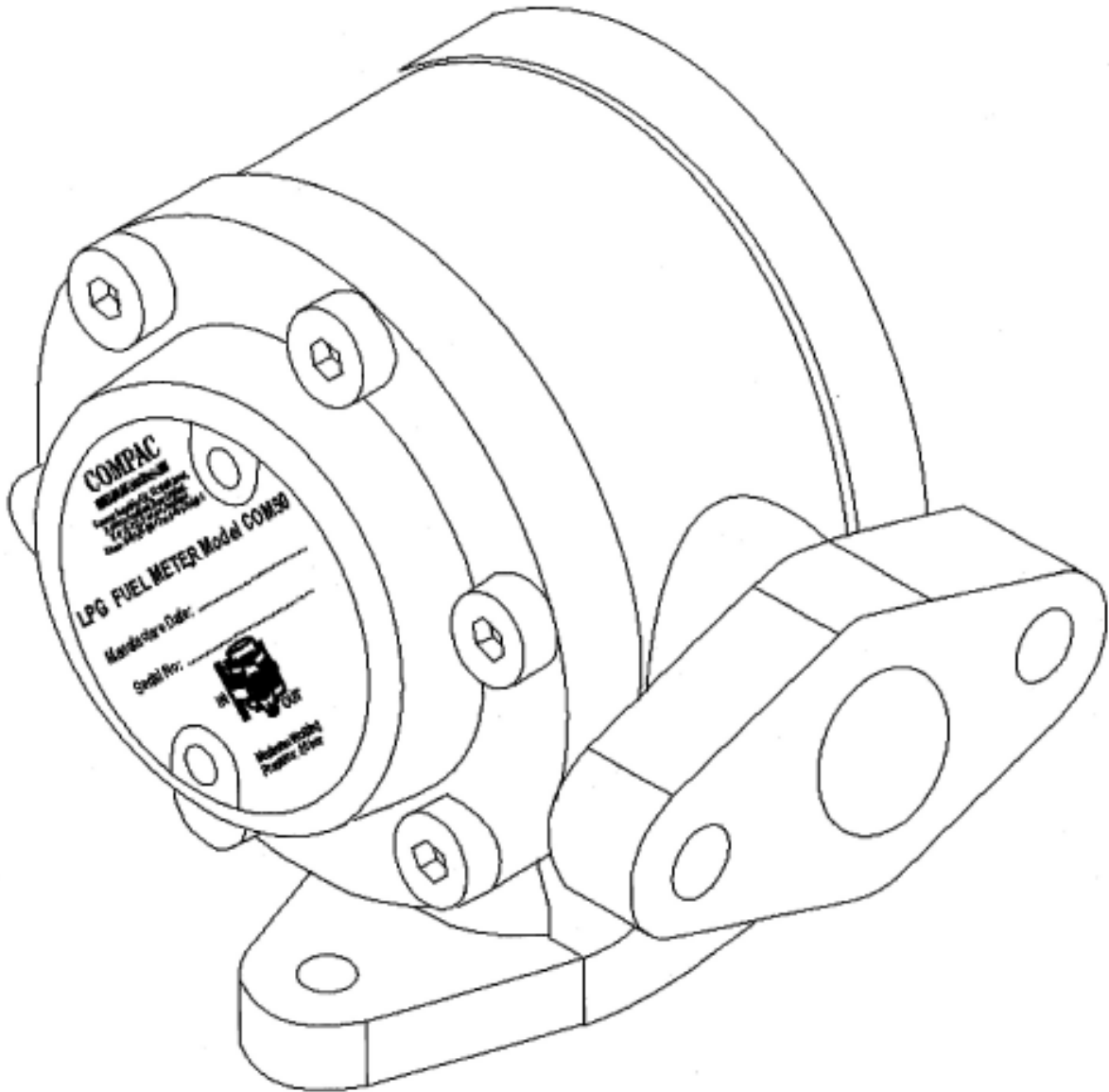

Compac Model COM50-LPG Flowmeter

FIGURE 10/1/19 – 5

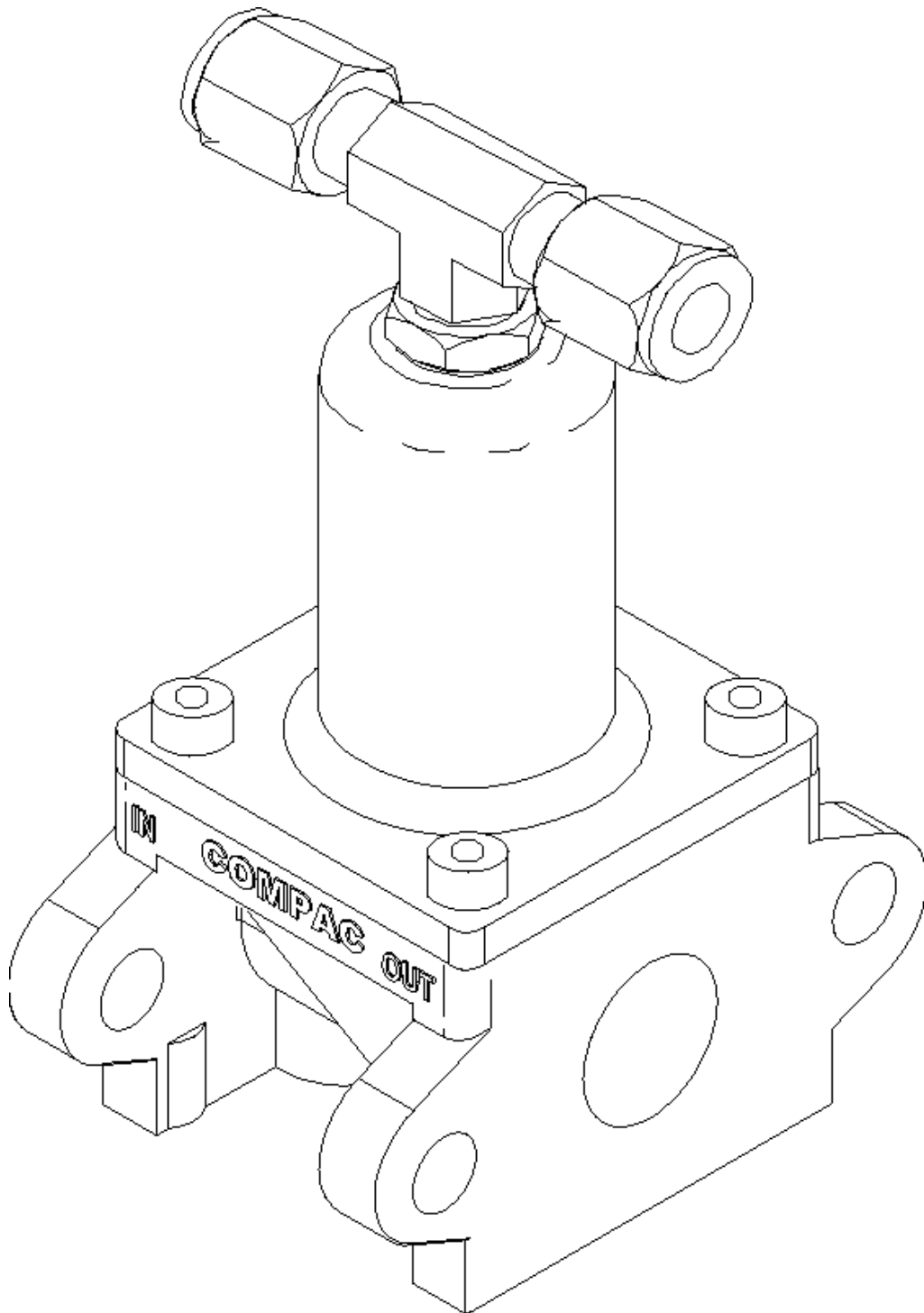

Compac Model DIFFVALVE Differential Valve

10/1/19
6 May 2004

FIGURE 10/1/19 – 6



Compac Model C4000 Calculator/Indicator

10/1/19
6 May 2004

FIGURE 10/1/19 – 7



Go-Gas Model Sealmaster Nozzle and Holster

10/1/19
6 May 2004

FIGURE 10/1/19 – 8

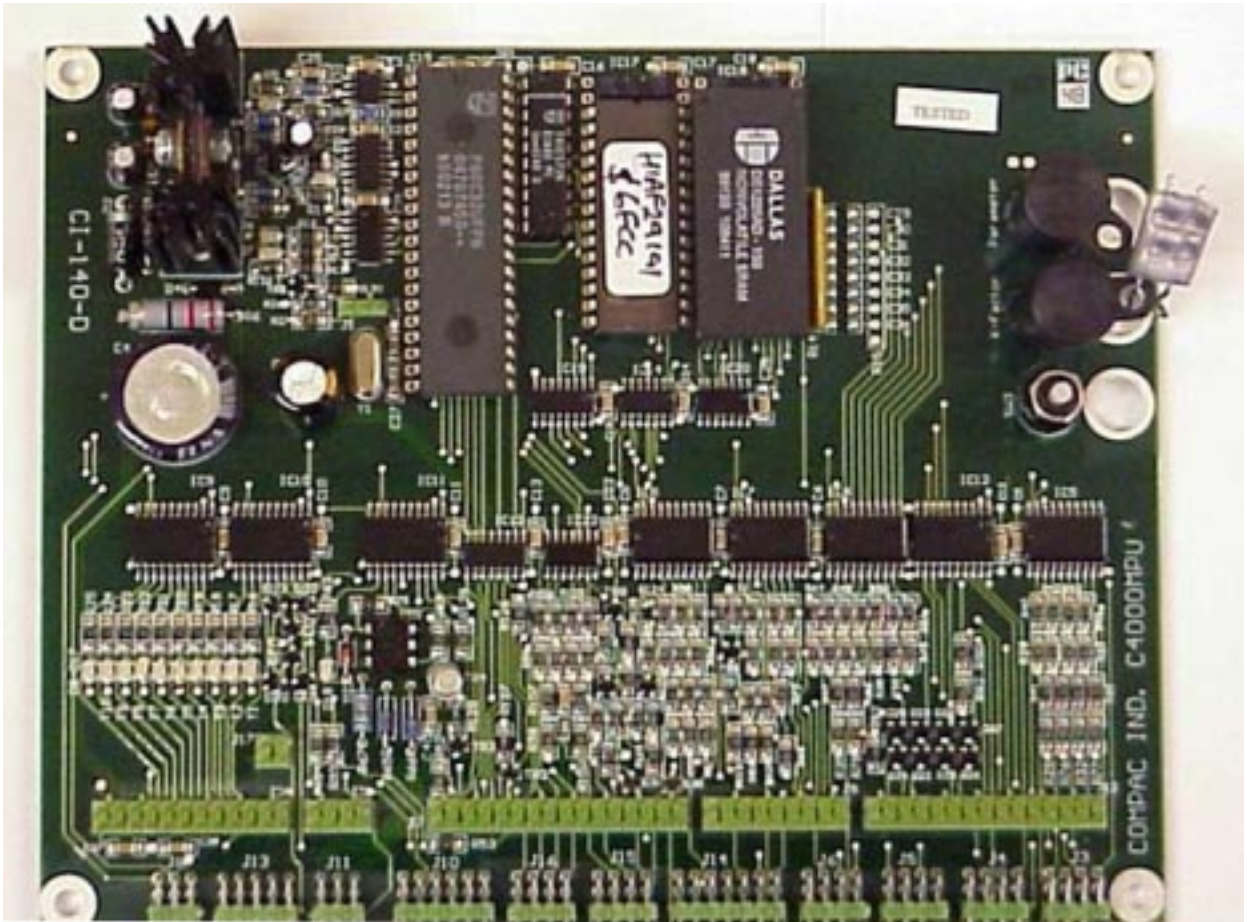

Sealing of Meter Calibration (K-factor) Switch

10/1/19
6 May 2004

FIGURE 10/1/19 – 9

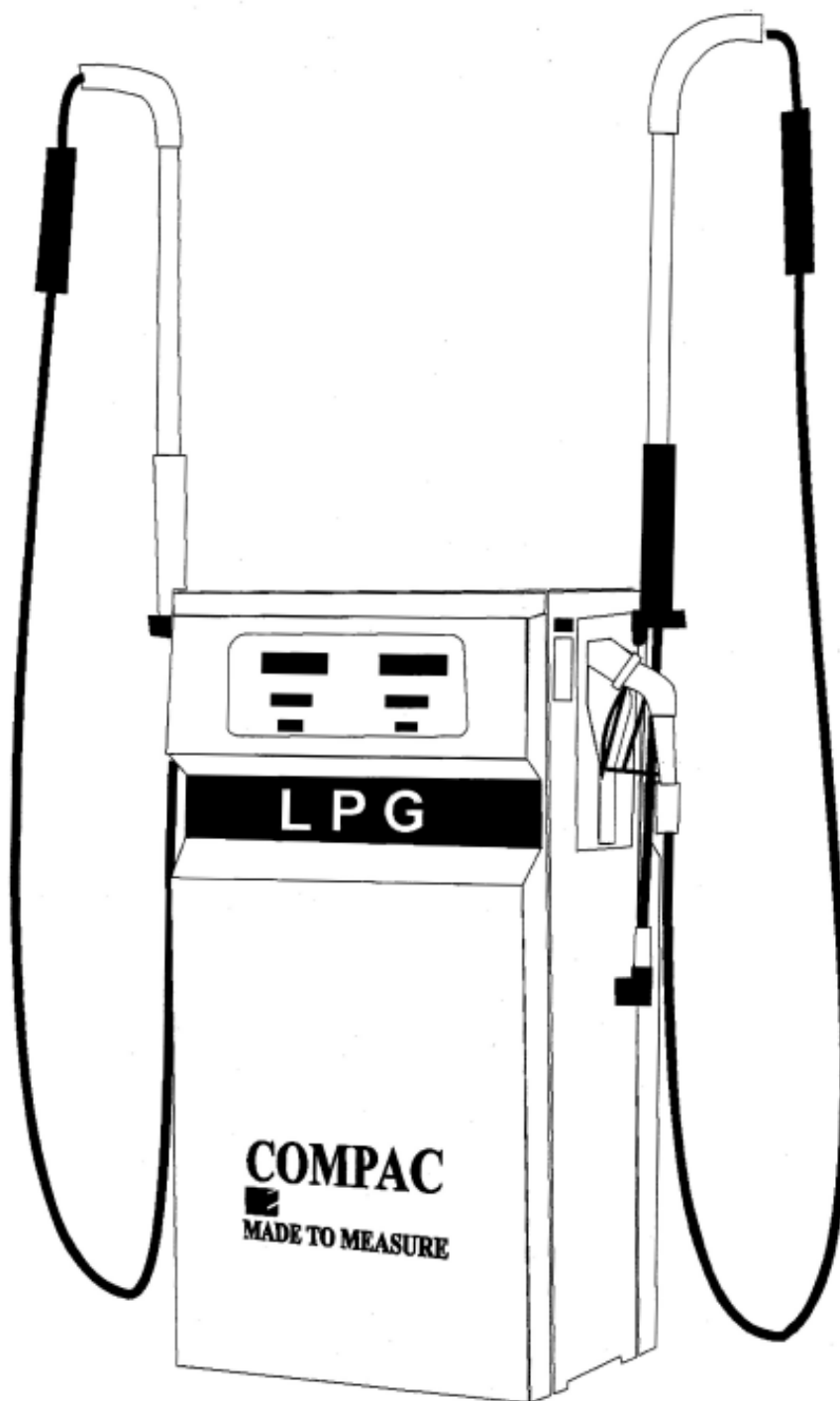

Compac Model Premier PR-LPG-D LPG Fuel Dispenser for Motor Vehicles

10/1/19
6 May 2004

FIGURE 10/1/19 – 10

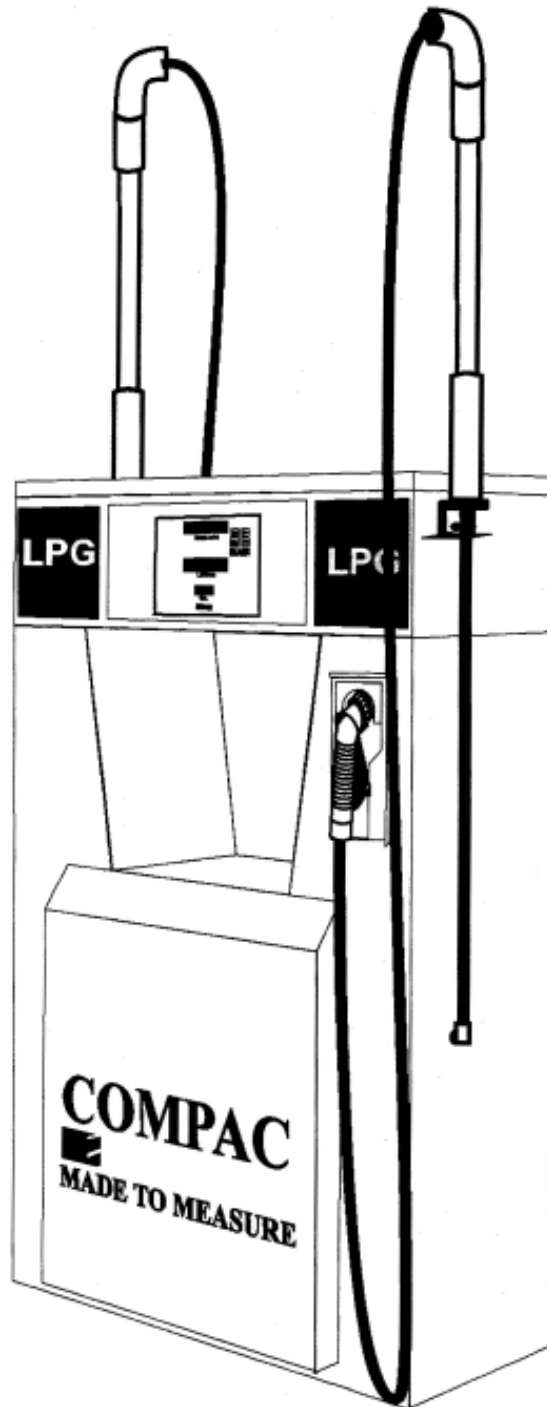

Compac Model Laser L-LPG-D LPG Fuel Dispenser for Motor Vehicles