



Australian Government

Department of Industry,
Science and Resources

**National
Measurement
Institute**

36 Bradfield Road, West Lindfield NSW 2070

Supplementary Certificate of Approval

NMI S838

Issued by the Chief Metrologist under Regulation 60
of the
National Measurement Regulations 1999

This is to certify that an approval for use for trade has been granted in respect of the instruments herein described.

Dini Argeo Model CPA2000 Load Cell

submitted by Dini Argeo S.r.l.
Via della Fisica 20
41042 Spezzano di Fiorano
Modena
Italy

NOTE: This Certificate relates to the suitability of the pattern of the instrument for use for trade only in respect of its metrological characteristics. This Certificate does not constitute or imply any guarantee of compliance by the manufacturer or any other person with any requirements regarding safety.

This approval has been granted with reference to document NMI R 60, *Metrological Regulation for Load Cells*, dated July 2004.

This approval is subject to review at the decision of the Chief Metrologist in accordance with the conditions specified in the document NMI P 106.

DOCUMENT HISTORY

Rev	Reason/Details	Date
0	Pattern and variant 1 approved – certificate issued	24/03/23

CONDITIONS OF APPROVAL

General

Instruments purporting to comply with this approval shall be marked with approval number 'NMI S838' and only by persons authorised by the submitter.

Instruments incorporating a component purporting to comply with this approval shall be marked 'NMI S838' in addition to the approval number of the instrument, and only by persons authorised by the submitter.

It is the submitter's responsibility to ensure that all instruments marked with this approval number are constructed as described in the documentation lodged with the National Measurement Institute (NMI) and with the relevant Certificate of Approval and Technical Schedule. Failure to comply with this Condition may attract penalties under Section 19B of the National Measurement Act and may result in cancellation or withdrawal of the approval, in accordance with document NMI P 106.

The values of the performance criteria (maximum number of scale intervals etc.) applicable to an instrument incorporating the pattern approved herein shall be within the limits specified herein and in any approval documentation for the other components.

Signed by a person authorised by the Chief Metrologist to exercise their powers under Regulation 60 of the *National Measurement Regulations 1999*.



Darryl Hines
Manager
Policy and Regulatory Services

TECHNICAL SCHEDULE No S838

1. Description of Pattern **approved on 24/03/23**

A Dini Argeo model CPA2000 stainless steel compression load cell of 2000 kg maximum capacity (Figure 1 and Table 1) and approved for use with up to 3000 verification scale intervals.

1.1 Method of Mounting

Mounting is to be in accordance with the manufacturer's instructions and as shown in Figure 2.

1.2 Markings

Each load cell is marked with the following:

Manufacturer's mark, or name written in full	Dini Argeo S.r.l.
Model number
Maximum capacity, E_{max} kg (or t)
Serial number
Pattern approval mark	NMI S838

1.3 Table of Specifications

Specifications for the pattern are given in Table 1.

2. Description of Variant 1 **approved on 24/03/23**

Certain other capacities and characteristics of the Dini Argeo model CPA series as listed in Table 1.

TABLE 1

Model Number	CPA2000	CPA3000	CPA5000	CPA7000	CPA10000
E_{max} (kg)	2000	3000	5000	7000	10 000
E_{min} (kg)	0	0	0	0	0
Class	C	C	C	C	C
nLC	3000	3000	3000	3000	3000
V_{min} (kg)	0.2	0.3	0.5	0.7	1
DR (kg)	0.333	0.5	0.833	1.167	1.667
mV/V	2	2	2	2	2
Input imp. (Ω)	1100	1100	1100	1100	1100
Voltage (V)	15	15	15	15	15
Cable length (m)	10.1	10.1	10.1	10.1	10.1
Number of leads (plus shield)	6	6	6	6	6

Where:

E_{max}	=	Maximum capacity
E_{min}	=	Minimum dead load
nLC	=	Maximum number of verification intervals
V_{min}	=	Minimum value of verification interval
DR	=	Minimum dead load output return value
mV/V	=	Output rating (nominal)
Input imp.	=	Input impedance (nominal)
Voltage	=	Maximum supply voltage (AC/DC)

FIGURE S838 – 1



Dini Argeo Model CPA Load Cell

FIGURE S838 – 2

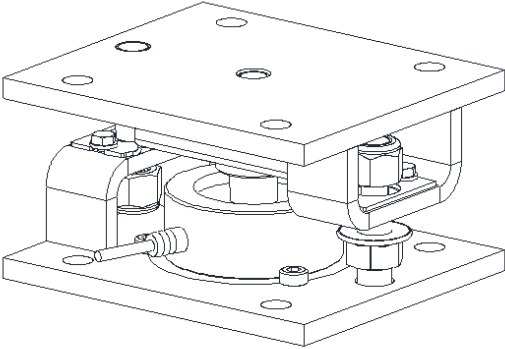

Typical Mounting Arrangement

~ End of Document ~