



Australian Government
Department of Industry,
Science and Resources

**National
Measurement
Institute**

36 Bradfield Road, West Lindfield NSW 2070

Certificate of Approval
NMI 5/6E/25

Issued by the Chief Metrologist under Regulation 60
of the
National Measurement Regulations 1999

This is to certify that an approval for use for trade has been granted in respect of the instruments herein described.

Innovative Tap Solutions model PourMyBeer self-serve beer flowmetering system

submitted by Pourmybeer Australia Pty Ltd
391 King Street
Newtown NSW 2042

NOTE: This Certificate relates to the suitability of the pattern of the instrument for use for trade only in respect of its metrological characteristics. This Certificate does not constitute or imply any guarantee of compliance by the manufacturer or any other person with any requirements regarding safety.

This approval has been granted with reference to document NMI R 117 *Measuring Systems for Liquids Other than Water*, dated June 2011.

This approval is subject to review at the decision of the Chief Metrologist in accordance with the conditions specified in the document NMI P 106.

DOCUMENT HISTORY

Rev	Reason/Details	Date
0	Pattern provisionally approved – interim certificate issued	27/09/22
1	Pattern amended (Test procedure) – Pattern & Variant 1 approved – certificate issued	05/12/23

CONDITIONS OF APPROVAL

General

Instruments purporting to comply with this approval shall be marked with approval number 'NMI 5/6E/25' and only by persons authorised by the submitter.

Instruments purporting to comply with this approval and currently marked 'NMI P5/6E/25' may be re-marked 'NMI 5/6E/25' but only by persons authorised by the submitter.

It is the submitter's responsibility to ensure that all instruments marked with this approval number are constructed as described in the documentation lodged with the National Measurement Institute (NMI) and with the relevant Certificate of Approval and Technical Schedule. Failure to comply with this Condition may attract penalties under Section 19B of the National Measurement Act and may result in cancellation or withdrawal of the approval, in accordance with document NMI P 106.

Signed by a person authorised by the Chief Metrologist to exercise their powers under Regulation 60 of the *National Measurement Regulations 1999*.



Darryl Hines
Manager
Policy and Regulatory Services

TECHNICAL SCHEDULE No 5/6E/25

1. Description of Pattern **provisionally approved on 27/09/22**
approved on 05/12/23

An Innovative Tap Solutions model PourMyBeer self-serve beer flowmetering system using a Titan Beverage Meter model 300-010 positive-displacement flowmeter approved for delivering beer in measured quantities from 50 mL to 1000 mL

1.1 Field of Operation

The field of operation of the measuring system is determined by the following characteristics:

• Minimum measured quantity (V_{min})	50 mL
• Maximum delivery	1 000 mL
• Maximum flow rate (Q_{max})	10 000 mL/min
• Minimum flow rate (Q_{min})	500 mL/min
• Maximum pressure of the liquid (P_{max})	1000 kPa
• Ambient temperature range	-10 °C to 40 °C
• Liquid temperature range	0 °C to 35 °C
• Accuracy class	0.5
• Product	beer, cider, wine

The flowmeter is adjusted to be correct for the liquid for which it is to be verified and as marked on the data plate.

Liquid is supplied to the system by means of a pressurised bulk container (keg).

1.2 The System

The PourMyBeer self-serve beer flowmetering system (Figure 1) authorises deliveries a pre-programmed radiofrequency (RFID) card. The delivery is initiated by pulling the operating lever forward; the desired amount is poured (into supplied glassware) until the lever is released stopping the delivery. The quantity delivered is displayed on the screen.

The system comprises the following components:

(i) Check In terminal

A PC-based device is used to program the RFID card used by the customer. RFID cards are programmed to operate in either pre-paid mode where the system will stop delivery of beer once the pre-paid amount has been reached, or in a post payment where customers must finalise payment after delivery.

(ii) Self-serve terminal

A delivery is initiated by placing the customers RFID card on the self-serve terminal (Figure 2) and pressing the touch screen display to begin the delivery. The beer is poured (into supplied glassware) until the customer stops pressing the display.

The self-serve terminal contains an LCD touch screen display and RFID card reader. The self-serve terminal controls the flow of beer with the solenoid nozzle and receives the measuring signal from the measurement transducer.

The unit price, measured quantity and price for the beer delivered is displayed on the screen.

The self-serve terminal operates software version 1.nn.xx.zz where

- 1 is the version number relating to the part containing the legally relevant “metrological” functionality,
- nn is the Release version to identify which version is installed at the customers premises,
- xx relates to “major” non-metrological changes,
- zz relates to “minor” non-metrological changes.

The software version is displayed by selecting “device status” from the administration menu which is accessible using an administrator RFID card.

(iii) Measurement Transducer

The system uses a Titan Beverage Meter model 300-010 positive-displacement flowmeter approved for delivering beverages.

(iv) Solenoid Nozzle

An electromechanically operated solenoid valve is built into the dispensing nozzle (Figure 3) and controls the delivery of the liquid.

(v) Foam on Beer (FOB) detector

Each dispense tap is connected to a Foam on Beer (FOB) detector and if required an electrical pump. These are located as close to the keg as possible.

(v) Check valve and In line flow restrictor

The system may include an optional check valve and/or an in-line flow restriction device (Figure 4) to fine-tune the speed of the flow prior to, or during, on-site verification for the user to be able to pour a consistent beverage and will be related to the specific product configured at set-up. The in-line flow restriction device is secured at completion of the verification such that it cannot be accessed by the user without damaging/breaking the sealing/securing (see **section 1.6**). There are no additional flow control devices present or accessible to the user.

(v) Uninterruptible Power Supply

An uninterruptible power supply (UPS) is used that is capable of maintaining power for sufficient time to complete a transaction in the event of a power failure.

1.3 Checking facility

The self-serve terminal monitors the presence and correct transmission of signal from the measurement transducer, and in the event of detecting a fault the instrument and has provision for controlling electrically operated valves to stop the delivery.

In the event of a power failure, the indication is maintained by the uninterruptible power supply (UPS).

The checking facilities will prevent the system from initiating measurement where the following conditions are detected:

- gas pressure has deviated away from a pre-set threshold by more than 10% upon completion of the preceding delivery.
- FOB detector has detected that the keg is empty.
- RFID card not seated, or incorrectly seated on reader.
- FOB detector not connected to the self-serve terminal.
- safety shut-off has been activated, i.e. solenoid valve overheat protection, electric pump overheat protection.

- LCD is powered off.
- Software has been shutdown.

The checking facilities will prevent further use of the system and error messages will be displayed on the LCD touch screen display.

1.4 Tap Compensation

A 'tap compensation' value is used to facilitate erroneous pours due to tap handle activation while no user card is present. Pulling the tap handle without a card can disrupt the pressure balance in the line between the tap and the solenoid valve causing some liquid to exit from the tap. This compensation value is designed to permit the initial flow of beverage through the meter when the valve has been opened after the handle has been opened without a card present. This value is determined by the installation engineer during initial system set up.

1.5 Verification Provision

Provision is made for the application of a verification mark.

1.6 Sealing Provision

Securing and sealing may be by using security wire and seal, by a security sticker, or shrink wrap tubing, which shall bear uniquely identifiable markings; the security sticker shall also be "void" or destroyed when removed.

A solenoid valve and meter will be installed in a secure housing (see figure 5) with a visible security seal placed over the screws and/or the joint of the housing preventing access without breaking the seal. Where the valve and meter are not installed in a secure housing, owing to on site restrictions, the meter and valve will each have a security seal attached at their connections to the beer line (see Figure 5) preventing their removal without breaking the seal. Alternatively, a continuous wire wrap, terminating with a security seal, starting from the tap connection to the end of the solenoid valve connector may be used.

Where a check valve or adjustable flow restrictor is fitted this must have a security sticker or shrink wrap with suitable security seal placed across the device to ensure no further adjustments are possible, following verification, without breaking the seal.

Provision is made for the parameters of the Self-serve terminal to be sealed by the system electronically using a secure RFID card used to access configurable parameters of the instrument.

The system records the interventions to the configurable parameters in an audit trail. The date of most recent intervention can be compared to the date of the previous verification.

1.7 Descriptive Markings and Notices

Instruments are marked with the following data, together in one location, in the form shown at right:

Manufacturer's mark, or name written in full
Name or mark of manufacturer's agent
Pattern approval number	NMI P5/6E/25
Minimum delivery	50 mL
Maximum delivery	1 000 mL
Environmental class	-10 °C to +55 °C
Year of Manufacture
Serial number of the instrument

- (#1) In addition, the minimum measured quantity (V_{min}) shall be clearly visible on any indicating device visible to the user during measurement, in the form 'Minimum delivery 50 mL' or 'Minimum delivery 0.050 L'.

2. Description of Variant 1

approved on 05/12/23

An Innovative Tap Solutions model PourMyBeer self-serve beer flowmetering system using a Flownetix model 100 series ultrasonic flowmeter (Figure 6).

The variant has the same characteristics as the pattern with the exception that there is no maximum delivery.

Instruments do not require a marking of Maximum delivery.

TEST PROCEDURE 5/6E/25

Instruments shall be tested in accordance with any relevant tests specified in the National Instrument Test Procedures.

Maximum Permissible Errors

The maximum permissible errors are specified as:

$$\begin{aligned} \text{For deliveries } \geq 50 \text{ mL and } \leq 400 \text{ mL} &= \pm 4 \text{ mL} \\ \text{For deliveries } > 400 \text{ mL and } \leq 1\,000 \text{ mL} &= \pm 1 \% \end{aligned}$$

TESTS

1. Visually inspect the instrument dispenser and ensure it complies with the certificate of approval.
2. Use appropriate reference standards of measurement meeting the requirements of Section 10 of the *National Measurement Act 1960* which can be used to determine the quantity of the liquid being measured to an uncertainty of at least three times better than the MPE for the flowmetering system.
3. The flowmetering system shall measure within the specified MPE across the approved field of operation for the flowmetering system. The system error shall be calculated using the formulae:

$$E_{FS} = (V_{FS} - V_{REF}) / V_{REF} \times 100.$$

E_{FS} relative error

V_{FS} volume indicated by flowmetering system.

V_{REF} reference volume

4. Accuracy testing shall be completed for the following:
 - a. One delivery at the minimum measured quantity.
 - b. One delivery at five times the minimum measured quantity.
 - c. Three deliveries at ten times the minimum measured quantity.
 - d. One delivery at twenty times the minimum measured quantity.
 - e. One delivery at five times the minimum measured quantity interrupting the flow five times.
 - f. Verify operation of checking facilities as described in **section 1.3** when the product level is low.

This test is only required at initial verification or when changes affecting the low level cut off are made and only once for instruments which share a product supply.

It is advisable to use the product intended to be measured.

If testing with beer, let the volumetric measure stand for 2 minutes, or a beer anti-foaming agent may be used.

Note: This test may alternatively be conducted using a pressurised system dispensing water as a test medium.

5. Where Test 4 is conducted using water as the test medium, after the system is configured for the product intended to be measured the following accuracy testing shall be completed:
 - a. One delivery at the minimum measured quantity.
 - b. One delivery at ten times the minimum measured quantity.
6. Correct transmission of price and quantity to the check in terminal
7. Verify operation of tap compensation as described in **section 1.4**

FIGURE 5/6E/25 – 1

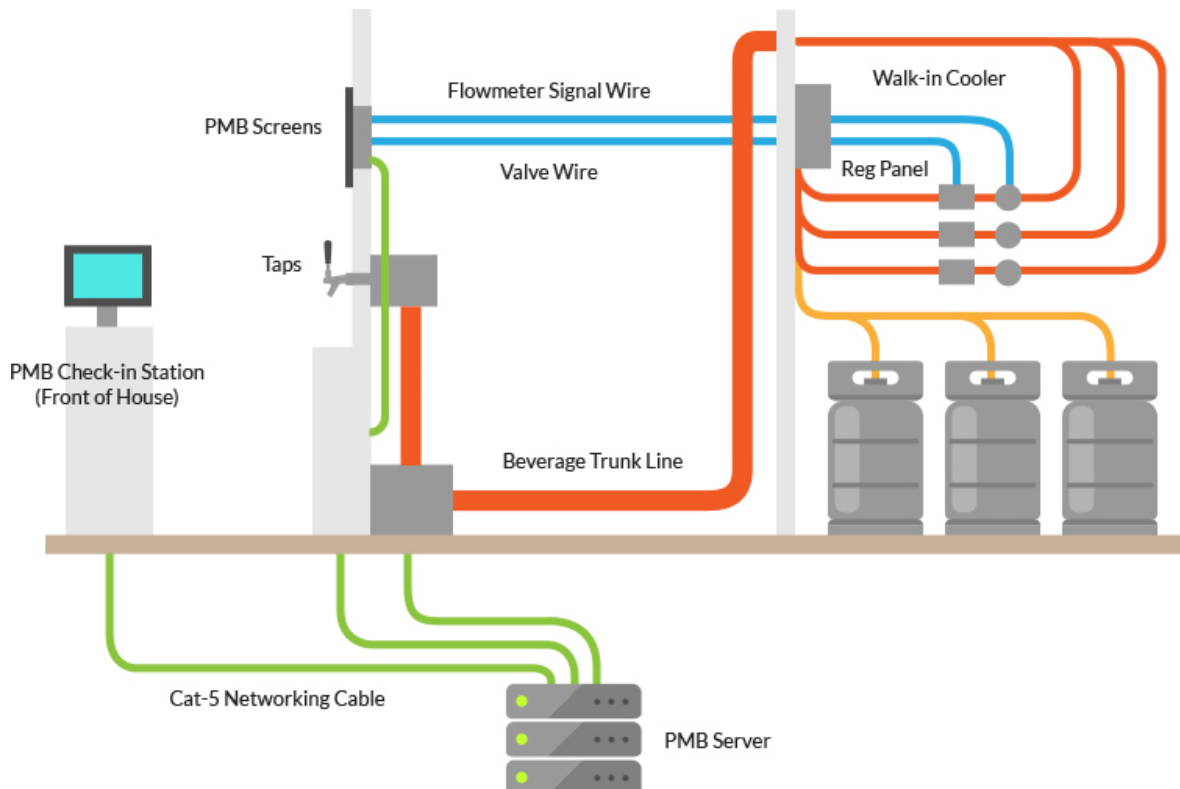
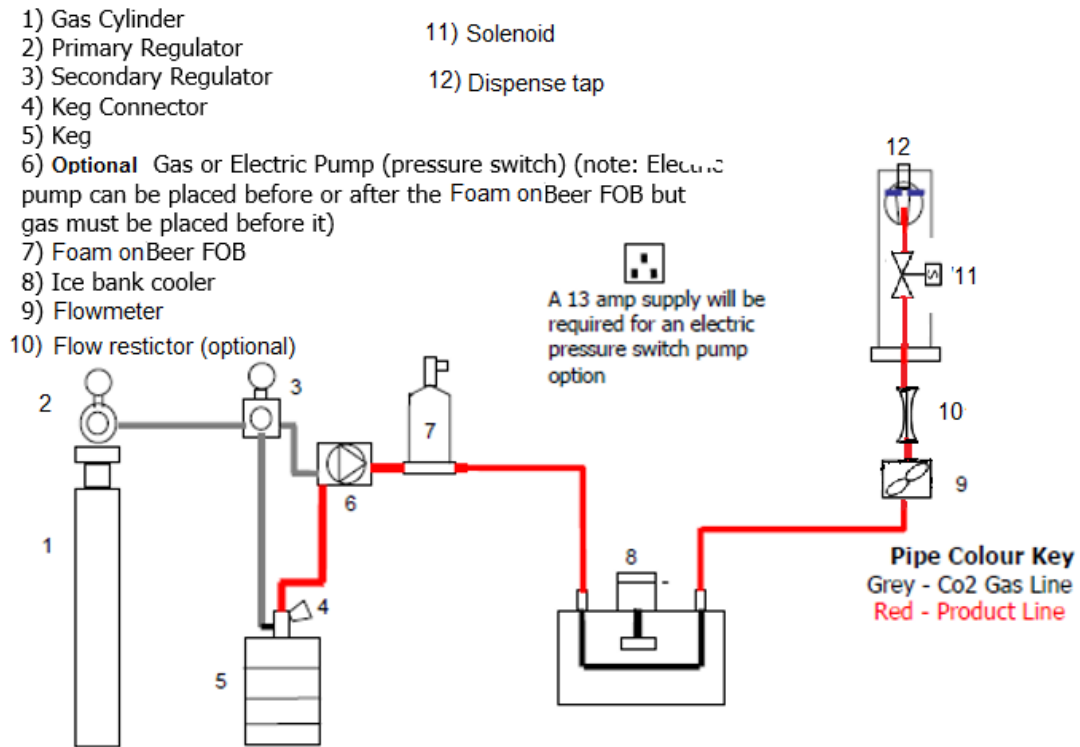

Innovative Tap Solutions Model PourMyBeer Beer Flowmetering System

FIGURE 5/6E/25 – 2

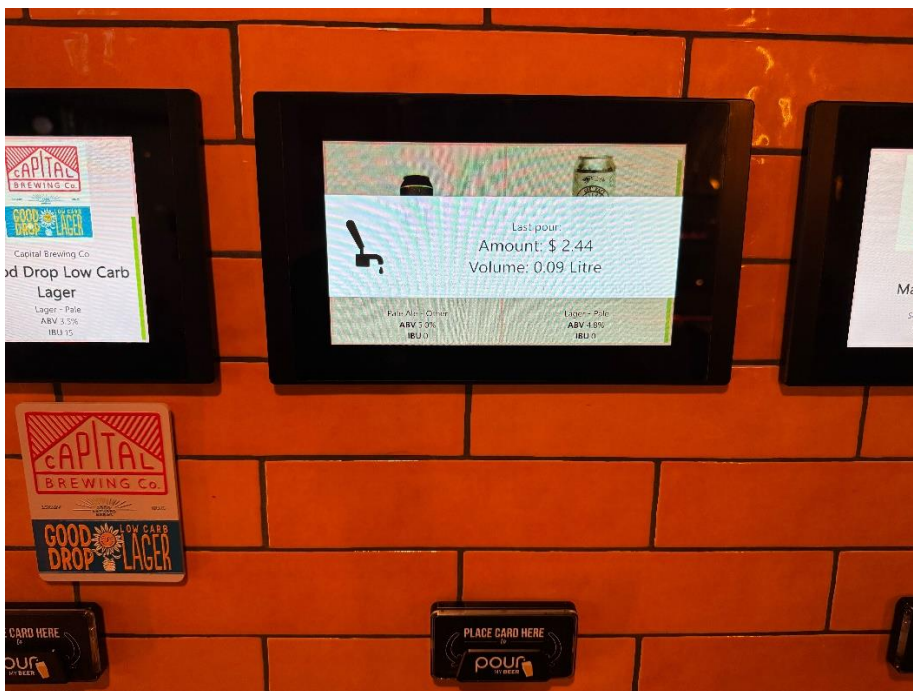
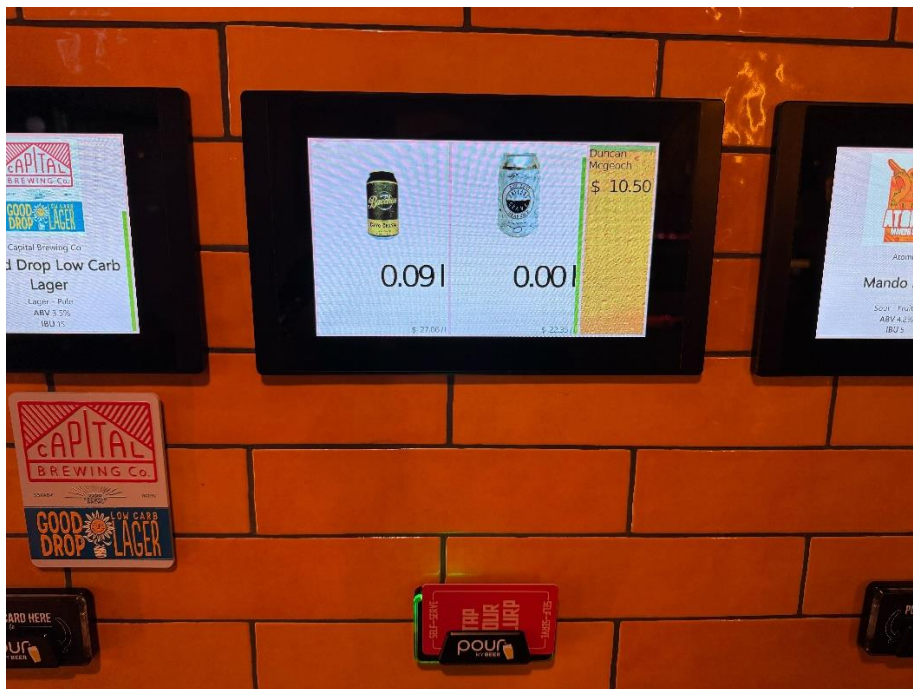

PourMyBeer self-serve terminal

FIGURE 5/6E/25 – 3



Solenoid Valve

FIGURE 5/6E/25 – 4

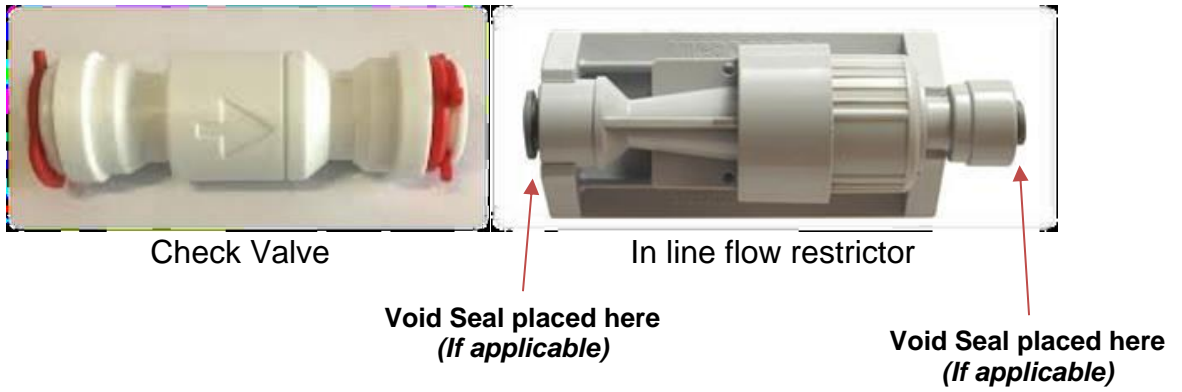
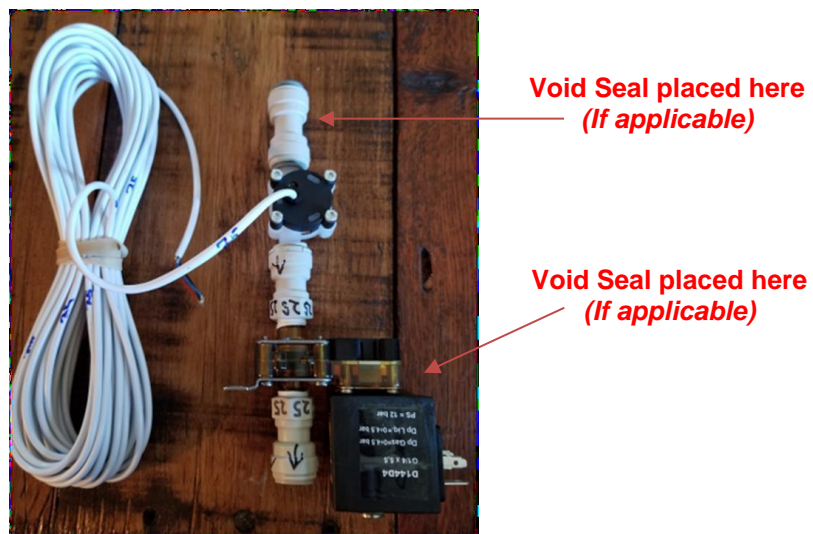
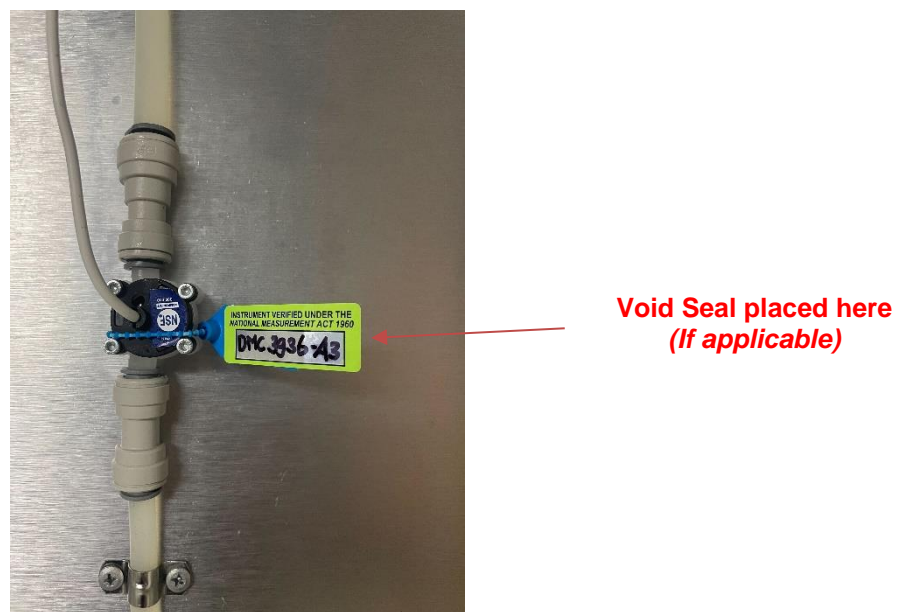

FIGURE 5/6E/25 – 5



Valve and meter without secure housing

FIGURE 5/6E/25 – 6



Flownetix model 100series ultrasonic flowmeter (Variant 1)

~ End of Document ~