



Australian Government  
Department of Industry,  
Innovation and Science

## National Measurement Institute

36 Bradfield Road, West Lindfield NSW 2070

### Certificate of Approval NMI 5/6A/229

Issued by the Chief Metrologist under Regulation 60  
of the  
*National Measurement Regulations 1999*

This is to certify that an approval for use for trade has been granted in respect of the instruments herein described.

Gallagher Model Pulse CX8P Fuel Dispenser for Motor Vehicles

submitted by Gallagher Fuel Systems Ltd  
2 Station Road  
Marton 4741 New Zealand

**NOTE:** This Certificate relates to the suitability of the pattern of the instrument for use for trade only in respect of its metrological characteristics. This Certificate does not constitute or imply any guarantee of compliance by the manufacturer or any other person with any requirements regarding safety.

This approval has been granted with reference to document NMI R 117 Measuring Systems for Liquids Other than Water, dated June 2011.

This approval becomes subject to review on 1/08/23, and then every 5 years thereafter.

#### DOCUMENT HISTORY

Rev	Reason/Details	Date
0	Pattern & variants 1 to 4 approved – interim certificate issued	15/02/13
1	Pattern amended (validity date) – interim certificate issued	27/05/13
2	Pattern & variants 1 to 4 approved – certificate issued	26/06/13
3	Variant 5 approved – certificate issued	27/09/13
4	Variant 6 approved – certificate issued	6/12/13
5	Variant 7 approved – certificate issued	26/02/14
6	Variant 8 provisionally approved – interim certificate issued	7/06/16

Document History (cont...)

Rev	Reason/Details	Date
7	Pattern and Variants 1 to 8 reviewed – Variant 1 amended (Table 1 - ultra large base model added) – certificate issued	16/07/18
8	Variant 9 approved – certificate issued	19/04/24

CONDITIONS OF APPROVAL

**General**

Instruments purporting to comply with this approval shall be marked with pattern approval number 'NMI 5/6A/229' and only by persons authorised by the submittor.

It is the submittor's responsibility to ensure that all instruments marked with this approval number are constructed as described in the documentation lodged with the National Measurement Institute (NMI) and with the relevant Certificate of Approval and Technical Schedule. Failure to comply with this Condition may attract penalties under Section 19B of the National Measurement Act and may result in cancellation or withdrawal of the approval, in accordance with document NMI P 106.

Auxiliary devices used with this instrument shall comply with the requirements of General Supplementary Certificate No S1/0B.

**Special Conditions of Approval: (Provisional Approval – Variant 8)**

This approval is limited to five (5) sites only, the locations of which may be obtained from the National Measurement Institute. The submittor shall advise NMI in writing of the proposed location or serial number of each instrument prior to it being initially verified.

Instruments purporting to comply with this approval shall be marked with approval number 'NMI P5/6A/229' and only by persons authorised by the submittor. (Note: The 'P' in the approval number may be a temporary marking.)

The approval will remain provisional pending completion of satisfactory testing and evaluation.

The submittor shall provide NMI with copies of test results from the initial verification and all subsequent tests.

In the event of unsatisfactory performance the approval may be cancelled (or altered).

The submittor shall implement such modifications as required by NMI. In the event that such modifications (if any are required by NMI) are not made to the satisfaction of NMI, this approval may be withdrawn.

Signed by a person authorised by the Chief Metrologist to exercise their powers under Regulation 60 of the *National Measurement Regulations 1999*.

**Darryl Hines**  
Manager  
Policy and Regulatory Services

TECHNICAL SCHEDULE No 5/6A/229

**1. Description of Pattern** **approved on 15/02/13**

A Gallagher model Pulse CX8P fuel dispenser for motor vehicles approved to dispense distillate or various grades of fuels (\*), in attendant-operated mode, or in attended self-service mode using any compatible (#) approved control console. The meter is adjusted to be correct for the liquid for which it is to be verified.

- (\*) Including up to 85% ethanol (E10) and various grades of pure biodiesel and biodiesel/distillate blends (to Australian government standard).
- (#) 'Compatible' is defined to mean that no additions/changes to the hardware/software specified in this approval are required for satisfactory operation of the complete system.

**1.1 Field of Operation**

The field of operation of the measuring system is determined by the following characteristics:

- Minimum measured quantity,  $V_{min}$  2 L
- Maximum flow rate,  $Q_{max}$  80 L/min
- Minimum flow rate,  $Q_{min}$  5 L/min
- Maximum pressure of the liquid,  $P_{max}$  350 kPa
- Minimum pressure of the liquid,  $P_{min}$  100 kPa (#1)
- Range of liquids viscosity 0.5 to 20 mPa.s (at 20°C) (#2)
- Maximum temperature of the liquid,  $T_{max}$  50°C
- Minimum temperature of the liquid,  $T_{min}$  -10°C
- Ambient temperature range -10 to 55°C
- Accuracy class 0.5

(#1) Minimum pressure required for effective operation of the gas elimination device.

(#2) The flowmeter is adjusted for use with one product viscosity. Fuels include kerosene, distillate and various grades of petrol (which may include up to 85% ethanol). The pattern and variants constructed for use to dispense various grades of pure biodiesel and biodiesel/distillate blends (to Australian government standard).

**1.2 Description of the Metering System**

The Gallagher model Pulse CX8P fuel dispenser (Figure 1) incorporates the following components and features:

- (i) The supply line for each grade of fuel is connected to a Tatsuno model FP1001 pump/strainer/gas separator (Figure 2). A gas/air test valve is provided for checking the operation of the gas elimination device.
- (ii) The supply is measured using one or two Tatsuno model MP-02515 4-piston positive displacement meters (eight in total), one for each nozzle (Figures 1, 3 and 4). Each meter is fitted with a PEC model #07434 pulse generator that communicates the volume of fluid measured to the indicators.
- (iii) Two Production Engineering model MHP price-computing calculator/indicators or any other compatible (#) NMI-approved calculator/indicator.

(iv) Eight hoses/nozzles are mounted on the side of the dispenser housing. Each hose is fitted with a ZVA nozzle. (\*\*)

(\*\*) Note that the submitter must be consulted regarding the acceptability of any alternative nozzles.

Control to the flow of each nozzle is achieved with either one or more Asco model PAG 29221 or other compatible (#) single or two-stage solenoid valves or with Asco model PVXG291A111 or other compatible (#) proportional valves.

### 1.3 Calculator/Indicator

Two Production Engineering model MHP price-computing calculator/indicators or any other compatible (#) NMI-approved calculator/indicator (one either side of the dispenser, Figure 1) display the following for each grade of fuel:

Volume 000.00 L to 999.99 L in 0.01 L increments

Unit price 0.1 to 999.9 c/L in 0.1 c/L increments

Price \$000.00 to \$999.99 in 1 c increments

Totaliser (##) to 9999999 L

(#) 'Compatible' is defined to mean that no additions/changes to the hardware/software specified in this approval are required for satisfactory operation of the complete system.

(##) Electronic totaliser (software driven and resettable) and non-resettable mechanical totalisers (one for each grade of fuel).

Software version number P2.XX is used. This may be displayed as one of the manager's functions accessed using the 'diagnostic switch' and the 'service agent button' – refer to the operator's manual.

The fuel dispenser is fitted with a pre-set keypad facility that allows pre-set values to be entered. The pre-set amount is displayed on a separate display that is positioned above the keypad. The amount may be viewed before, during and after the delivery is complete.

### 1.4 Sealing Provision

The gas separator test valve has provision for sealing. The meter calibration has provision for sealing as shown in Figure 4.

### 1.5 Verification Provision

Provision is made for the application of a verification mark.

### 1.6 Checking Facilities

An automatic segment test is performed at the start of each delivery.

Removing the nozzle from its normal hang-up position initiates a segment check of the price, volume and unit price displays.

- Delivery is stopped if excessive amounts of air/vapour are detected.
- In the event of a power failure, the displayed value for a delivery is retained.
- Delivery is stopped and an error displayed if an error in pulse output is detected.

## 1.7 Descriptive Markings and Notices

Instruments are marked with the following data, together in one location on a data plate:

Pattern approval sign	NMI 5/6A/229	
Manufacturer's identification mark or trade mark	.....	
Manufacturer's designation (model number)	.....	
Serial number	.....	
Year of manufacture	.....	
Maximum flow rate ( $Q_{max}$ )	..... L/min	
Minimum flow rate ( $Q_{min}$ )	..... L/min	
Minimum measured quantity ( $V_{min}$ )	..... L	(#1)
Maximum operating pressure ( $P_{max}$ )	..... kPa	
Minimum operating pressure ( $P_{min}$ )	..... kPa	
Nature of liquids to be measured	.....	(#2)
Maximum temperature of the liquid, $T_{max}$	..... °C	(#3)
Minimum temperature of the liquid, $T_{min}$	..... °C	(#3)
Environmental class	class N	

(#1) In addition, the minimum measured quantity ( $V_{min}$ ) shall be clearly visible on any indicating device visible to the user during measurement, in the form 'Minimum delivery 2 L'.

(#2) e.g. 'petrol', 'distillate', 'P' or 'D'.

(#3) Required if liquid temperature range differs from -10°C to 50°C.

## 2. Description of Variant 1 approved on 15/02/13

Certain other models and configurations of the Pulse series of fuel dispensers (Figures 5 and 6) identified using Table 1 below.

## 3. Description of Variant 2 approved on 15/02/13

With two Tatsuno model FP1001 pump/strainer/gas separators working in parallel feeding a single Tatsuno model FM-1002-A21#001 Lobetype positive displacement meter (Figure 7) fitted with a Gallagher model #2A33866 pulse generator that communicates the volume of fluid measured to the indicator.

- Minimum measured quantity,  $V_{min}$  5 L
- Maximum flow rate,  $Q_{max}$  160 L/min
- Minimum flow rate,  $Q_{min}$  16 L/min

## 4. Description of Variant 3 approved on 15/02/13

With one or more compatible submersible turbine pumps (STPs) incorporating a leak detection system. The STP replaces the equivalent components (i.e. motor, pump/strainer/gas separator, and associated pipework) in certain fuel dispensers covered by this approval.

## 5. Description of Variant 4 approved on 15/02/13

Any Gallagher Pulse series fuel dispenser of this approval now fitted with a PEC model Vapour Recovery Stage 2 (aka VR11) vapour recovery and monitoring system and used up to a maximum flow rate of 45 L/min. A typical instrument and system are shown in Figures 3 and 8.

The VRII system controller continuously monitors the vacuum line pressure, taking inputs from a pressure switch or sensor whilst monitoring the correct operation of the vapour recovery system for hoses on each side of the fuel dispenser.

The site vacuum system uses vacuum pumps housed in their own enclosure. Integral vacuum systems use a Durr vacuum pump housed in the dispenser (Figures 3 and 8).

The vapour recovery and monitoring system is approved by the German TÜV SÜD Industrie Service GmbH authority.

Only vapour recovery components and systems as listed below and included in the relevant TÜV approval certificates may be used, namely:

(i) **For collection of vapour:**

- 85-2.169 NSW
- 85-2.175-1 NSW
- 85-2.175 NSW
- 85-2.176-1 NSW
- 85-2.176 NSW
- 85-2.23-2
- 85-2.57-3
- 85-2.67-3
- 85-2.79
- 85-2.93
- 85-2.XXX
- 85-9.10-1 NSW
- 85-9.10 NSW

and the only approved system components are:

- Vapour recovery nozzles – Elaflex SLIMLINE 2 GR, Husky, or OPW Avance and 12 VW (vapour suction inlet on high position)
- Coaxial hose – Elaflex model Conti Slimline or Goodyear Flexsteel vapour assist
- Control valves – Burkert model 2832
- Control board – Burkert model 1094 EV
- Vapour recovery pump(s) – Gallagher model Zephyr 8 or Zephyr 24.

(ii)  **or automatic monitoring of the vapour to fuel ratio:**

- TÜV M-20.1 NSW

and the only approved system components are:

- Vaporix model control monitor
- Vafnir model Vaporix flowmeter.

## 6. Description of Variant 5

**approved on 27/09/13**

A Gallagher model CX8P fuel dispenser for motor vehicles for dispensing Diesel Exhaust Fluid (DEF) in attendant-operated mode, or in attended self-service mode using any compatible (#) approved control console. The meter is adjusted to be correct for the liquid for which is verified.

(#) ‘Compatible’ is defined to mean that no additions/changes to the hardware/software specified in this approval are required for satisfactory operation of the complete system.

## 6.1 Field of Operation

The field of operation of the measuring system is determined by the following characteristics:

- Minimum measured quantity,  $V_{min}$  2 L
  - Maximum flow rate,  $Q_{max}$  40 L/min
  - Minimum flow rate,  $Q_{min}$  4 L/min
  - Maximum pressure of the liquid,  $P_{max}$  320 kPa
  - Minimum pressure of the liquid,  $P_{min}$  50 kPa
  - Dynamic viscosity 1.4 mPa.s (at 25°C) (##)
  - Maximum temperature of the liquid,  $T_{max}$  30°C
  - Minimum temperature of the liquid,  $T_{min}$  0°C
  - Ambient temperature range -10 to 55°C
  - Accuracy class 0.5
- (##) The model CX8P dispenser is adjusted to be correct for Diesel Exhaust Fluid (AUS32 - aqueous urea solution 32.5%) for which it is to be verified.

## 6.2 Description of the Metering System

The model CX8P dispenser incorporates the following components:

- A Tatsuno model FM1022 4-piston positive displacement meter, one for each nozzle. Each meter is fitted with a PEC model #07434 or PAT 29227 pulse generator that communicates the volume throughput to the indicator.
  - A 16 mm Elaflex ZVA nozzle and 16 mm hose.
  - A Parker model 2212S20F or other compatible (#) control valve.
  - May also be used with submersible turbine pump as described in Variant 3.
- (#) 'Compatible' is defined to mean that no additions/changes to the hardware/software specified in this approval are required for satisfactory operation of the complete system.

## 7. Description of Variant 6

**approved on 6/12/13**

For use with a Bennett model T140 pump/strainer/gas separator (Figure 9) replacing the Tatsuno unit described for the pattern. A gas/air test valve is provided for checking the operation of the gas elimination device. The pumping unit has the following characteristics:

- Maximum flow rate,  $Q_{max}$  140 L/min
  - Maximum pressure of the liquid,  $P_{max}$  350 kPa
  - Minimum pressure of the liquid,  $P_{min}$  70 kPa (#1)
  - Accuracy class 0.5
  - Applicable liquids Petrol, diesel, kerosene
- (#1) Minimum pressure required for effective operation of the gas elimination device.

## 8. Description of Variant 7

**approved on 26/02/14**

To allow the simultaneous operation of multiple hoses on each side of the dispenser. The 'Dollars', 'Litres' and 'Unit Price' will be displayed simultaneously for the product dispensed from each hose.

**9. Description of Variant 8 provisionally approved on 7/06/16**

For use for blending, where the dispenser allows two base grades of fuel to be supplied into a common third hose for the delivery of the blended product. One hose for low octane fuel only, one hose for high octane fuel only and one hose delivering a defined blend of the two base grades. The blending ratio cannot be changed by the customer.

When a blended product is selected and delivery is initiated by lifting the nozzle, the calculator/indicator starts both pumping units for the two base products - the solenoid valves to the hose are fully opened and the proportional flow control valves begin to operate ramping up to the pre-determined flow rate. The calculator/indicator oversees the pulser output of each meter so that the correct ratio of the two products is maintained.

**10. Description of Variant 9 approved on 19/04/24**

With pumps as described for the pattern with standard flow hoses and compatible ZVA Elaflex nozzles and known as standard flow rate fuel dispensers with the following field of operation:

- Maximum flow rate,  $Q_{max}$  60 L/min
- Minimum flow rate,  $Q_{min}$  5 L/min

Dispensers may contain a combination of standard and high flow hydraulics such that some hoses will have a  $Q_{max}$  60 L/min and other hoses will have a  $Q_{max}$  of 80 L/min. The dispenser will be marked as Q Max 60/80 L/min.



TABLE 1 – Approved Models of the Pulse Series

Models numbers are in the form 'model Pulse CX8P' (the pattern), where:

**First position; shape of the device**

- L An L-shaped dispenser with all the hoses at one end
- C A compact dispenser with hoses on either side of the display
- P A pedestal mounted device

**Second position; the base size and arrangement**

- X large base
- S Small base
- N Nano base
- A Back to back model with two large bases
- B Back to back with one large base and one small base
- E Back to back model with two small bases
- F Back to back model with one large and one nano base
- G Back to back model with two nano bases
- H Back to back model with one small and one nano base
- U Ultra large base to accommodate 5 pumping units

**Third position; the number of hoses**

A hexadecimal number from 1 to F, where F = 15 hoses

**Fourth position; the type of device.**

- P A suction device using pump/s and air separator/s
- D A dispenser with the product supplied under pressure from a submersible turbine pump (STP) hydraulic system/s
- M Mixed, a device with products requiring pressure and suction

## TEST PROCEDURE No 5/6A/229

Instruments shall be tested in accordance with any relevant tests specified in the National Instrument Test Procedures.

The instrument shall not be adjusted to anything other than as close as practical to zero error, even when these values are within the maximum permissible errors.

### **Maximum Permissible Errors**

The maximum permissible errors are specified in Schedule 1 of the *National Trade Measurement Regulations 2009*.

FIGURE 5/6A/229 – 1



Gallagher Model Pulse CX8P Fuel Dispenser for Motor Vehicles – The Pattern

FIGURE 5/6A/229 – 2



Tatsuno Model FP1001 Pump/strainer/gas Separator Units – The Pattern

FIGURE 5/6A/229 – 3



Tatsuno Model MP-02515 Meters With Pulse Generators – The Pattern  
(Also Shows a Vacuum Pump – Variant 4)

FIGURE 5/6A/229 – 4



(a) Using a Lead Seal

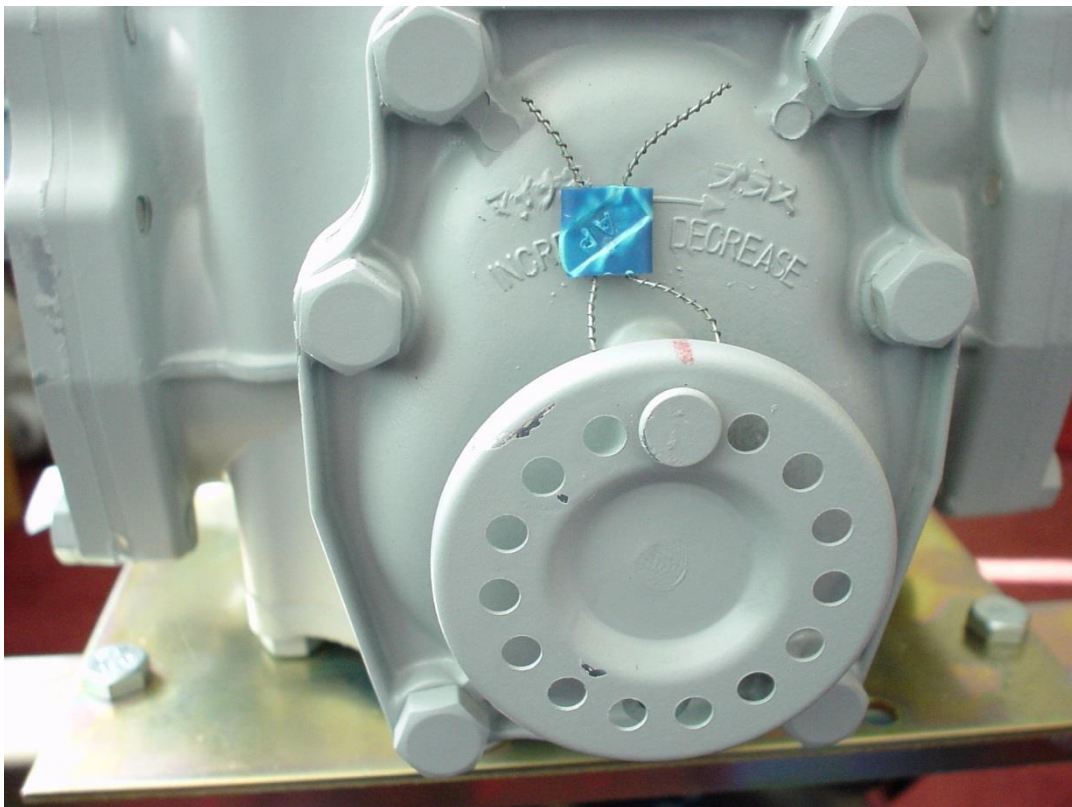

(b) Using a Plastic Seal

Typical Mechanical Sealing of The Flowmeter

FIGURE 5/6A/229 – 5



Gallagher Model Pulse LX8P Fuel Dispenser for Motor Vehicles – Variant 1

FIGURE 5/6A/229 – 6

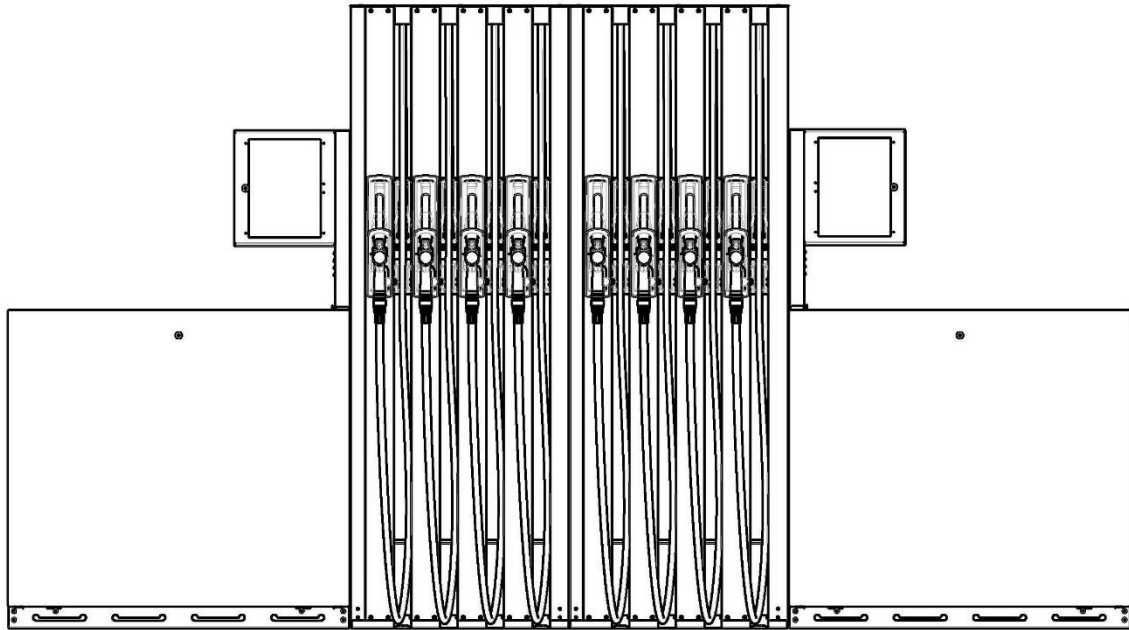

Typical Pulse L\*16\* Series ('Back to back' style) Fuel Dispenser – Variant 1

FIGURE 5/6A/229 – 7

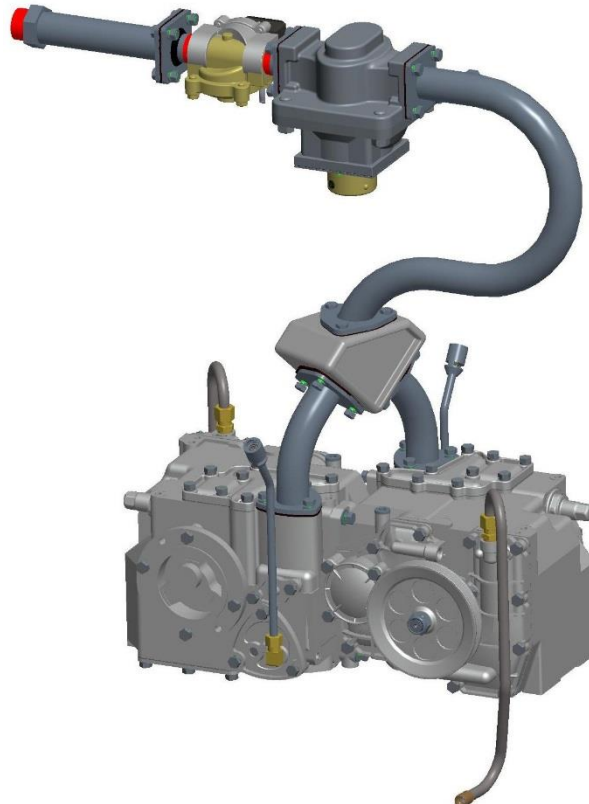

With Two Tatsuno Model FP1001 Pump/strainer/gas separators Feeding a Single Tatsuno Model FM-1002-A21#001 Lobetype Meter – Variant 2

FIGURE 5/6A/229 – 8



Gallagher Model Pulse LX8P Fuel Dispenser for Motor Vehicles – Variant 1  
(Also Shows a Vacuum Pump and Coaxial Adapters – Variant 4)

FIGURE 5/6A/229 – 9



Bennett Model T140 Pump/Strainer/Gas Separator – Variant 6

~ End of Document ~