



Australian Government  
Department of Industry,  
Innovation and Science

## National Measurement Institute

36 Bradfield Road, West Lindfield NSW 2070

### Certificate of Approval NMI 13/1/31

Issued by the Chief Metrologist under Regulation 60  
of the  
*National Measurement Regulations 1999*

This is to certify that an approval for use for trade has been granted in respect of the instruments herein described.

Freightsnap Model FS-5000 Dimensional Measuring Instrument

submitted by Freightsnap LLC  
7907 Bond Street  
Lenexa KS 66214  
USA

**NOTE:** This Certificate relates to the suitability of the pattern of the instrument for use for trade only in respect of its metrological characteristics. This Certificate does not constitute or imply any guarantee of compliance by the manufacturer or any other person with any requirements regarding safety.

This approval has been granted with reference to document NMI R 129, *Multi-dimensional Measuring Instruments*, dated July 2004.

This approval is subject to review at the decision of the Chief Metrologist in accordance with the conditions specified in the document NMI P 106.

#### DOCUMENT HISTORY

Rev	Reason/Details	Date
0	Pattern approved – certificate issued	29/07/19
1	Variant 1 approved – certificate issued	25/11/24

## CONDITIONS OF APPROVAL

### General

Instruments purporting to comply with this approval shall be marked with approval number 'NMI 13/1/31' and only by persons authorised by the submitter.

It is the submitter's responsibility to ensure that all instruments marked with this approval number are constructed as described in the documentation lodged with the National Measurement Institute (NMI) and with the relevant Certificate of Approval and Technical Schedule. Failure to comply with this Condition may attract penalties under Section 19B of the National Measurement Act and may result in cancellation or withdrawal of the approval, in accordance with document NMI P 106.

Auxiliary devices used with this instrument shall comply with the requirements of General Supplementary Certificate No S1/0B.

### Special

Instruments are only approved for use for determination of the dimensions and volume of the smallest rectangular box that could contain an object, for the purposes of determining freight or postal charges.

The dimensions determined may also be used for the calculation (by peripheral equipment) of a volume and/or 'dimensional weight' (\*) value of the object, also for the purposes of determining freight or postal charges.

- (\*) A 'dimensional weight' value is a calculated value deemed to be a weight value obtained by applying a conversion factor to the object's volume.

Signed by a person authorised by the Chief Metrologist to exercise their powers under Regulation 60 of the *National Measurement Regulations 1999*.



**Darryl Hines**  
Manager  
Policy and Regulatory Services

## TECHNICAL SCHEDULE No 13/1/31

### 1. Description of Pattern approved on 29/07/19

A Freightsnap model FS-5000 dimensional measuring instrument (Figure 1) which is approved for use for the determination of the linear dimensions of certain objects while they are in motion. Instruments may be fitted with output sockets (output interfacing capability) for the connection of auxiliary and/or peripheral devices.

#### 1.1 Details

The pattern is approved for use for the determination of the linear dimensions of rectangular box-shaped (parallelepiped (#), cuboidal) or irregular shaped objects having maximum dimensions (i.e. length × width × height) of 240 × 240 × 240 cm and minimum dimensions 30 × 30 × 30 cm, with a scale interval of measurement (*d*) of 2 cm.

The pattern converts the detected characteristics into the linear dimensions of the smallest rectangular box (parallelepiped – #) that would fully contain the object.

The pattern is approved for use in measuring the linear dimensions of opaque objects only; the dimensions determined may also be used for the calculation of volume and/or 'dimensional weight' value (\*) of the item (refer to the Special Conditions of Approval).

Note: This instrument is NOT suitable for:

- transparent objects and objects packed in thick, transparent wrapping material, e.g. 'bubble wrap'; or
- objects with a black colour.

Objects are measured statically by being positioned manually and must be located in the centre of the defined measurement area.

- (#) A rectangular box (parallelepiped) is a polyhedron having six faces that are parallel in pairs; each face is a parallelogram and adjacent edges are perpendicular.
- (\*) A 'dimensional weight' value is a calculated value deemed to be a weight value obtained by applying a conversion factor to the object's volume as calculated from the measured dimensions.

#### 1.2 Dimensioning System

The pattern includes five 3D sensors mounted on a supporting frame above a defined measurement area (Figure 1). The sensors are positioned on the frame to view of all sides of the object to be measured.

Measurement data from the 3D sensors (Figure 2) is transmitted over Ethernet connection to the PC controller.

- (\*) 'Equivalent' is defined to mean other proprietary equipment of the same or better specifications requiring no changes to the software specified in this approval for satisfactory operation of the system

### 1.3 PC Controller

The Freighsnap model FS-5000 includes a PC-based device that connects to the Dimensioning Camera to receive and process the measurement data. The PC operates on a Microsoft Windows based operating system running software FSOIML\_V2.x software. The software version numbers are displayed by selecting the 'About' menu option.

A display connected to the PC provides an indication of measurement results. The indicator is also used to display any error messages that occur during a measurement operation.

### 1.4 Indications

The display connected to the PC-based controller provides an indication of measurement results (Figure 3), however measurement data from the FS-5000 may also be made available to other systems for indication and/or printing.

Printed and displayed information must be made available for verification and must comply with the requirements set out in document NMI R129, Multidimensional Measuring Instruments, in particular as per the extract below.

7.9.1 Any printed ticket or displayed indication shall include sufficient information to identify the transaction, for example:

- (a) dimensions: length ( $L$ ), width ( $W$ ) and height ( $H$ );
- (b) volume (vol);
- (c) weight ( $Wt$ ) if the instrument includes a weighing instrument;
- (d) dimensional weight (Dim  $Wt$  ... kg or  $DW$  ... kg);
- (e) dimensional tare ( $DT$  ... kg);
- (f) conversion factor ( $F$ );
- (g) quantity for charging, for example dimensions, vol or  $DW$  ... kg;
- (h) price rate and price; and
- (i) date, transaction number or other identification of the object.

*Note 1:* Icons may be used to identify indications.

*Note 2:* When the customer is not present during the measurement process the above information need not be displayed or printed out at the time but shall be available on request.

*Note 3:* The price interval and the price rate shall comply with the national regulations applicable for trade.

7.9.2 A printed ticket shall also contain the following printed or pre-printed information:

- (a) that the dimensions and/or volume shown are those of the smallest rectangular box that fully encloses the object; and
- (b) that the dimensional weight is a calculated value deemed to be a weight value obtained by applying a conversion factor to the object's volume or dimensions.

## 1.5 Descriptive Markings

- (a) Instruments carry the following markings (in the vicinity of the indicating device):

Manufacturer's mark, or name written in full	Freightsnap
Model designation	FS-5000
Serial number of the instrument	.....
Year of manufacture	.....
Pattern approval mark	NMI 13/1/31
Maximum dimensions for each axis	<i>Max</i> ..... mm
Minimum dimensions for each axis	<i>Min</i> ..... mm
Scale interval	<i>d</i> = ..... mm

- (b) Instruments of the pattern carry one or more notices with the following or similar wording:

- Certain reflective or transparent items cannot be measured
- Objects with black surface colour cannot be measured
- Items must be placed in the centre of the measurement area,

## 1.6 Verification Provision

Provision is made for the application of a verification mark.

## 1.7 Sealing Provision

Provision is made for sealing the calibration adjustments in software using an audit trail which records adjustments. The Audit trail is accessed and viewed from within the PC controller.

Provision is also made for sealing the FS-5000 model Dimensioning System by means of sealing wire applied through sealing tabs on both sides of the dimensioning unit housing (Figure 4).

## 2. Description of Variant 1

**approved on 25/11/24**

The variant is approved with the system configured for determination of the linear dimensions of rectangular box-shaped (parallelepiped (#), cuboidal) or irregular shaped objects having maximum dimensions (i.e. length x width x height) of 320 x 240 x 240 cm with a scale interval of measurement (*d*) of 2 cm.

## TEST PROCEDURE No 13/1/31

Instruments shall be tested in accordance with any relevant tests specified in the National Instrument Test Procedures.

Note: Refer to clause **1.4 Indications** – Printed and displayed information must be made available for verification and must comply with the requirements set out in document NMI R 129, *Multi-dimensional Measuring Instruments*, dated July 2004.

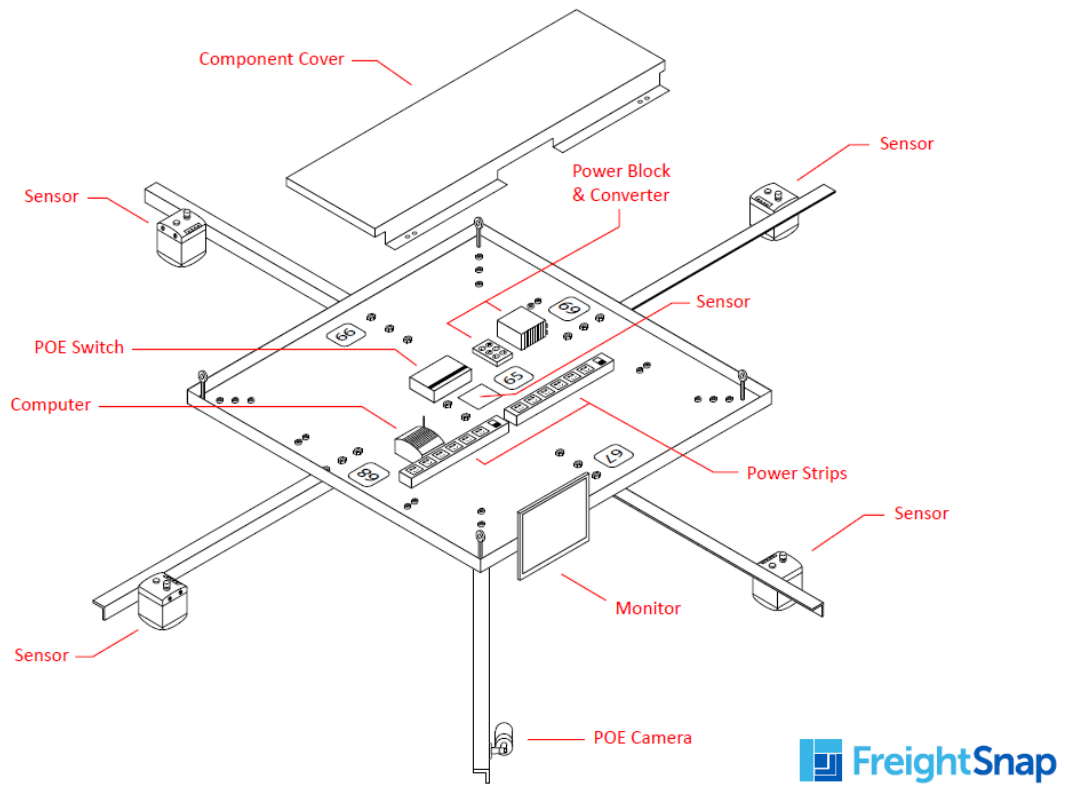
### Maximum Permissible Errors

The maximum permissible errors are specified in the *National Trade Measurement Regulations 2009*.

Instruments shall be tested as follows:

- (a) Test objects shall be used, in the shape of rectangular boxes with known linear dimensions such that each axis (i.e. length × width × height) is tested for at least five dimensions between and including the minimum and maximum dimensions (approximately) specified on the instrument nameplate. Each test object shall be non-sound absorbing, rigid and with flat faces and well-defined edges. All adjacent faces and edges shall be perpendicular to each other. The dimensions shall be equal to  $N \times d$  and the lengths shall be known to an uncertainty equal to or better than  $\pm 1/5$  of the maximum permissible error, which is equal to the scale interval (d). N is a whole number.
- (b) Carry out at least three test runs for each length, varying position and orientation across the receptor. Each measurement shall be within the maximum permissible error.
- (c) Check that instruments are marked in accordance with clause **1.5 Descriptive Markings**.

FIGURE 13/1/31 – 1



Freightsnap Model FS-5000 Dimensional Measuring Instrument

FIGURE 13/1/31 – 2



Freightsnap 3D sensor

FIGURE 13/1/31 – 3

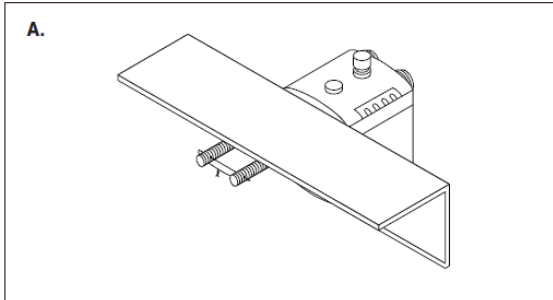


Typical Display

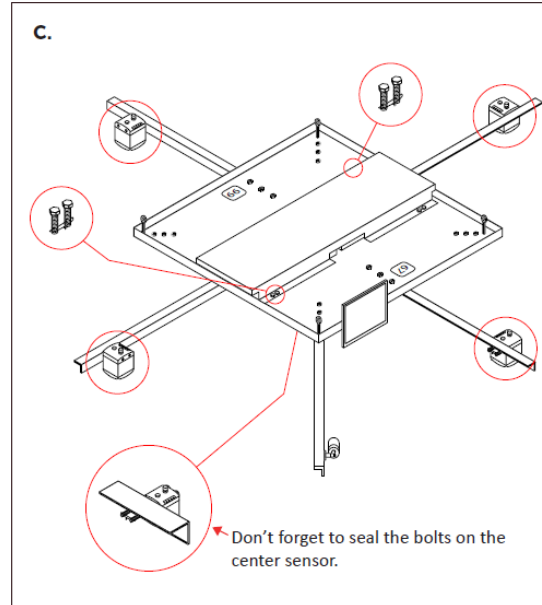
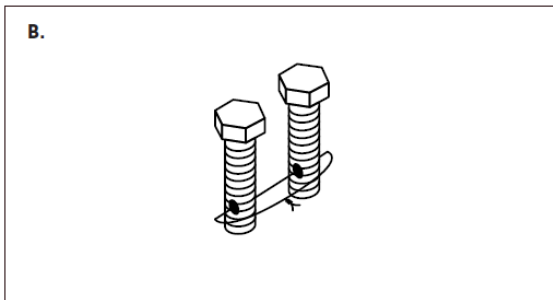


FIGURE 13/1/31 – 4

Step 1) Seal the (5) Sensors at the end of the Sensor Bolts using wire as shown in drawing A. Drawing C shows where all the seals are located on the unit.



Step 2) Seal the Unit Cover at the end of the Unit Cover bolts using wire as shown in drawing B.



Showing Typical Mechanical Sealing Provision on the FS-5000

~ End of Document ~