



Australian Government

Department of Industry,
Science and Resources

**National
Measurement
Institute**

36 Bradfield Road, West Lindfield NSW 2070

Certificate of Approval

NMI 6/4D/391

Issued by the Chief Metrologist under Regulation 60
of the
National Measurement Regulations 1999

This is to certify that an approval for use for trade has been granted in respect of the instruments herein described.

Digi Singapore Model SM-6000 EV HC Weighing Instrument

submitted by W. W. Wedderburn Pty. Limited
101 Williamson Road
Ingleburn NSW 2565

NOTE: This Certificate relates to the suitability of the pattern of the instrument for use for trade only in respect of its metrological characteristics. This Certificate does not constitute or imply any guarantee of compliance by the manufacturer or any other person with any requirements regarding safety.

This approval has been granted with reference to document NMI R 76, *Non-automatic weighing instruments, Parts 1 and 2*, dated October 2015.

This approval is subject to review at the decision of the Chief Metrologist in accordance with the conditions specified in the document NMI P 106.

DOCUMENT HISTORY

Rev	Reason/Details	Date
0	Pattern & variants 1 to 9 approved – certificate issued	01/07/19
1	Variant 10 approved – certificate issued	07/08/20
2	Pattern amended (additional software version) – certificate issued	29/10/20
3	Pattern editorial amendment (Clause 1.10) & variant 11 approved – certificate issued	24/08/22
4	Variant 12 approved – certificate issued	11/06/24
5	Variant 13 approved – certificate issued	04/12/24

CONDITIONS OF APPROVAL

General

Instruments purporting to comply with this approval shall be marked with pattern approval number 'NMI 6/4D/391' and only by persons authorised by the submitter.

It is the submitter's responsibility to ensure that all instruments marked with this approval number are constructed as described in the documentation lodged with the National Measurement Institute (NMI) and with the relevant Certificate of Approval and Technical Schedule. Failure to comply with this Condition may attract penalties under Section 19B of the National Measurement Act and may result in cancellation or withdrawal of the approval, in accordance with document NMI P 106.

Auxiliary devices used with this instrument shall comply with the requirements of General Supplementary Certificate of Approval No S1/0B.

Special Conditions of Approval

Certain aspects of this instrument (in particular transaction record printing formats) are able to be configured by the user. Whilst NMI believes that acceptable formats can be achieved for typical basic sales modes, it is also possible for the instrument to be configured to produce unacceptable formats, and use of some formats may be inappropriate for different sales modes. It is the responsibility of the user to ensure that acceptable and appropriate formats are used in any particular situation.

Signed by a person authorised by the Chief Metrologist to exercise their powers under Regulation 60 of the *National Measurement Regulations 1999*.



Darryl Hines
Manager
Policy and Regulatory Services

TECHNICAL SCHEDULE No 6/4D/391

1. Description of Pattern

**approved on 01/07/19
amended on 29/10/20
amended on 24/08/22**

A Digi Singapore model SM-6000 EV HC class  non-automatic self-indicating price-computing multi-interval weighing instrument (Figure 1) with a verification scale interval (e_1) of 0.002 kg up to 6 kg and a verification scale interval (e_2) of 0.005 kg from 6 kg up to the maximum capacity of 15 kg. The minimum capacity is 0.04 kg. Instruments may also be known as model DIGI SM-6000 EV HC.

Instruments are fitted with an 8 inch colour touchscreen operator display/keyboard, numeric keypad and 8 inch colour customer display all incorporated within the main instrument housing mounted on the side of the load receptor (Figure 1). The operator touchscreen consists of displays for presentation of tare, weight, unit price and price information, zero, and 'net' indicators.

Instruments are fitted with an integral printer, for printing of labels or tickets (#).

Instruments have unit price to \$9999.99/kg, price to \$99999.99, a product look up (PLU) facility and an image and/or product description relating to PLU items may also be displayed.

Instruments may be fitted with output sockets (output interfacing capability) for the connection of auxiliary and/or peripheral devices; this may include wireless networking capabilities.

The instrument operates from mains AC power (220 - 240 V AC, 50 Hz).

(#) Refer to the Special Conditions of Approval in the certificate.

1.1 Zero

A zero-tracking device may be fitted.

The initial zero-setting device of the pattern has a nominal range of approximately 20% of the maximum capacity of the instrument.

The instrument has a semi-automatic zero-setting device with a nominal range of not more than 4% of the maximum capacity of the instrument.

1.2 Tare

A semi-automatic subtractive tare device and/or non-automatic keyboard-entered pre-set subtractive tare device, each of up to 5.998 kg maximum tare capacity, may be fitted.

Pre-set tare values may be associated with product look up (PLU) items.

A separate display of tare values is provided.

1.3 Display Check

A display check is initiated whenever power is applied.

1.4 Levelling

The Instrument is provided with adjustable feet and a level indicator.

The instrument is to be used in a level condition as indicated by the level indicator.

1.5 Additional Features

Instruments may be fitted with a manual weight entry function. This function is intended for use where (for example) the instrument is being used to calculate price and the weight value had been previously determined using a separate weighing instrument.

When this function is operated, the weighing functions (and associated zero and tare functions) of the instrument (pattern and the variants) are disabled. This is indicated by the weight display of the instrument indicating '----'. The manually entered value is displayed separately, in the area otherwise intended for the tare value, and is designated 'Manual Wt kg'.

The manually entered weight value shall be marked 'M' on the receipt and/or label to distinguish this from a value determined by weighing on the instrument.

1.6 Interfaces

The indicator may be fitted with interfaces for the connection of auxiliary and/or peripheral devices. Any interfaces shall comply with clause 5.3.6 of document NMI R 76 (the basic intent of which is that it shall not be possible to alter weighing results via the interfaces).

Any measurement data output from the instrument or its interfaces shall only be used for trade in compliance with NMI General Supplementary Certificate No S1/0B (in particular in regard to the data and its format).

Indications other than the indications of measured mass (i.e. gross, tare, net, totals) displayed either on the indicator or on an auxiliary or peripheral device, are not for trade use.

Instruments may be fitted with cash drawer, RS-232, USB and Ethernet interfaces.

1.7 Verification Provision

Provision is made for the application of a verification mark.

1.8 Descriptive Markings and Notices

Instruments carry the following markings:

Manufacturer's mark, or name written in full	Digi Singapore PTE. LTD.
Name or mark of manufacturer's agent	WEDDERBURN
Indication of accuracy class	
Pattern approval number for the instrument	NMI 6/4D/391
Maximum capacity	<i>Max</i> g or kg #1
Minimum capacity	<i>Min</i> g or kg #1
Verification scale interval	<i>e</i> = g or kg #1
Maximum subtractive tare	<i>T</i> = - g or kg #2
Serial number of the instrument

#1 These markings are shown near the display of the result.

#2 This marking is required if *T* is not equal to *Max*.

Note: For multi-interval instruments the markings shall be as above, with the exception that the 'Maximum capacity' and 'Verification scale interval' shall be marked for both interval ranges, e.g. as follows:

Maximum capacity	<i>Max</i>/..... kg
Verification scale interval	<i>e</i> =/..... kg

1.9 Sealing Provision

Provision is made for the calibration and configuration to be sealed by setting the SPAN switch within the instrument to a DISABLE position, and then preventing access within the instrument housing.

To determine that the switch status is in the 'DISABLE' position as follows:

- Press the 'MENU' button, and the 'MAINTENANCE' button. The maintenance mode is displayed.
- Press the 'MAINTENANCE' button, the 'SCALE' button and then the 'CALIBRATION' key.
- If the switch is in the 'DISABLE' position, the instrument will display 'PLEASE TURN ON SPAN SWITCH'. In this case the instrument may be verified.
- Otherwise 'CAPACITY, INCREMENT, RESOLUTION ...' and the 'NEXT>' button will be displayed in which case the instrument should not be verified until the switch has been correctly located in the 'DISABLE' position.

Provision is made for access to the SPAN switch to be sealed by means of lead and wire type seals with drilled screws, or a destructible adhesive label placed over the securing screw of the sealing cover plate underneath the load receptor as shown in Figure 8.

1.10 Software

The legally relevant software is identified by a scale driver version number protected by a checksum number:

- Version number 7.1.1.23 and checksum number 89E66100; or
- Version number 7.1.1.25 and checksum number F43E2E4E; or
- Version number 7.1.1.31 and checksum number DD724AA2.

Any modification in the scale driver will result in a change in the checksum value and an error being detected.

The instructions for accessing the legally relevant software version are as follows (starting from the normal weighing mode):

- Press the 'MENU' button, and then the 'MAINTENANCE' button on the MENU screen. The maintenance mode is displayed.
- Press the 'SYSTEM INFO' button on the MAINTENANCE MODE screen. The software version numbers are displayed.

2. Description of Variant 1

approved on 01/07/19

Certain other capacities of the Digi Singapore model SM-6000 series of multi-interval instruments as listed in Table 1 below (the pattern is shown in **bold**).

Table 1

Maximum Capacity (Max_1 / Max_2)	Minimum Capacity (Min)	Verification Scale Interval (e_1 / e_2)	Maximum Subtractive Tare Capacity ($T = - \dots$)
3 / 6 kg	0.02 kg	0.001 / 0.002 kg	2.999 kg
6 / 15 kg	0.04 kg	0.002 / 0.005 kg	5.998 kg
15 / 30 kg	0.100 kg	0.005 / 0.010 kg	14.995 kg

3. Description of Variant 2 **approved on 01/07/19**

The Digi Singapore model SM-6000 series of single interval instruments in certain capacities as listed in Table 2 below.

TABLE 2

Maximum Capacity (Max)	Minimum Capacity (Min)	Verification Scale Interval (e)	Maximum Subtractive Tare Capacity (T = - ...)
6 kg	0.020 kg	0.001 kg	2.999 kg
6 kg	0.040 kg	0.002 kg	2.998 kg
15 kg	0.040 kg	0.002 kg	7.498 kg
15 kg	0.100 kg	0.005 kg	7.495 kg
30 kg	0.100 kg	0.005 kg	14.995 kg
30 kg	0.200 kg	0.010 kg	14.99 kg

4. Description of Variant 3 **approved on 01/07/19**

The Digi Singapore model SM-6000 EV HC PLUS (Figure 2) instruments which are similar to the pattern and variants 1 to 2 with a 15 inch operator display and/or a 15 inch customer display.

5. Description of Variant 4 **approved on 01/07/19**

The Digi Singapore model SM-6000 EV (Figure 3) instruments which are similar to the pattern and variants 1 to 2 but as an 'elevated' style instruments with the main instrument housing mounted on a column above the load receptor.

6. Description of Variant 5 **approved on 01/07/19**

The Digi Singapore model SM-6000 EV PLUS (Figure 7) instruments which are similar to variant 4 but with a 15 inch operator display and/or a 15 inch customer display.

7. Description of Variant 6 **approved on 01/07/19**

Variants 4 and 5 with an additional printer fitted below the numeric keypad (Figure 4).

8. Description of Variant 7 **approved on 01/07/19**

The Digi Singapore model SM-6000 SSP (Figure 5) instruments which are similar to variant 4 but without a customer display in which case instruments are either:

- (a) NOT FOR TRADING DIRECT WITH THE PUBLIC in which case instruments carry a notice to this effect; or
- (b) Used in a self-service arrangement which provides various methods of product look up, as well as providing tare, weight, unit price and price

displays. A display of tare values (which may be stored against PLU items) is also provided.

Note 1: It is not required that access to the zero setting facility be available to customers in a self-service arrangement. However access to the zero setting facility shall be available to staff of the particular store, and it is expected that measures will be in place to ensure that the zero condition of the instrument is checked regularly.

Note 2: When used in a self-service arrangement, all keys on the touch screen keyboard, other than the REZERO key, may be disabled or removed. The TARE key is not functional with this arrangement.

Note 3: The use of totalisation across instruments ('floating system') arrangement is not approved for use in self-service arrangement.

Note 4: The use of manual weight entry function is not approved for use in self-service arrangement.

9. Description of Variant 8 **approved on 01/07/19**

The Digi Singapore model SM-6000 SSP HC (Figure 6) instruments which are similar to the pattern and variants 1 to 2 but with a 15 inch operator display and used in a self-service arrangement similar to variant 7b without a customer display.

10. Description of Variant 9 **approved on 01/07/19**

The pattern and variants may be connected in a network with compatible approved Teraoka instruments, to share common PLU data, for totalisation across instruments ('floating system'), and to accumulate and retrieve management information.

In addition, the network may be interfaced with a computer for the collection of management data, or the downloading of PLU data.

Note 1: The weighing and price-computing functions of each weighing instrument in the network are independent, and the removal, repair or replacement of a particular weighing instrument does not necessitate reverification of any other weighing instrument in the network.

11. Description of Variant 10 **approved on 07/08/20**

The pattern or variants may have an alternative 'dish' platter (Figure 9).

The instrument shall be verified with the 'dish' platter.

12. Description of Variant 11 **approved on 24/08/22**

The Digi Singapore models SM-6000 SSP (Figure 5) and SM-6000 SSP HC (Figure 6) instruments used in bring your own (BYO) container self-service arrangement:

(a) Used in a BYO container self-service arrangement which provides various methods of product look up, as well as providing tare, weight, unit price and price displays. A display of tare values (which are stored against BYO containers) is also provided.

(b) The instrument provides a sequence of operations intended to ensure correct transaction measurement, including maintaining the zero condition of the instrument. If the instrument is not at zero when there is no load on the load receptor, an instruction is provided on the screen to request manual intervention of a supervisor/shop staff member to zero.

A label with tare value, net weight, unit price and price to pay shall be printed after net weighing. Printing below minimum capacity shall not be possible.

- (c) The trader making the weighing instrument available for direct use by the public is responsible for ensuring the instrument is used correctly to achieve correct transaction measurements. Sufficiently clear instructions shall be given to the public (the operators) to enable them to correctly obtain a tare (container weight) and an accurate net weight.

Note 1: It is not required that access to the zero setting facility be available to the public (the operators) in a BYO container arrangement. However access to the zero setting facility shall be available to staff of the particular store, and it is expected that measures will be in place to ensure that the zero condition of the instrument is checked regularly.

Note 2: When used in a BYO container arrangement, all function keys on the operator touch screen are hidden (except for buttons available to the public for performing self-service operations).

Note 3: The use of totalisation across instruments ('floating system') arrangement is not approved for use in BYO container arrangement.

Note 4: The use of manual weight entry function is not approved for use in a BYO container arrangement.

12.1 Software

The legally relevant software is identified by a scale driver version number protected by a checksum number:

- Version number 7.1.1.23 and checksum number 89E66100; or
- Version number 7.1.1.25 and checksum number F43E2E4E; or
- Version number 7.1.1.31 and checksum number DD724AA2.

Any modification in the scale driver will result in a change in the checksum value and an error being detected.

The BYO container self-service application software is designated VERSION 24.60.58-1-rc1 or greater.

The instructions for accessing software versions are as follows (starting from the normal weighing mode):

- Touch four corners of the display area for presentation of tare, weight, unit price and total price in clockwise direction started at the top-left corner.
 - Key in the passcode '1234' (#1) and press the 'ENTER' button.
 - Press the 'QUIT' button to enter the MENU mode.
 - Press the 'MAINTENANCE' button. The maintenance mode is displayed.
 - Press the 'SYSTEM INFO' button. The software version numbers are displayed.
- (#1) An alternative passcode may be set up by the store/owner for a specific weighing instrument. Where the generic passcode '1234' does not unlock the MENU screen, a unique store passcode should be obtained from the store manager (or their representative).

13. Description of Variant 12

approved on 11/06/24

The All-in-one bulk system is a class III non-automatic self-indicating price-computing measuring instrument (Figure 10) with the following individual instruments:

- Digi Singapore, model SM-6000 Printer Console
- Digi Singapore, model HS-1000 Hopper non-automatic, self-indicating, price-computing weighing instrument.
- Digi Singapore, model SBS-1000 non-automatic, self-indicating, price-computing weighing instrument.
- Digi Singapore, model SBS-1000Q non-automatic, self-indicating, price-computing weighing instrument.

The metrological specifications are defined by each individual weighing instrument that forms this All-in-one bulk system and marked so.

This system is intended as a self-service arrangement that provides a label for the weight of the product and prices based on determined weight x unit price.

13.1 Digi Singapore model SBS-1000 weighing instrument

Digi Singapore model SBS-1000 (Figure 11a) class III non-automatic self-indicating, price-computing single range weighing instrument with the specification in Table 3.

Table 3

Maximum Capacity (<i>Max</i>)	Minimum Capacity (<i>Min</i>)	Verification Scale Interval (<i>e</i>)	Zemic Load Cell, Model L6D (<i>E_{max}</i>)
30 kg	0.1 kg	0.005 kg	50 kg

The instrument is formed as scoop weighing instrument in the All-in-one bulk system. The instrument displays “Purchased Weight”, “Gross Weight”, “Unit Price”, and “Total Price”.

The operation of the scoop weighing instrument is as follows:

- The container with the product is placed on the instrument. The “Gross Weight” on the instrument shall be less than or equal to the maximum capacity of the instrument.
- When the product is taken from the container via the scoop, then the instrument shall display the weight of the product taken out on the “Purchased Weight” indicator, and the “Gross Weight” indicator shall display the total remaining weight measured by the Scoop Scale. The “Total Price” is calculated based on the “Unit Price” and “Purchased Weight”.
- Press the “GO” button to accept the purchase weight”. The instrument will send the transaction to SM-6000 Printer Console and print out the label.

The software version in the instrument is u01.xx (where xx = 03 or greater) and is indicated on the weight display on startup (when the weighing instrument is powered on).

Sealing is achieved by wire seal through screw or via labels to prevent removal of the cover plate under the scale (Figure 11b).

13.2 Digi Singapore model SBS-1000Q weighing instrument

Digi Singapore model SBS-1000Q (Figure 12a) class III non-automatic self-indicating, price-computing single range weighing instrument with the specification in Table 3.

The instrument is formed as liquid weighing instrument in the All-in-one bulk system. The instrument displays “Purchased Weight”, “Gross Weight”, “Unit Price” and “Total Price”.

The operation of the liquid weighing instrument is as follows:

- The container with the liquid product is placed on the instrument. The “Gross Weight” on the instrument shall be less than or equal to the maximum capacity of the instrument and displayed on the indicator.
- When the product is dispensed from the container, then the instrument shall display the weight of the product taken out on the “Purchased Weight” indicator, and the “Gross Weight” indicator shall display the weight value that is the total remaining weight measured by the Liquid Scale. The “Total Price” is calculated based on the “Unit Price” and “Purchased Weight”.
- Press the “GO” button to accept the “Purchased Weight”. The instrument will send the transaction to SM-6000 Printer Console and print out the label.

The software version in the instrument is ‘u01.xx’ (where xx = 03 or greater) and is indicated on the display on startup (when the weighing instrument is powered on).

Sealing is achieved by wire seal through screw or via labels to prevent removal of the cover plate under the scale (Figure 12b).

13.3 Digi Singapore model HS-1000 weighing instrument

Digi Singapore model HS-1000 (Figure 13a) class III non-automatic self-indicating, price-computing single range weighing instrument with the specification in Table 4.

Table 4

Maximum Capacity (<i>Max</i>)	Minimum Capacity (<i>Min</i>)	Verification Scale Interval (<i>e</i>)	Zemic Load Cell, Model L6D (<i>E_{max}</i>)
1.5 kg	0.01 kg	0.0005 kg	3 kg
3 kg	0.02 kg	0.001 kg	5 kg
6 kg	0.04 kg	0.002 kg	12 kg
7.5 kg	0.1 kg	0.005 kg	15 kg

The instrument may be configured to class III multi-interval non-automatic self-indicating, price-computing single range weighing instrument with the specification in Table 5.

Table 5

Maximum Capacity (Max_1/Max_2)	Minimum Capacity (Min)	Verification Scale Interval (e_1/e_2)	Zemic Load Cell, Model L6D (E_{max})
0.5 kg / 1 kg	0.01 kg	0.0005 kg / 0.001 kg	3 kg
1 kg / 2 kg	0.02 kg	0.001 kg / 0.002 kg	5 kg
2 kg / 5 kg	0.1 kg	0.002 kg / 0.005 kg	12 or 15 kg

The instrument is formed as hopper weighing instrument in the All-in-one bulk system. The instrument displays “Weight”, “Unit Price”, and “Total Price”.

The operation of the hopper weighing instrument is as follows:

- When the product is dispensed from the container to the hopper, the instrument shall display the weight of the product on the “Weight” indicator, The “Total Price” is calculated based on the “Unit Price” and “Weight”.
- Press down on the lever to the right of the displays to accept the purchase weight and release the product to the customer’s container, and the instrument will send the transaction to SM-6000 Printer Console and print out the label.

The software version in the instrument is ‘u01.xx’ (where xx = 03 or greater) and is displayed on the weight display on startup (when the weighing instrument is powered on).

Sealing is achieved by wire seal through screw or via labels to prevent removal of cover plate under the scale (Figure 13b).

13.4 Digi Singapore model SM-6000 Printer Console

The Digi Singapore model SM-6000 Printer Console (Figure 14a) is connected to a combination of HS-1000, SBS-1000 or SBS-1000Q weighing instruments via Ethernet patch cables, and provides printing function and PLU set up function, where identification of item and unit price of each attached weighing instrument is entered.

After receiving the transaction from the connected weighing instrument, the SM-6000 Printer Console displays the following information for each weighed item (multiple items can be displayed at the same time upon the SM-6000 display):

- Measurement instrument product identification (e.g., Liquid scale 2)
- Unit price which is the same as the unit price on the weighing instrument that matched measurement instrument product
- Weight value which is the same as the weight value on the weighing instrument that matched measurement instrument product identification
- Price which is the same as the total price on the weighing instrument that matched measurement instrument product identification

The software version in the instrument is ‘24.xx.yy-zz’ (where xx = 60 or greater, yy = 58 or greater and zz = is any numeric code).

The instructions for accessing software versions are as follows (starting from the normal weighing mode):

1. Touch four corners of the display area for presentation of tare, weight, unit price and total price in clockwise direction started at the top-left corner.
 2. Key in the passcode '1234' (#1) and press the 'ENTER' button.
 3. Press the 'QUIT' button to enter the MENU mode.
 4. Press the 'MAINTENANCE' button. The maintenance mode is displayed.
 5. Press the 'SYSTEM INFO' button. The software version number is displayed.
- (#1) An alternative passcode may be set up by the store/owner for a specific weighing instrument. Where the generic passcode '1234' does not unlock the MENU screen, a unique store passcode should be obtained from the store manager (or their representative).

Sealing of the software SD card is achieved by application of a destructible seal over the card as shown in Figure 14b.

14 Description of Variant 13

approved on 04/12/24

The SM-6000 G series instruments which are similar to the models stated in the pattern and variants 3, 4, 5, 7, 8, 11 and 12 but contain upgraded CPU, mainboard, checksum and operation system (Linux 10 (64 bits) or Linux 12 (64 bits)), and as multi-interval instruments in certain capacities as listed in Table 1 (Variant 1) and as single interval instruments in certain capacities as listed in Table 2 (Variant 2).

- SM-6000 EV HC G is similar to the pattern instrument.
- SM-6000 EV HC PLUS G is similar to Variant 3.
- SM-6000 EV G is similar to Variant 4.
- SM-6000 EV PLUS G is similar to Variant 5.
- SM-6000 SSP G is similar to Variant 7 and Variant 11.
- SM-6000 SSR G (Figure 15 a) is similar to Variant 7 but with a dish platter like Variant 10.
- SM-6000 SSP AI G (Figure 15 b) is a Smart Recognition scale in a similar shape to Variant 7 but fitted with a camera to identify product.
- SM-6000 SSP HS G is similar to Variant 8.
- SM-6000 SSR HS G is similar to Variant 8 but with a dish platter like Variant 10.
- SM-6000 G Printer Console - is similar to console used in Variant 12 (All-in-one bulk system).

14.1 Software

The legally relevant software is identified by a scale driver version number protected by a checksum number (Figure 16):

- Version number 8.1.1.40 and checksum number 18425002.

The software version of the instrument is 30.xx.yy-zz (where xx = 65 or greater, yy = 63 or greater and zz = is any numeric code).

The instructions for accessing the legally relevant software version are as follows (starting from the normal weighing mode):

- Press the 'MENU' button, and then the 'MAINTENANCE' button on the MENU screen. The maintenance mode is displayed.

- Press the 'SYSTEM INFO' button on the MAINTENANCE MODE screen. The software version numbers are displayed.

14.2 Sealing

The sealing provision is the same as the pattern and Figure 8.

TEST PROCEDURE No 6/4D/391

Instruments shall be tested in accordance with any relevant tests specified in the National Instrument Test Procedures.

Maximum Permissible Errors

The maximum permissible errors are specified in Schedule 1 of the *National Trade Measurement Regulations 2009*.

Tests

For multi-interval and multiple range instruments with verification scale intervals of e_1 , e_2 ..., apply e_1 for zero adjustment, and maximum permissible errors apply e_1 , e_2 ..., as applicable for the load.

Additional tests for instruments fitted with a **PURCHASED WEIGHT** indicating device

Applicable models in variant 12:

- 1) Digi Singapore model SBS-1000 weighing instrument and;
- 2) Digi Singapore model SBS-1000Q weighing instrument.

After the verification test procedures using the GROSS WEIGHT display indication, the following test procedure shall be carried out using the **PURCHASED WEIGHT** display indication.

Criteria for selecting loads to be removed from the load receptor:

- Use at least five different loads.
- The loads must span from minimum to maximum capacity of the instrument in approximately equal steps.
- Include the loads at each MPE change point.

The test load shall be progressively decreased on the load receptor.

- A) Empty the load receptor and zero the instrument.
- B) Apply the maximum capacity load on the load receptor, and confirm the 'Gross Weight' indication is within the MPE.
- C) Press the 'Go' button twice to activate the 'PURCHASED WEIGHT' display indication.
- D) Remove the loads from the load receptor until the load receptor is empty. The 'PURCHASED WEIGHT' display indicates the load removed.
- E) Determine if the 'PURCHASED WEIGHT' is within the MPE for each load removed (refer to NITP 6.1 to 6.4 Clause 4.1 for MPE check).
- F) Determine whether the instrument has passed or failed.

FIGURE 6/4D/391 – 1



Digi Singapore Model SM-6000 EV HC Weighing Instrument (Pattern)

FIGURE 6/4D/391 – 2



Digi Singapore Model SM-6000 EV HC PLUS Weighing Instrument (Variant 3)

FIGURE 6/4D/391 – 3



Digi Singapore Model SM-6000 EV Weighing Instrument (Variant 4)

FIGURE 6/4D/391 – 4



Digi Singapore Model SM-6000 EV Series Weighing Instruments With Additional Printer (Variant 6)

FIGURE 6/4D/391 – 5



Digi Singapore Model SM-6000 SSP Weighing Instrument (Variant 7)

FIGURE 6/4D/391 – 6



Digi Singapore Model SM-6000 SSP HS Weighing Instrument (Variant 8)

FIGURE 6/4D/391 – 7

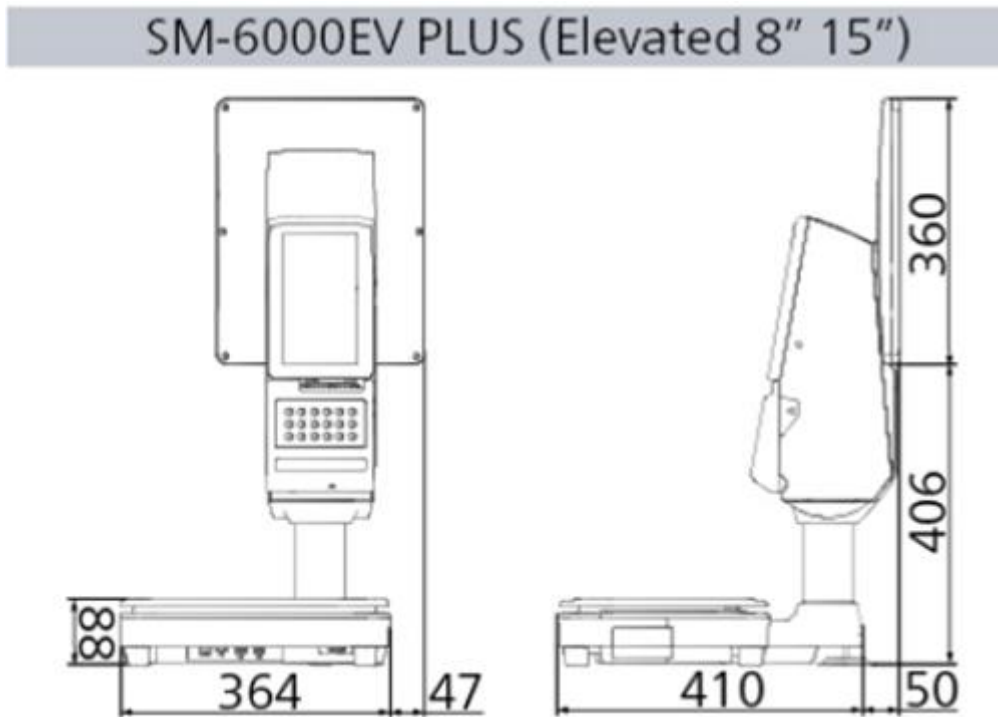

Digi Singapore Model SM-6000 EV PLUS Weighing Instrument (Variant 5)

FIGURE 6/4D/391 – 8

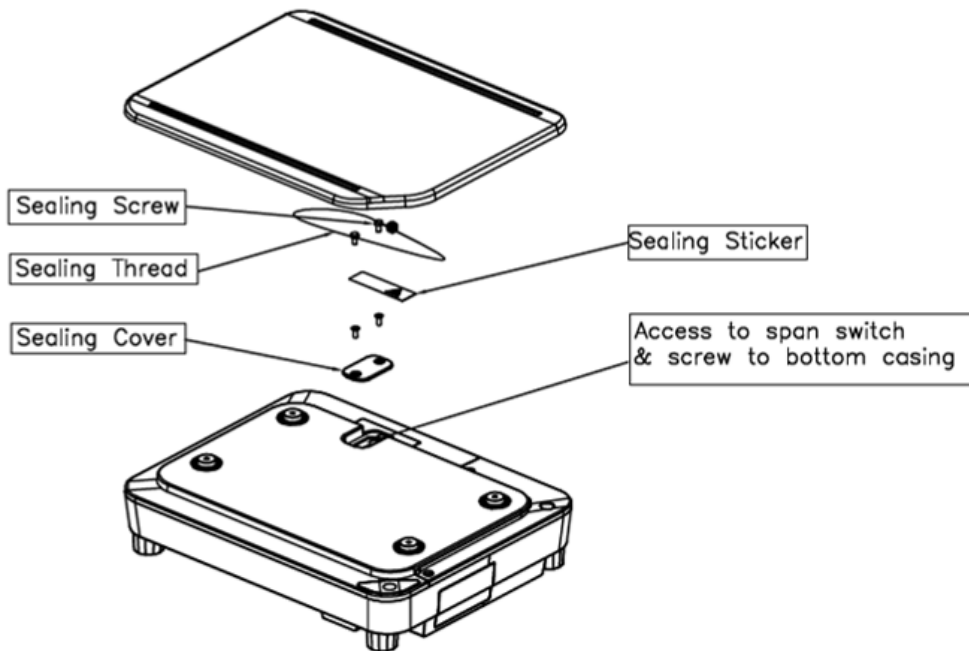

Typical Sealing

FIGURE 6/4D/391 – 9



Digi Singapore Model SM-6000 Series Weighing Instrument with a 'dish' Platter
(Variant 10)

FIGURE 6/4D/391 – 10



All-in-One Bulk System

FIGURE 6/4D/391 – 11



a) Digi Singapore Model SBS-1000 Weighing Instrument

Bottom View

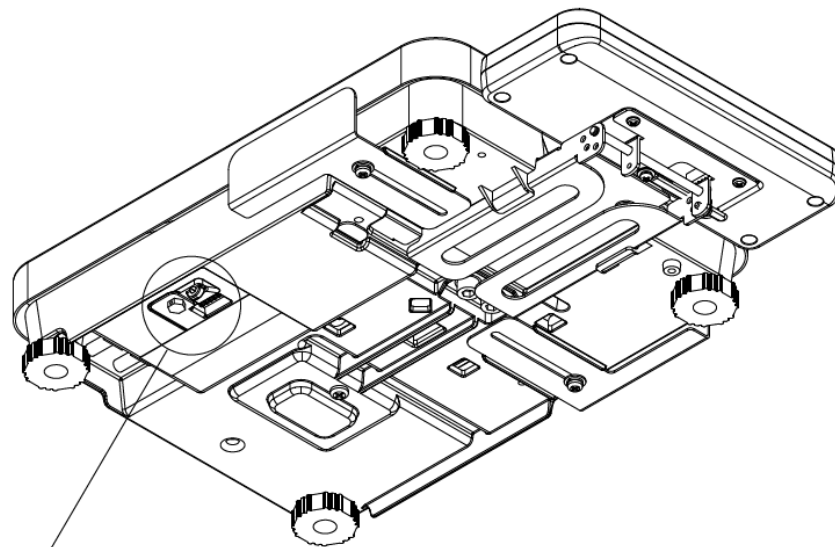

Sealing Position

b) Typical Sealing of SBS-1000 Weighing Instrument

FIGURE 6/4D/391 – 12



a) Digi Singapore Model SBS-1000 Weighing Instrument

Bottom View

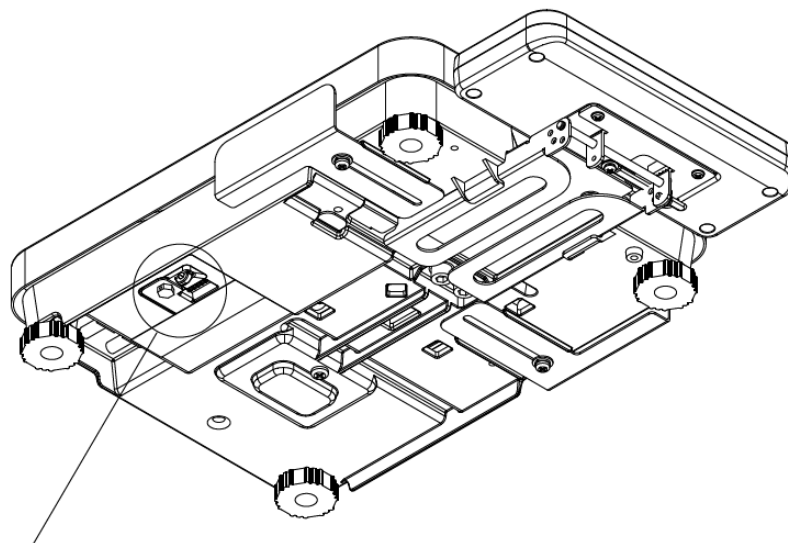

Sealing Position

b) Typical Sealing of SBS-1000Q Weighing Instrument

FIGURE 6/4D/391 – 13



a) Digi Singapore Model HS-1000 Hopper Weighing Instrument

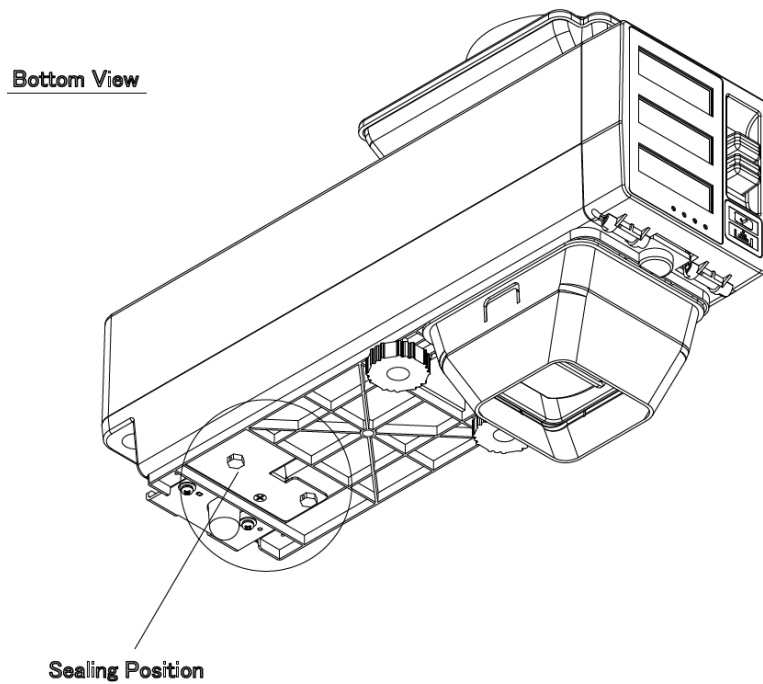

b) Typical Sealing of HS-1000 Hopper Weighing Instrument

FIGURE 6/4D/391 – 14



a) Digi Singapore Model SM-6000 Printer Console

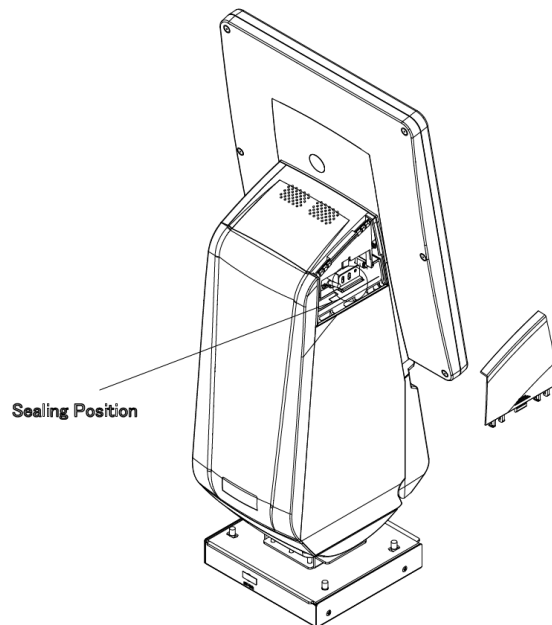

b) Typical Sealing of SM-6000 Printer Console

FIGURE 6/4D/391 – 15



(a) DIGI Model SM-6000 SSR (Variant 13)



(b) DIGI Model SM-6000 SSP AI G (Variant 13)

FIGURE 6/4D/391 – 16

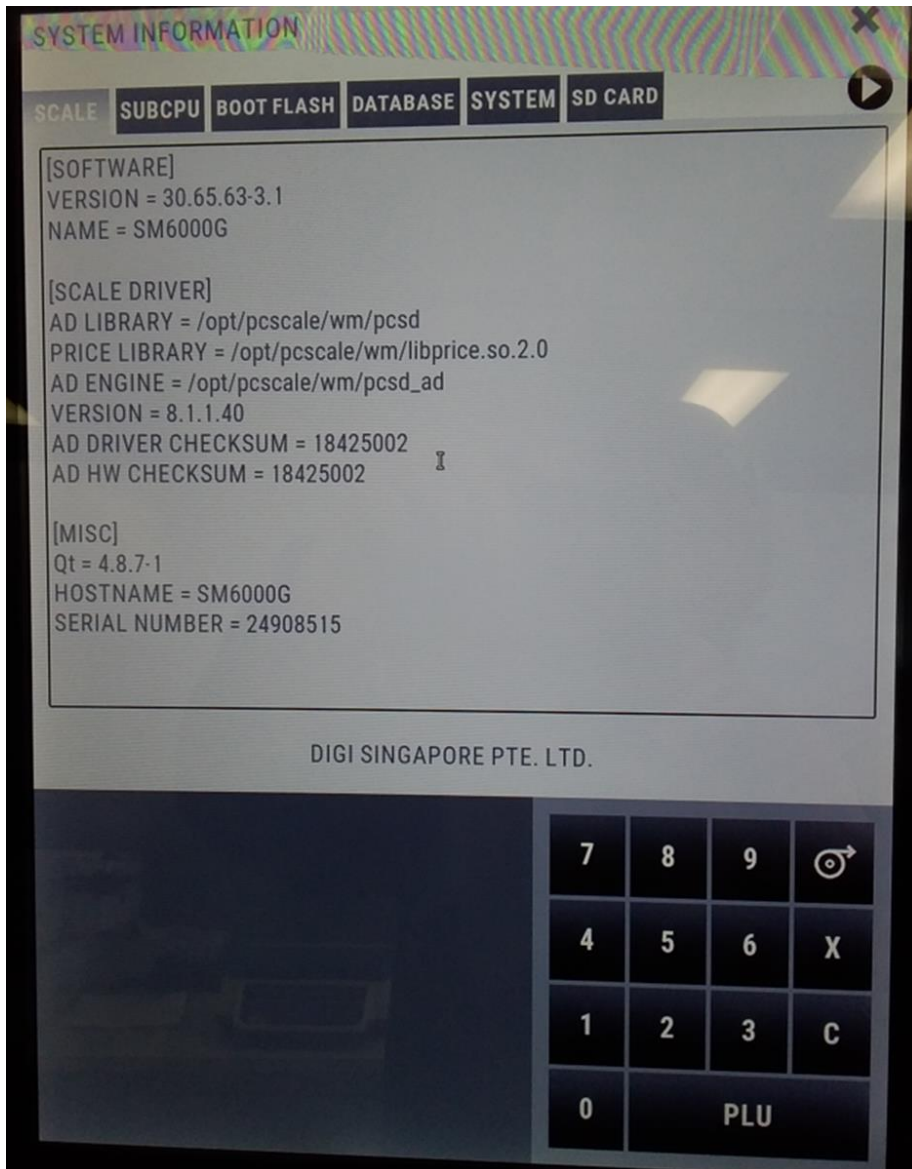

Screen Shot Of Software Version And Checksum Check

~ End of Document ~