



Australian Government
Department of Industry,
Innovation and Science

**National
Measurement
Institute**

36 Bradfield Road, West Lindfield NSW 2070

**Interim
Provisional
Certificate of Approval
NMI P5/1/9**

VALID FOR VERIFICATION PURPOSES UNTIL 1 March 2026

Issued by the Chief Metrologist under Regulation 60
of the
National Measurement Regulations 1999

This is to certify that an approval for use for trade has been granted in respect of the instruments herein described.

Endress + Hauser Proservo Model NMS80 Automatic Level Gauge Static Liquid Level Measuring System

submitted by Endress & Hauser Australia Pty Ltd
Level 1, 16 Giffnock Avenue
Macquarie Park NSW 2113

NOTE: This Certificate relates to the suitability of the pattern of the instrument for use for trade only in respect of its metrological characteristics. This Certificate does not constitute or imply any guarantee of compliance by the manufacturer or any other person with any requirements regarding safety.

This approval has been granted with reference to document NMI R 85-1 & 2, Automatic level gauges for measuring the level of liquid in fixed storage tanks, dated November 2012.

This approval is subject to review at the decision of the Chief Metrologist in accordance with the conditions specified in the document NMI P 106.

DOCUMENT HISTORY

Rev	Reason/Details	Date
0	Pattern provisionally approved – interim certificate issued	05/05/20
1	Pattern amended (Validity date and equivalent temperature transmitters) – interim certificate issued	06/01/22
2	Extended verification date– interim certificate issued	14/02/25

CONDITIONS OF APPROVAL

General

Instruments purporting to comply with this approval shall be marked with pattern approval number 'NMI P5/1/9' and only by persons authorised by the submitter. (Note: The 'P' in the approval number may be a temporary marking.)

It is the submitter's responsibility to ensure that all instruments marked with this approval number are constructed as described in the documentation lodged with the National Measurement Institute (NMI) and with the relevant Certificate of Approval and Technical Schedule. Failure to comply with this Condition may attract penalties under Section 19B of the National Measurement Act and may result in cancellation or withdrawal of the approval, in accordance with document NMI P 106.

Auxiliary devices used with this instrument shall comply with the requirements of General Supplementary Certificate No S1/0B.

Special Conditions of Approval: (Automatic Level Gauges)

Automatic Level Gauges measure automatically and display the level of liquid contained in a stationary (fixed) storage tank with respect to a fixed reference.

The Automatic Level Gauge shall only be installed on a stationary storage tank that has been designed and calibrated according to the General requirements of NMI Document R 71, Fixed Storage Tanks, dated February 2013.

The metrological purpose of tank level measurements is the application in conjunction with tank calibration tables for the determination of liquid volume received from, delivered to, or contained in stationary storage tanks.

Conversion of the liquid level to volume does not form part of the requirements of NMI Document R 85-1 & 2, as such the pattern has not been assessed for the correct operation of these functions. This Certificate does not constitute or imply approval for the conversion of liquid level to volume functions.

Where the liquid level measurement is converted to volume, the system must use appropriate tank calibration tables for the storage tank to which the Automatic Level Gauge is installed, alongside any other conversion factors applicable to the properties of the liquid being measured. Tank calibration tables must be determined from the calibration of a tank according to the method described in **clause 8.5** of NMI Document R 71, Fixed Storage Tanks, dated February 2013.

Where the liquid level measurement is converted to volume, and the volume is then converted to the measured volume at 15°C, the conversion is based on ASTM-IP-API Petroleum Measurement Tables 54A and 53A for Crude Oil, Tables 54B and 53B for Generalised Petroleum Products and Tables 54D and 53D for Lube Oils.

Special Conditions of Approval: (Test Procedure)

The properties of the fixed storage tank and product being measured by this Automatic Level Gauge may require a different test method to suitably verify the instrument after installation.

The test procedure of this approval requires the National Measurement Institute Australia to be provided with and authorise a procedure for verification of this Automatic Level Gauge **after** its installation on a fixed storage tank and prior to being verified for use for trade.

A procedure shall be provided to the NMI Pattern Approval laboratory. The details of the tank and the installation properties must also be provided, including details of the use of mounting supports, stilling pipes, guidance wires, datum plates, damping or deflector plates as applicable.

Special Conditions of Approval: (Provisional Approval)

This approval is limited to ten (10) instruments, the locations of which may be obtained from the National Measurement Institute. The submitter shall advise NMI in writing of the proposed location or serial number of each instrument prior to it being initially verified.

The approval will remain provisional pending completion of satisfactory testing and evaluation.

The submitter shall provide the NMI Pattern Approval Laboratory with copies of test results from the initial verification. In the event of unsatisfactory performance the approval may be cancelled (or altered).

The submitter shall implement such modifications as required by NMI. In the event that such modifications (if any are required by NMI) are not made to the satisfaction of NMI, this approval may be withdrawn.

Signed by a person authorised by the Chief Metrologist to exercise their powers under Regulation 60 of the *National Measurement Regulations 1999*.



Darryl Hines
Manager
Policy and Regulatory Services

TECHNICAL SCHEDULE No P5/1/9

1. Description of Pattern **provisionally approved on 05/05/20**
amended on 06/01/22

The pattern is an Endress+Hauser Proservo NMS80 Automatic Level Gauge measuring system for measuring the level of liquids in stationary storage tanks (Figure 1a).

1.1 Field of Operation

The field of operation of the measuring system is determined by the following characteristics:

- Maximum measuring range 40 m
- Ambient temperature range -40 to +70°C
- Liquid temperature range -200 to +200°C
- Liquid pressure range 0 to 2500 kPa
- Liquid density range see **1.5 Density Range**
- Power supply range 85 to 264 V AC or 19 to 63 V DC

1.2 Measuring Principle

The Proservo NMS80 Automatic Level Gauge measuring system uses a movable liquid level sensing element. A small displacer is placed on the liquid medium using a servo motor; the displacer is suspended on a measuring wire which is wound on finely-grooved drum housing within the instrument.

The length of wire extended by the servo motor along with the detection of the liquid surface allows the NMS80 level transmitter (Figure 2) to give information on its level.

1.3 System description

Systems may be with or without a stilling well (Figures 1b & 1c).

The system includes an Endress+Hauser Proservo model NMS80 servo level transmitter. The system may also include the following devices:

- Endress+Hauser Tank Side Monitor NRF81 level indicator (Figure 3)
 - DKX001 Tank Bottom Display (Figure 4)
 - Endress+Hauser Prothermo model NMT532/539 Multipoint Temperature transmitter (Figures 1 and 7), or an Endress+Hauser Prothermo NMT81 or equivalent (*) Temperature transmitter
 - Endress+Hauser Cerabar or equivalent (*) pressure transmitters
- (*) 'Equivalent' is defined to mean other proprietary equipment of the same or better specifications requiring no changes to software for satisfactory operation of the complete system.

1.4 Calculator/Indicator

The Proservo NMS80 servo level transmitter has a local LCD display for displaying information including height, temperature, density (#1) etc.

Repeating indication devices including an Endress+Hauser model NRF81 Tank Side Monitor (Figure 3) and/or Endress+Hauser model DKX001 Tank Bottom Display (Figure 4) may be fitted to the system.

Any other compatible (#2) NMI-approved calculator/indicator devices may also be used as repeating indicators.

(#1) The display of density is not for trade use.

(#2) 'Compatible' is defined to mean that no additions/changes to hardware/software are required for satisfactory operation of the complete system.

1.5 Density Range

For each displacer type the density range shall be determined using the following:

As the buoyancy of the displacer placed in liquid is a function of the density of the liquid (ρ) and the balance volume (V_B) of the displacer, for a given displacer and a set reference density (ρ_{ref}), a limited density range ($\rho_{min}; \rho_{max}$) applies. This density range depends on the given reference density, and therefore has to be calculated for this reference density as follows

1.5.1 Resulting weight of the displacer during balance, at reference condition:

$$m_{res} = m_{Disp} - \rho_{ref} * V_B$$

Balance volume may also be expressed as:

$$V_B = A_{Disp} * h_{ref} \Leftrightarrow h_{ref} = \frac{V_B * 4}{\pi * d_{Disp}^2}$$

Balance volume and reference density are adjustable parameters. The immersion depth (h_{ref}) of the displacer during balance can be calculated by the above stated formula using the displacers' cross-section (A_{Disp}) of the cylindrical part of the displacer.

1.5.2 Density range at a given reference density:

For each density the resulting weight of the displacer is equal since the algorithm calculates it out of the given parameters. So the minimum and maximum density may be calculated as follows:

$$\rho_{ref} * A_{Disp} * h_{ref} = (\rho_{ref} + \Delta\rho) * A_{Disp} * (h_{ref} \pm 1mm)$$

From this formula the minimum and maximum density can be determined as:

$$\rho_{min} = \frac{h_{ref}}{(h_{ref} + 1mm)} * \rho_{ref}$$

$$\rho_{max} = \frac{h_{ref}}{(h_{ref} - 1mm)} * \rho_{ref}$$

Symbol	Description
m_{res}	Resulting weight of the displacer when balanced in liquid [g]
m_{Disp}	Weight of displacer in air [g]
V_B	Balance volume (volume of displacer which is submerged in the liquid), stated on the displacers' label. [mL]
A_{Disp}	Cross-sectional area of displacer [mm ²]
d_{Disp}	Diameter of the cylindrical part of displacer
ρ_{ref}	Reference density, or density the user considers as reference (set value of the device, parameter "Upper density") [kg/m ³]
ρ_{min}	Minimum allowed density [kg/m ³]
ρ_{max}	Maximum allowed density [kg/m ³]
h_{ref}	Immersion depth of displacer [mm]

1.5.3 Balance volume of displacers:

The stated balance volume (V_B) on the displacer's label can be used to determine the density range as stated above. To increase the density range the following minimum balance volumes (V_{Bmin}) can be used alternatively. Using the listed h_{ref} values below the allowable density range can be calculated.

Displacer type	Balance volume V_B	V_B immersion depth h_{ref}	Minimum balance volume V_{Bmin}	V_{Bmin} immersion depth h_{ref}
50 mm SS / Al	70.7 mL	34.9 mm	35 mL	17.4 mm
50 mm PTFE	59.0 mL	30.0 mm	25 mL	12.5 mm
50 mm Alloy C	70.7 mL	34.9 mm	35 mL	17.4 mm
70 mm SS / Al	52.8 mL	13.7 mm	28 mL	7.2 mm
110 mm SS / Al	36.3 mL	3.8 mm	27 mL	2.8 mm

1.6 Inventory Management

The system may also be connected to the Endress+Hauser Tankvision inventory management devices, including Tankvision models NXA820 (Figure 5a), NX821, NXA822 and NXA83 (Figure 5b).

The Tankvision devices provide additional facilities including acquisition and summary of measurement data and parameters from multiple connected tank gauges.

The devices may also operate as repeating indication devices for connected measurement sensors

The devices may also transmit the measurement data to Tankvision Professional NXA85 and NXA86B Software (Figure 5c) operating on a PC-based device operating a Microsoft Windows based operating system. Indication of measurement results is presented in read-only mode on a personal computer screen.

The inventory management facilities shall not interact with the system in a way that would cause an incorrect indication of the measurement result of the NMS80 level transmitter.

1.7 System Architecture and Communication Protocol

The standard field communication protocol between Proservo NMS80 and the calculator/indicator is Modbus, V1 and/or HART (Figure 5a)

An Endress+Hauser Gauge Emulator GE (Figure 6) is an accessory which converts the signal of Proservo NMS80 and/or Tank Side Monitor to the required protocol: BPM, TRL/2 or WM550.

Endress+Hauser Wireless Hart Adapters and Gateways or Banner Modbus Industrial Wireless Radios can be used to transmit the data from the field devices to the repeating indicators (Figure 5b and 5c)

1.8 Verification Provision

Provision is made for the application of a verification mark.

1.9 Sealing Provision

Sealing provision for the Proservo NMS80 servo level transmitter is made by a sealing switch (Figure 8) after the system is configured and sealed with the switch closed. Sealing bolts and wires are also applied outside the gauge (Figures 9 and 10).

1.10 Descriptive Markings and Notices

Each measuring system shall bear the following information, placed together either on the indicating device or on a data plate:

Pattern approval number	NMI No P5/1/9
Manufacturer's identification mark or trade mark
Model number
Serial number
Year of manufacture
Minimum and maximum product density kg/m ³ (#1)
Liquid temperature range	... to ... °C (#2 & #3)
Liquid pressure range	... to ... kPa (#2 & #3)
Maximum height m (#3)
Minimum height m (#3)
Identification of the tanks

(#1) Only if this differs from a range of 600 kg/m³ to 1000 kg/m³

(#2) As specified by user for the application; otherwise as per clause **1.1 Field of Operation**.

(#3) Determined at verification after installation.

Connected repeating indicating devices shall be marked with the following information:

Pattern approval number	NMI No P5/1/9
Identification of the tanks

In addition, a notice "Only read when "Level Bal." is displayed" shall be visible on the data plate or any indicating device visible to the user during measurement.

2. Description of Variant 1 **approved on 05/05/20**

An Endress+Hauser model Proservo NMS81 Automatic Level Gauge measuring system which is similar to the pattern but uses a Proservo model NMS81 servo level transmitter (Figure 2b). The Proservo model NMS81 has a Stainless Steel transmitter and process housing.

3. Description of Variant 2 **approved on 05/05/20**

An Endress+Hauser model Proservo NMS83 Automatic Level Gauge measuring system which is similar to the pattern but uses a Proservo model NMS83 servo level transmitter (Figure 2c). The Proservo model NMS83 has an Aluminium transmitter housing and a Stainless Steel process housing for use with products having specific hygiene requirements such as food and beverages.

TEST PROCEDURE No P5/1/9

Instruments shall be tested in accordance with any relevant tests specified in the National Instrument Test Procedures.

The instrument shall not be adjusted to anything other than as close as practical to zero error, even when these values are within the maximum permissible errors.

Maximum Permissible Errors

The maximum permissible errors are as follows:

Prior to installation	1 mm
After Installation	4 mm

Tests

Prior to installation:

1. Before installation on the tank the instrument shall be checked for conformity with the approved type.
2. A calibration report for the instrument must be available and the verifier of the instrument shall review the results and confirm the instrument is within the required maximum permissible errors above.

The calibration report must include the *accuracy* test as described in clause 8.1.5.2 of NMI Document R 85-1. The calibration report must be carried out by a test facility with accreditation or certification to perform calibration of Automatic Level Gauges to the requirements of either NMI Document R 85-1 & 2 dated November 2012, or OIML R 85-1 & 2:2008.

3. Ensure instrument is sealed or the settings or properties of the instrument agree with those of the calibration report.

After Installation:

Prior to verification of each installation of an instrument, the National Measurement Institute Australia must be provided and authorise the use of a test procedure method to verify the Automatic Level Gauge after it is installed. See **Special Conditions of Approval: (Test Procedure)**

The verification procedure must also ensure the following:

1. For examination of installation and adjustment of the instrument on the tank, ensure that the requirements of clauses 7.1 to 7.3 of NMI Document R 85-1 are met.
2. Check the conditions of the tank match with the rated operating conditions specified in clause 6.1 of NMI Document R 85-1 and the rated operating conditions described in **1.1 Field of Operation** in the technical schedule of this approval.
3. Following the authorisation of a test procedure, ensure the instrument is within the required maximum permissible errors above.

FIGURE P5/1/9 – 1

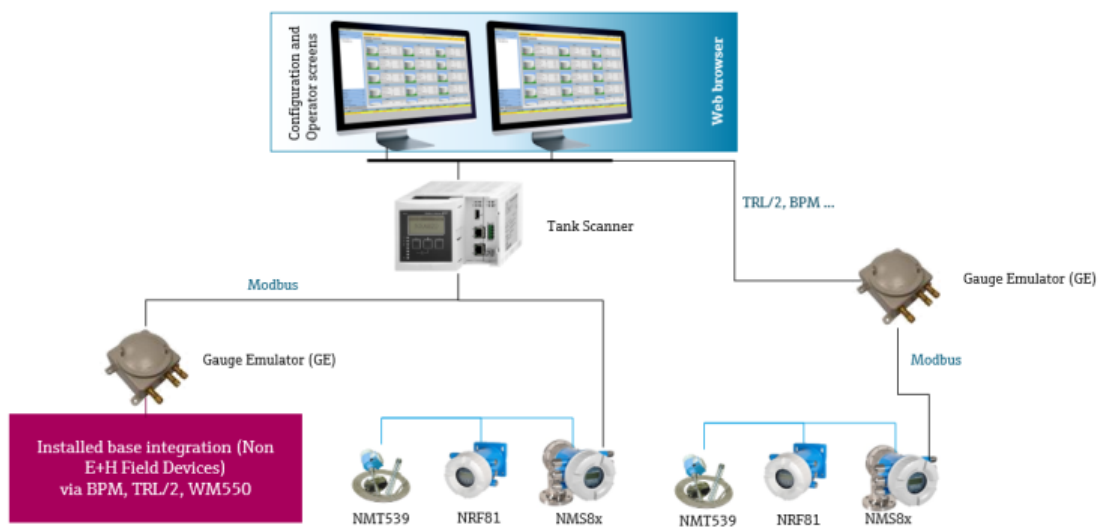

(a) Typical Proservo NMS80 System with Temperature Sensor and Indicator

NMS80

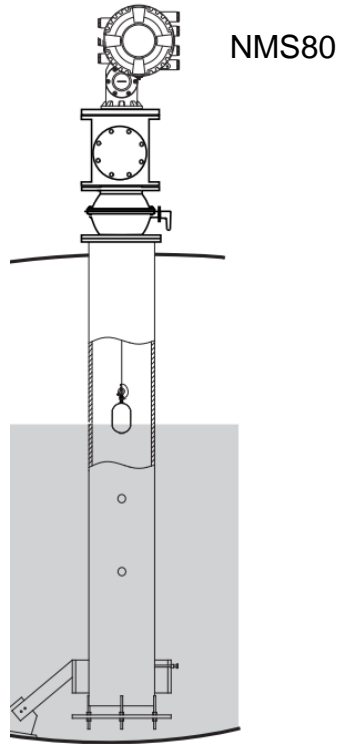

(b) With Stilling Well

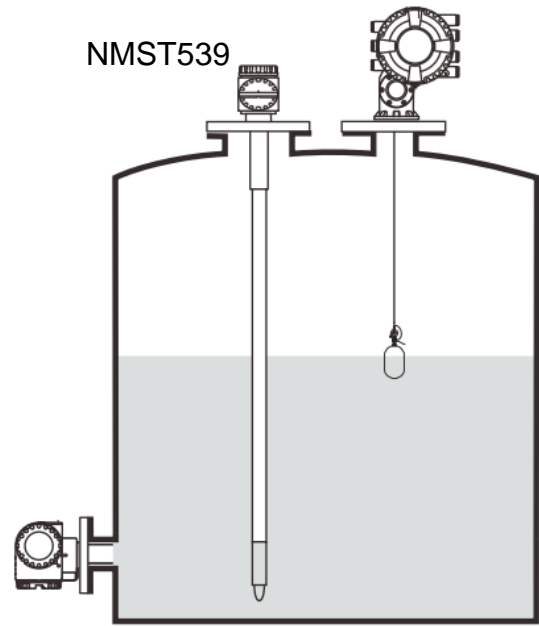

(c) Without Stilling Well

Endress + Hauser Proservo Model NMS80 Liquid Level Measuring System

FIGURE P5/1/9 – 2



(a) Endress+Hauser Proservo NMS80 Level Transmitter (Pattern)



(b) Endress+Hauser Proservo NMS81 Level Transmitter (Variant 1)



(c) Endress+Hauser Proservo NMS83 Level Transmitter (Variant 2)

FIGURE P5/1/9 – 3



Endress+Hauser Tank Side Monitor NRF81 LCD Liquid Level Indicating Device

FIGURE P5/1/9 – 4

Cast stainless

Alu



Endress+Hauser model DKX001 – Tank Bottom Display

FIGURE P5/1/9 – 5



(a) Endress+Hauser Tankvision Series NXA820 Calculator/Indicator



(b) Endress+Hauser Tankvision Series NXA83 Calculator/Indicator



(c) Endress+Hauser Tankvision Professional NXA85 and NXA86B software

FIGURE P5/1/9 – 5

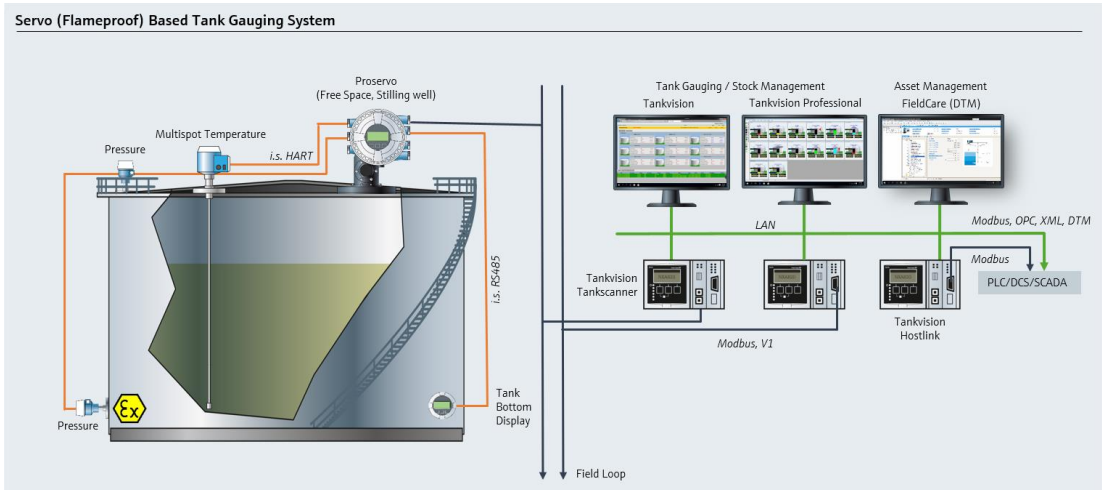

(a) Common NMS80 Tank Gauging System Architecture

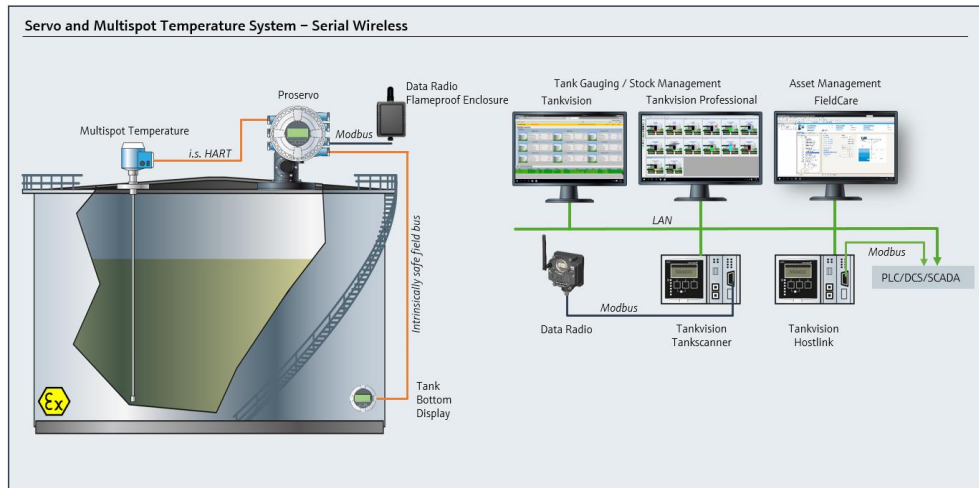

(b) Serial Wireless System Architecture

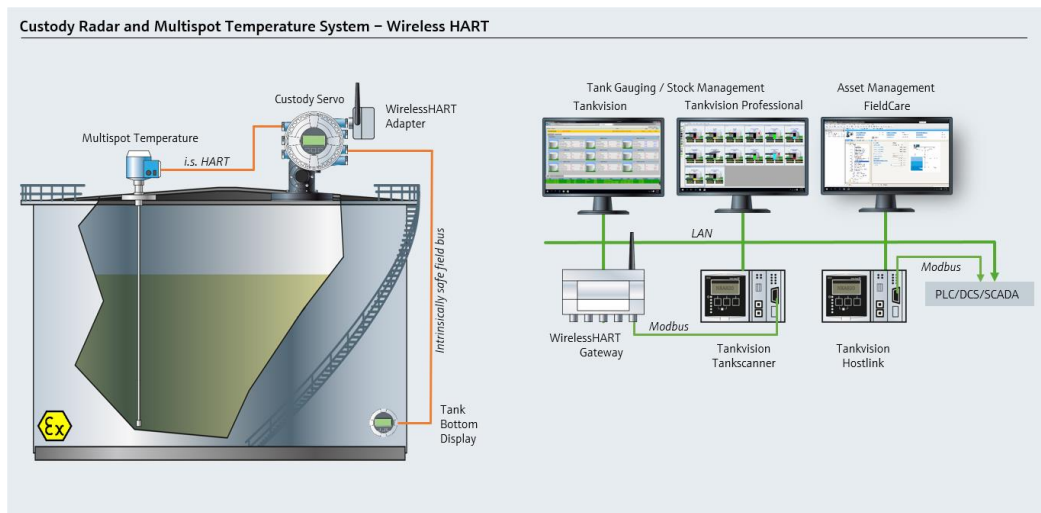

(c) Wireless Hart System Architecture

FIGURE P5/1/9 – 6



Edress+Hauser Gauge Emulator GE

FIGURE P5/1/9 – 7



Endress+Hauser Model NMT532/539 Temperature Probe and Transmitter

FIGURE P5/1/9 – 8

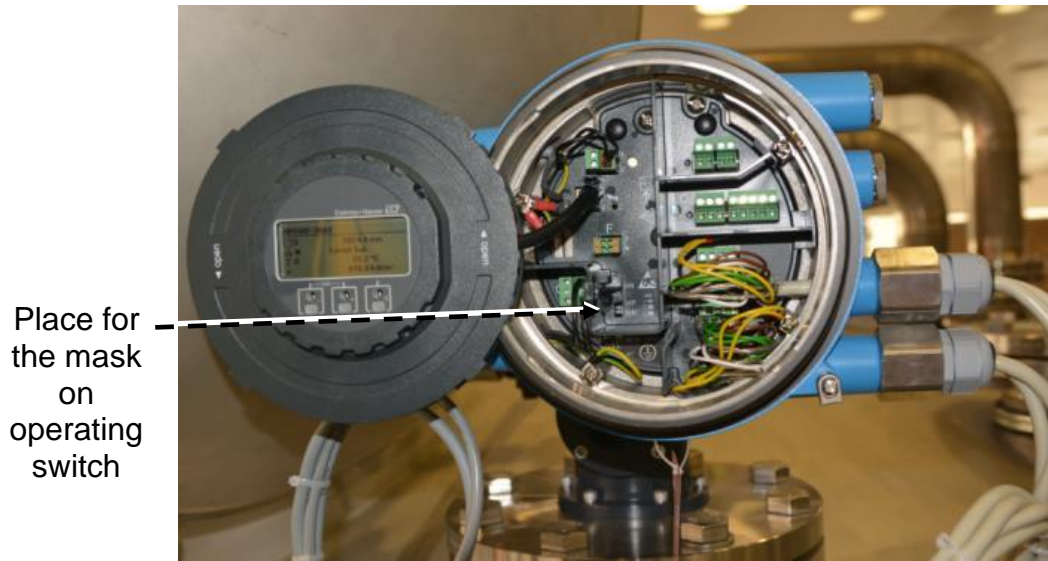

Typical Sealing of Operation Switch

FIGURE P5/1/9 – 9

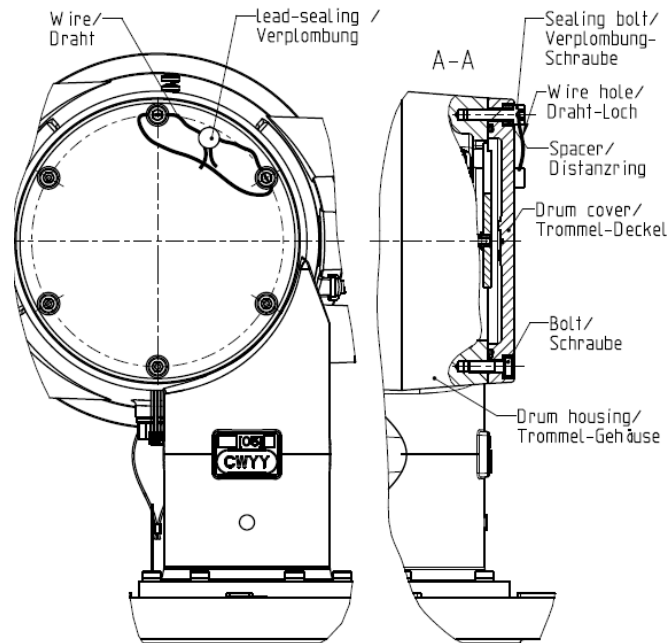

Sealing of wire drum compartment

FIGURE P5/1/9 – 10

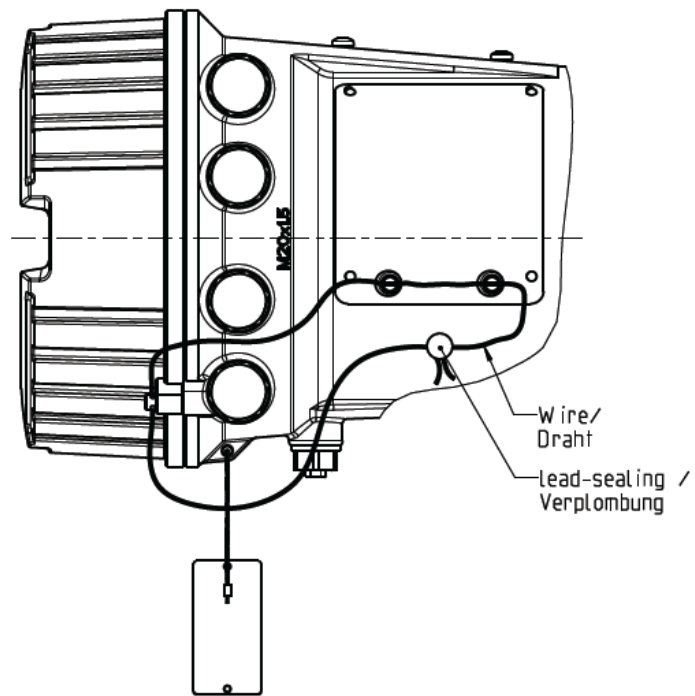

Sealing of main compartment and nameplate

~ End of Document ~