



Australian Government
Department of Industry and Science

National Measurement Institute

Certificate of Approval

NMI 5/6M/3

Issued by the Chief Metrologist under Regulation 60
of the
National Measurement Regulations 1999

This is to certify that an approval for use for trade has been granted in respect of the instruments herein described.

Gilbarco Model T923A8ND SK700-2 Fuel Dispenser for Motor Vehicles

submitted by Gilbarco Australia Limited
 20 Highgate Street
 AUBURN NSW 2144

NOTE: This Certificate relates to the suitability of the pattern of the instrument for use for trade only in respect of its metrological characteristics. This Certificate does not constitute or imply any guarantee of compliance by the manufacturer or any other person with any requirements regarding safety.

This approval has been granted with reference to document NMI R 117-1, Measuring Systems for Liquids Other than Water, dated July 2011.

This approval becomes subject to review on 1/12/20, and then every 5 years thereafter.

DOCUMENT HISTORY

Rev	Reason/Details	Date
0	Pattern & variants 1 to 8 approved – certificate issued	26/11/10
1	Pattern & variants 1 to 8 updated & amended (software version & Test Procedure) – certificate issued	13/02/13
2	Pattern & variants 1 to 8 reviewed & amended (density range) – certificate issued	24/08/15
3	Pattern & Variant 9 certificate issued	09/03/17

CONDITIONS OF APPROVAL

General

Instruments purporting to comply with this approval shall be marked with approval number 'NMI 5/6M/3' and only by persons authorised by the submitter.

It is the submitter's responsibility to ensure that all instruments marked with this approval number are constructed as described in the documentation lodged with the National Measurement Institute (NMI) and with the relevant Certificate of Approval and Technical Schedule. Failure to comply with this Condition may attract penalties under Section 19B of the National Measurement Act and may result in cancellation or withdrawal of the approval, in accordance with document NMI P 106.

Auxiliary devices used with this instrument shall comply with the requirements of General Supplementary Certificates No S1/0/A or No S1/0B.

Signed by a person authorised by the Chief Metrologist
to exercise their powers under Regulation 60 of the
National Measurement Regulations 1999.

Signed

Stephen Horrocks

TECHNICAL SCHEDULE No 5/6M/3

1. Description of Pattern **approved on 26/11/10**

A Gilbarco model T923A8ND SK700-2 fuel dispenser (Figures 1 and 2) for motor vehicles is approved to dispense LPG and various grades of liquid fuels, in attendant-operated mode, or in attended self-service mode using any compatible (#) approved control console. The meter is adjusted to be correct for the liquid for which it is to be verified. The pattern includes Batchen model MkIII meters for LPG and Gilbarco model C+ meters for other fuels.

(#) 'Compatible' is defined to mean that no additions/changes to hardware/software are required for satisfactory operation of the complete system.

1.1 Field of Operation

The field of operation of the measuring system is determined by the following characteristics:

Characteristics common to all systems

- Minimum measured quantity, V_{min} 2 L
- Ambient temperature range -25 to 55°C

Characteristics specific to LPG metering

- Maximum flow rate, Q_{max} 40 L/min
- Minimum flow rate, Q_{min} 8 L/min
- Maximum pressure of the liquid, P_{max} 2450 kPa
- LPG density detection range (at 15°C) 500 kg/m³ to 590 kg/m³
- Volume conversion to 15°C over a liquid temperature range of -5°C to 45°C
- Operating pressure is maintained at least 200 kPa above the equilibrium vapour pressure of LPG.
- Accuracy class 1.0

Characteristics specific to petrol/diesel metering

- Maximum flow rate, Q_{max} 50 L/min
- Minimum flow rate, Q_{min} 5 L/min
- Maximum pressure of the liquid, P_{max} 350 kPa
- Minimum pressure of the liquid, P_{min} 140 kPa (#1)
- Range of liquids viscosity (at 20°C) 0.5 to 20 mPa.s (#2)
- Maximum temperature of the liquid, T_{max} 50°C
- Minimum temperature of the liquid, T_{min} -10°C
- Accuracy class 0.5

(#1) Minimum pressure required for effective operation of the gas elimination device.

(#2) The flowmeter is adjusted for use with one product viscosity. Fuels include kerosene, distillate and various grades of petrol (which may include up to 10% ethanol, E10). The pattern and variants constructed for use to dispense various grades of pure biodiesel and biodiesel/distillate blends (to Australian government standard).

1.2 Description of the Metering Systems

The Gilbarco model T923A8ND SK700-2 dispenser (Figures 1 and 2) includes the following components or features:

- A Batchen model Mk-V constant bleed vapour elimination device.
 - Two Batchen model Mk VI spring-loaded pressure differential valves.
 - Two Batchen model MkIII two-piston liquefied petroleum gas (LPG) flowmeters each fitted with a Gilbarco model 510 pulse generator for LPG.
 - With an optional magnetic coupling between the meter and the pulse generator.
 - A Gilbarco model Sandpiper 2 (aka model E101) calculator/indicator configured for use with a density detection device enabling the volume conversion to 15°C for LPG.
 - With an optional pre-setting device.
 - Two Gasguard model LGI LPG or any other NMI-approved LPG nozzles (*).
 - Pressure inputs for petrol and diesel grades supplied by remote submersible turbine pumps (STPs).
 - Six measurement transducers each comprising a Gilbarco model C+ four piston positive displacement flowmeter fitted with an SK700-2 model Encore 510 pulse generator.
 - A pre-set facility for volume or price.
 - Six 16 mm ZVA Elaflex or ZVA 2 Elaflex nozzle or any other NMI-approved nozzle (*).
- (*). Note that the submitter must be consulted regarding the acceptability of any alternative nozzles.

A compatible NMI-approved control system may also be connected to provide self-service operation.

1.3 System Description for LPG (Figure 3)

- (i) The supply tank may be located above or below ground depending on the type of pump used.
- (ii) The pump may be positioned above the supply tank, in which case the pump shall be a multi-stage regenerative turbine LPG pump specially designed for use in **suction lift** installations. Alternatively, the pump shall be positioned below the supply tank or a submersible turbine pump (STP) may be located within the supply tank so that it is always in a state of flooded suction (**suction head** installations). There shall be no restrictive fittings within ten pipe diameters of the pump inlet.

The inlet pipe to the pump is larger than the outlet pipe from the pump. The external pump by-pass relief valve is installed in a line returning to the vapour space of the supply tank.

A pump supplying LPG to several flowmeters shall be of sufficient capacity rating to ensure that when all flowmeters are in use the flow rate through each flowmeter is greater than Q_{min} .

- (iii) The LPG flowmeters are protected from the measurement of vapour by a Batchen model Mk-V vapour eliminator (Figure 4a) and an LPG Measurement model DSSG98 LPG or model DSSG-2000 monitoring device.
The gas elimination device allows a continuous bleeding of LPG and any vapour back to the vapour space of the supply tank, via a vapour return line of not less than 20 mm in diameter.
In addition, a vapour detection sensor is incorporated which activates the flow control valve to stop the measurement when an excessive amount of vapour is detected.
The gas elimination device also has provision for inserting a reference thermometer for verification of LPG temperature measurement.
- (iv) The measurement transducers are two Batchen model Mk III two piston positive displacement LPG flowmeters (Figure 4b) each fitted with a Gilbarco model Encore 510 dual channel pulse generator. The shaft of the meter and the pulse generator rotate twice for a throughput of one litre. The pulse generator incorporates gears to produce, in conjunction with the software of the calculator/indicator, a pulse output of 250 pulses/litre. The outlet of the meter is connected to a flow control valve with an optional pre-set valve. The flowmeter is suitable for use over a flow rate range of 8 to 50 L/min, but the dispenser is only approved for use up to a maximum of 40 L/min.
- (vii) The transfer device is a Gasguard model LGI LPG nozzle, or any other compatible NMI-approved LPG nozzle (*) that cannot be placed in a hung-up position other than to end the delivery. The nozzle is connected to a DAYCO model 7132 CGA hose, or any other compatible hose complying with the relevant standards for LPG. A breakaway coupling and an excess flow valve may be fitted to the hose.
- (viii) A non-resettable electro-mechanical volume totaliser is provided for each hose or each grade. The totaliser indicates the accumulative volume at 15°C dispensed by the instrument. The totaliser is located adjacent to the Management Interface Unit.

An optional 'dead man' switch may be fitted to the LPG system. Refer to Variant 2.

1.4 System Description For Petrol/Diesel

The pattern incorporates the following components:

- (i) External compatible submersible turbine pumps (STPs) each incorporating a leak detector system (Figure 5). The pattern (model T923A8ND SK700-2) operates with standard (Normal) flow rate, Q_{max} of up to 50 L/min.
- (ii) Six measurement transducers each comprising a Gilbarco model C+ four piston positive displacement flowmeter (Figure 6) fitted with an SK700 model Encore 510 pulse generator. The meter may also known as the model T19976 G3, which may also have an 'S' suffix.
- (iii) Six 16 mm ZVA Elaflex or ZVA 2 Elaflex nozzles or any other NMI-approved nozzles (*).
- (*) Note that the submitter must be consulted regarding the acceptability of any alternative nozzles.

1.5 Calculator/Indicator

A Gilbarco model Sandpiper 2 calculator/indicator (also known as the model E101 – Figure 7) which has a single display for indicating volume and another for price. There is also a unit price display for each hose (Figure 1); an emergency stop may be provided in the vicinity of the indicating head. The instrument is approved with versions 25xxx, 27xxx or 29xxx (*) software, which can be viewed by at power up or by forcing a restart by pushing the F1 then the F2 buttons on the Managers' keypad.

The display limits and increments are:

Price	9999, 99 in 0.01 \$ increments
Volume	9999, 99 in 0.01 L increments
Unit price	999, 9 in 0.1 ¢/L increments
Totaliser	9999999 L

A pre-set device may also be fitted to allow pre-set to be selected by means of volume (litres) or price (dollars).

During pressurisation the instrument suppresses the display for the first 100 mL of the delivery.

The calculator/indicator also incorporates a checking facility for the meter pulse output, density/temperature measurement and vapour detection devices.

A non-resettable electro-mechanical volume totaliser is provided for each hose or each grade.

1.6 Volume Conversion for Density and Temperature Device for LPG

The volume conversion for density and temperature function is performed by the calculator indicator in conjunction with the LPG Measurement model DSSG98 LPG or model DSSG-2000 monitoring device. The device comprises a probe located in the vapour eliminator interfaced to an integrated circuit board located in a separate unit (model DSSG98 only). The probe senses LPG density, measures the temperature of the LPG, and detects if any vapour is present. The monitoring device incorporates the ASTM-IP-API *Petroleum Measurement Tables for Light Hydrocarbon Liquids*, metric edition, Table 54 and Table 53 for volume conversion within the approved field of operation.

1.7 Operation and Checking Facilities

Removing the nozzle from its receptacle starts the operating cycle of the instrument. The reset cycle clears the display of any previous sale and starts the pump. The instrument will automatically check for meter pulse output and for correct parameter settings. A segment check is also performed and when completed the unit price is displayed and the price and volume displays are reset to zero. At the end of this cycle, the solenoid valve opens and the delivery can start. Replacing the nozzle to its normal hang up position closes the solenoid valve and the delivery is terminated. The details of the delivery are displayed by the instrument until the next reset cycle.

An automatic segment test is performed at the start of each delivery.

The calculator monitors the presence and correct transmission of signal from the measurement transducer, and in the event of detecting a fault the instrument indicates an error code and has provision for controlling electrically-operated valves to stop the delivery.

1.8 Descriptive Markings and Notices

- (a) Instruments are marked with the following data, together in one location on a data plate:

Pattern approval sign	NMI 5/6M/3
Manufacturer's identification mark or trade mark
Manufacturer's designation (model number)
Serial number
Year of manufacture
Environmental class	class C

For LPG

Maximum flow rate (Q_{max}) L/min
Minimum flow rate (Q_{min}) L/min
Maximum operating pressure (P_{max})	2450 kPa
Approved for LPG density range	500 kg/m ³ to 590 kg/m ³ (at 15°C)
Maximum liquid temperature (T_{max})	45°C
Minimum liquid temperature (T_{min})	-5°C
Accuracy class	class 1.0

For Petrol/Diesel

Maximum flow rate (Q_{max}) L/min
Minimum flow rate (Q_{min}) L/min
Maximum operating pressure (P_{max}) kPa
Minimum operating pressure (P_{min}) kPa
Nature of liquids to be measured (#)
Accuracy class	class 0.5

(#) e.g. distillate or D.

- (b) The minimum measured quantity (V_{min}) shall be clearly visible on any indicating device visible to the user during measurement, in the form 'Minimum delivery 2 L'.

1.9 Verification Provision

Provision is made for the application of a verification mark.

1.10 Sealing Provision

Provision is made for sealing the mechanical calibration device of the meters.

For LPG

The meter has provision for sealing as shown in Figure 4b. Access to the electronic calibration button and switches to select individual meters have provision for sealing (Figure 8).

For Petrol/Diesel

The suction pump gas separator test valve has provision for sealing (Figure 9).

2. Description of Variant 1 **approved on 26/11/10**

Certain other models and configurations of the T92*A*** SK700-2 series of fuel dispensers, where *** represents the number of hoses/nozzles, the flowrate (Normal, High, Extended or Ultra-high) and the hydraulic module type (Dispenser supplied by an external submersible turbine pump (STP) system, or internal Pump) respectively, e.g. the pattern (model T923A8NP is an 8 hose, 'Normal' flow rate (50 L/min) Dispenser supplied by an STP system, having 2 hoses for LPG and 6 for petrol/diesel.

Dispensers for use with distillate may also be used with a High flow rate, Q_{max} of up to 90 L/min or an Ultra-high flow rate, Q_{max} of up to 160 L/min.

Instruments may be with (T923A...) or without (T927A...) hose retraction.

3. Description of Variant 2 **approved on 26/11/10**

With a 'dead man' switch fitted to the LPG system.

The 'dead man' switch controls the opening of the flow control valve during filling.

When this switch is fitted, the solenoid valve will open at the end of the reset cycle (as described in testing procedure for commencement of a delivery) and then the 'dead man' switch is held closed to allow a delivery to proceed. Releasing the switch will stop the delivery.

4. Description of Variant 3 **approved on 26/11/10**

With one or more Gilbarco model Eco screw type flowmeters (Figure 10) instead of the model C+ flowmeters described for the pattern. This meter is fitted with an Eltomatic model ME 01 04 pulse generator.

5. Description of Variant 4 **approved on 26/11/10**

With the STP hydraulic system replaced by one or more Gilbarco model GPU-90 pumping units (Figure 11) with self-contained air separation system as described in the documentation of approval NMI S455 for the petrol/diesel (non LPG) grades. Hoses per grade may operate with the standard maximum flow rate, Q_{max} of up to 50 L/min, or if used with distillate may be used up to a maximum flow rate, Q_{max} of up to 160 L/min. Refer also to variants 5, 6 and 7.

These units have model numbers with a 'P' replacing the 'D', e.g. T923A**P.

6. Description of Variant 5 **approved on 26/11/10**

With Gilbarco model GPU-90 petrol/diesel pumping units with 32 mm piping, 32 mm hoses, and ZVA Elaflex 32 mm nozzles (*), and known as High flow rate fuel dispensers with the following field of operation:

- For use with distillate
- Maximum flow rate (Q_{max}) 90 L/min
- Minimum flow rate (Q_{min}) 9 L/min
- Minimum measured quantity (V_{min}) 5 L

7. Description of Variant 6 **approved on 26/11/10**

With Gilbarco model GPU-140 petrol/diesel pumping units with 32 mm piping, 32 mm hoses, and ZVA Elaflex 32 mm nozzles (*), and known as **Extended flow rate fuel dispensers** with the following field of operation:

- For use with distillate
- Maximum flow rate (Q_{max}) 130 L/min
- Minimum flow rate (Q_{min}) 13 L/min
- Minimum measured quantity (V_{min}) 5 L

8. Description of Variant 7 **approved on 26/11/10**

With two Gilbarco model GPU-90 petrol/diesel pumping units in parallel, with 32 mm piping, 32 mm hoses, and ZVA Elaflex 32 mm nozzles (*), and known as **Ultra-high flow rate fuel dispensers** with the following field of operation:

- For use with distillate
- Maximum flow rate (Q_{max}) 160 L/min
- Minimum flow rate (Q_{min}) 16 L/min
- Minimum measured quantity (V_{min}) 5 L

(*) Note that the submitter must be consulted regarding the acceptability of any alternative nozzles.

9. Description of Variant 8 **approved on 26/11/10**

Instruments are fitted with a Gilbarco Stage 2 (VR2) vapour recovery and monitoring system and are used up to a maximum flow rate of 42 L/min. The vapour recovery components of a typical instrument are shown in Figure 12.

The vapour recovery and monitoring system is approved by the German TÜV SÜD Industrie Service GmbH authority.

Only vapour recovery components and systems as listed below and included in the relevant TÜV approval certificates may be used. The relevant TÜV approvals (and the approved components) are:

- (i) For collection of vapour:
 - TÜV 85-2.128 (electric valves); or
 - TÜV TÜV 85-2.160 (manual valves),and the only approved system components are:
 - Vapour recovery nozzles – Elaflex models ZVA 200 GR, ZVA SLIMLINE 2 GR, or ZVA SLIMLINE 2 GRVP.
 - Coaxial hose – Elaflex model Conti Slimline 21/8 Coax.
 - Control valves – Burkert model 6022 / 2832.
 - Control board – Gilbarco model VRC 390/x or VRB (#).
 - Vapour recovery pump(s) – Durr models MEX 0831-10, MEX 0831-11, or MEX 0544.
 - (ii) For automatic monitoring of the vapour to fuel ratio:
 - TÜV UE-12.5,and the only approved system components are:
 - Gilbarco (GVR) model VMC monitor or VRB (#).
 - Gilbarco (GVR) model GE1 flowmeter.
- (#) The VRB ('vapour recovery board') combines the functions of the separate VRC and VMC units into a single printed circuit board.

10. Description of Variant 9

approved on 09/03/17

For use with Gilbarco Apollo calculator/indicator

TEST PROCEDURE No 5/6M/3

Instruments shall be tested in accordance with any relevant tests specified in the National Instrument Test Procedures.

Tests should be conducted in conjunction with any tests specified in the approval documentation for any components used, including indicator/controller and submersible turbine pump (STP) hydraulic systems.

The instrument shall not be adjusted to anything other than as close as practical to zero error, even when these values are within the maximum permissible errors.

Maximum Permissible Errors

The maximum permissible errors are specified in Schedule 1 of the *National Trade Measurement Regulations 2009*.

Tests

For LPG

To display the temperature, density and volume at operating conditions, via the Manager's keypad:

1. Push F1.
2. Push digits 2, 2, 2, 2, then ENTER (*).
3. Push 3, and then ENTER.
4. Push 1, then ENTER for uncompensated Volume (or 2 for compensated).
5. Push digit to select required LPG meter, then ENTER.

Note: Push 'Clear' if different selection required before pushing ENTER.

Refer Figure 13 for meter position and required selection digits.
e.g. For meter A select 1, for meter E select 5.

Push F1, to prompt to select alternative meters or volume options.

Push F2, to reboot and exit.

(*) '2222' is default access code for level 1 programming; if code has been changed, check with site manager for current access code.

Display format of 'W & M' (trade measurement) data:

PPU			T	T	t	LPG grade PPU = Temperature (e.g. 25.3 deg C)
\$				D	D	\$ display = Density setting from probe (e.g. .53 for 530 kg/m ³)
VOL		V	V	V	v	Vol display = Uncompensated or compensated Vol (last delivery)

Other applicable maximum permissible errors are:

±0.5°C for the temperature measuring device;

±10 kg/m³ for the density detection device;

±40 mL for deliveries equal to the minimum measured quantity; and

±1.0% for gas elimination for LPG.

Details on the calibration procedure may be found in the Gilbarco SK700-2 LPG service manual.

FIGURE 5/6M/3 – 1

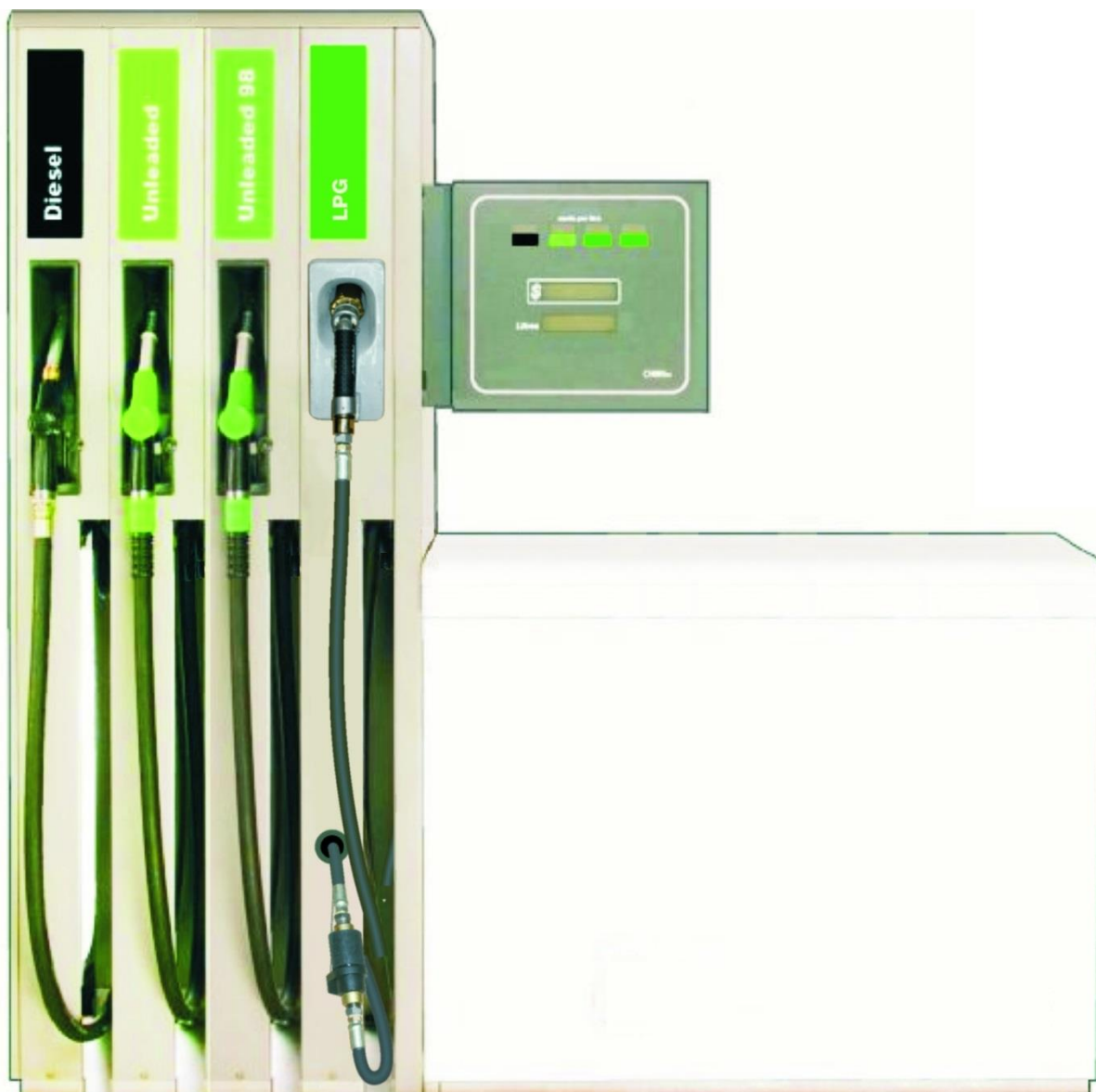

Gilbarco Model T923A8ND SK700-2 Fuel Dispenser for Motor Vehicles

FIGURE 5/6M/3 – 2

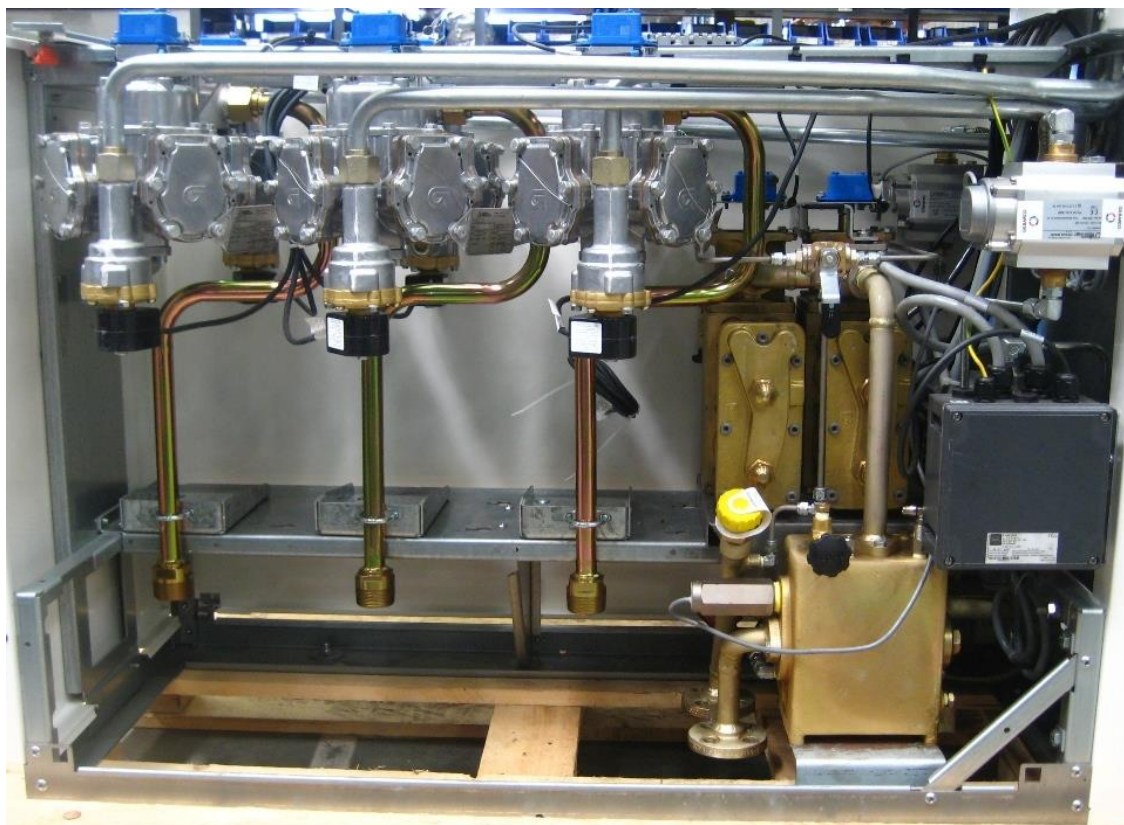

Gilbarco Model T923A8ND SK700-2 Fuel Dispenser – Hydraulic Cabinet
(3 x Petrol/Diesel modules, vapour eliminator and 2 x LPG meters, and
VR -2 module for 2 sides)

FIGURE 5/6M/3 - 3

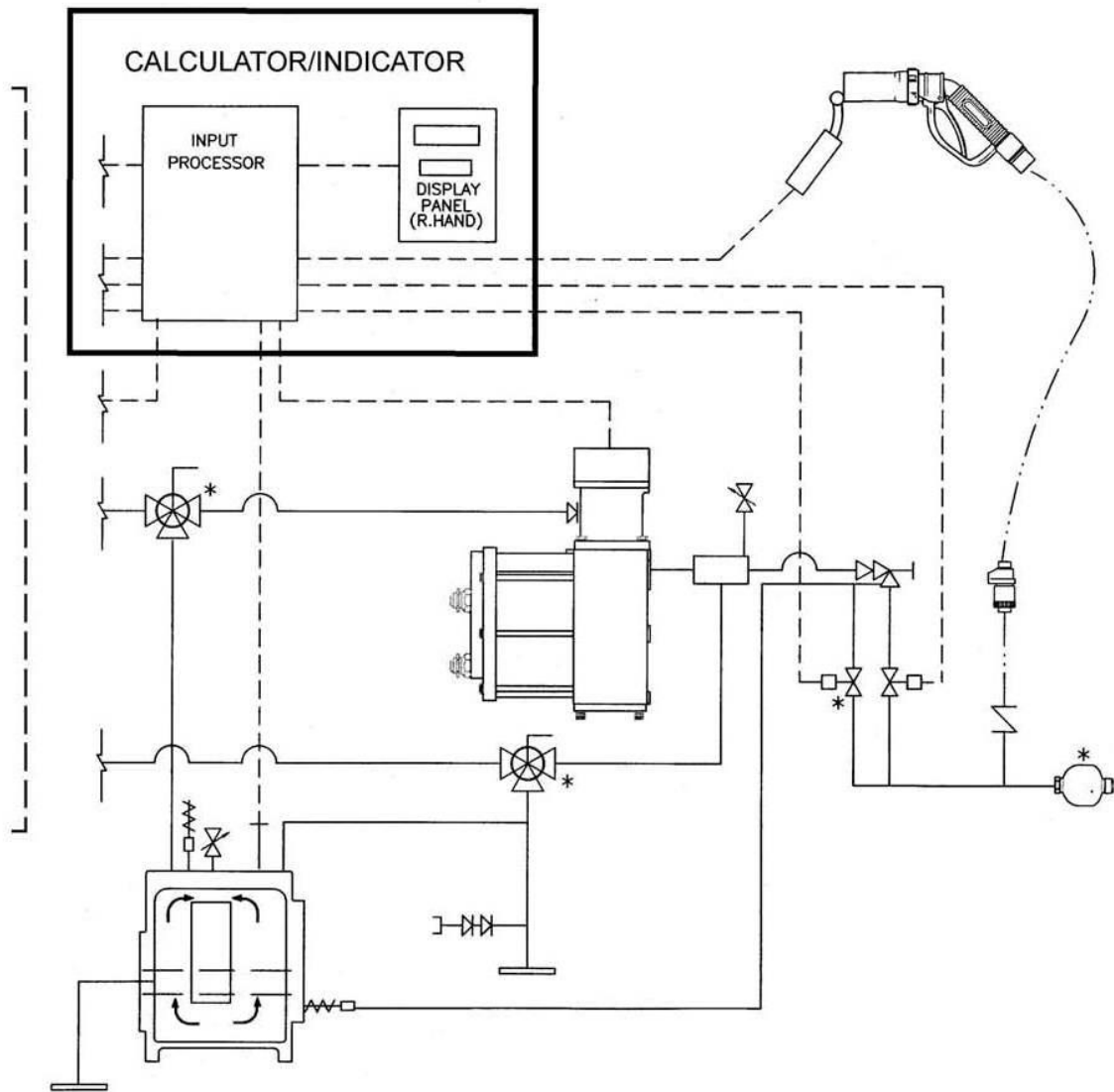

* OPTIONAL ITEMS -

Typical LPG System Hydraulics Batchen Model Mk III LPG Flowmeter
(Single system shown for clarity)

FIGURE 5/6M/3 – 4



(a) Batchen Model Vapour Mk V Eliminator



(b) Batchen Model Mk III LPG Flowmeter (including sealing)

FIGURE 5/6M/3 – 5

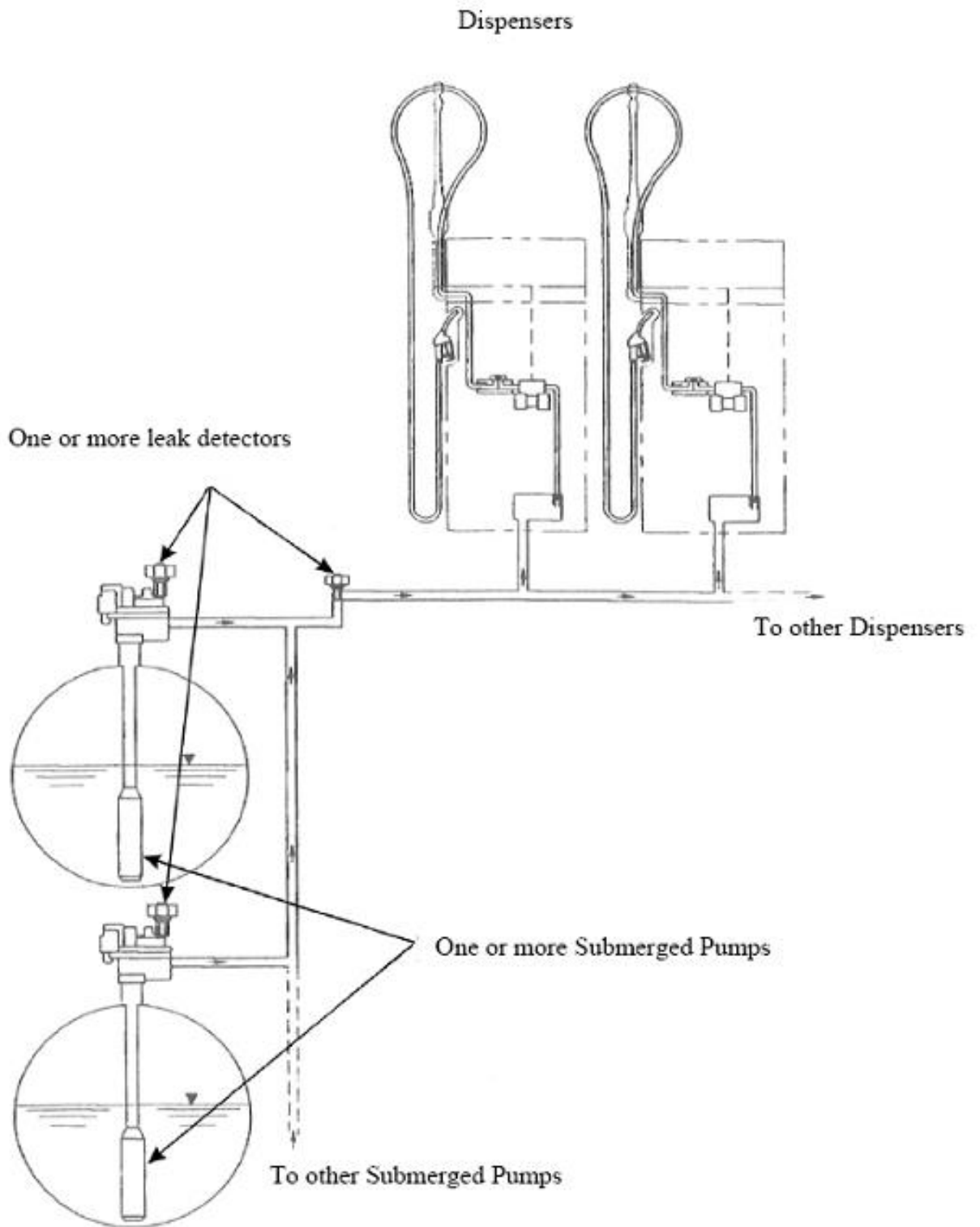

Typical Submersible Turbine Pump (STPs) System

FIGURE 5/6M/3 – 6

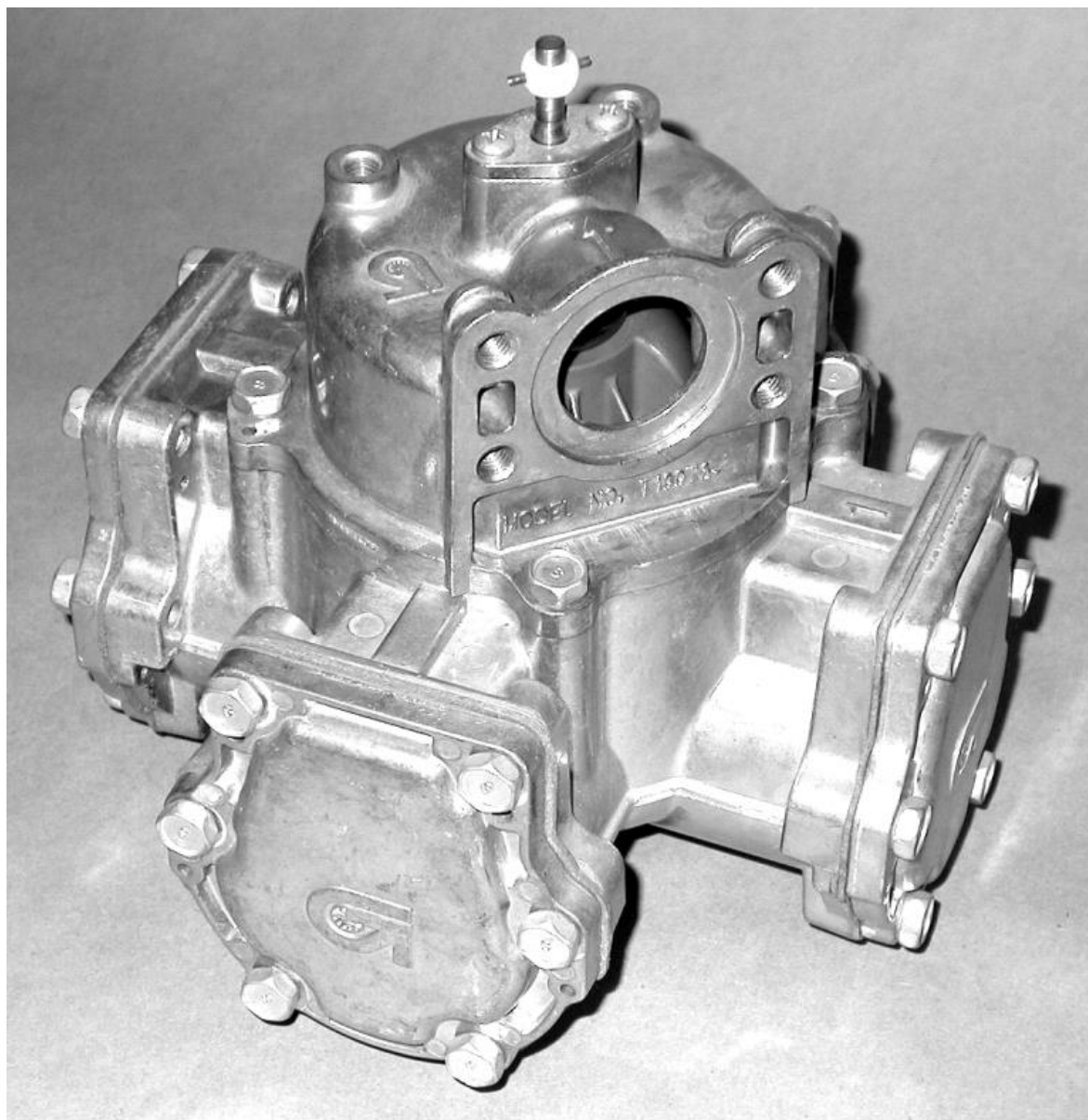

A Gilbarco Model C+ Flowmeter (aka Model T19976 G3) – Petrol & Diesel

FIGURE 5/6M/3 – 7

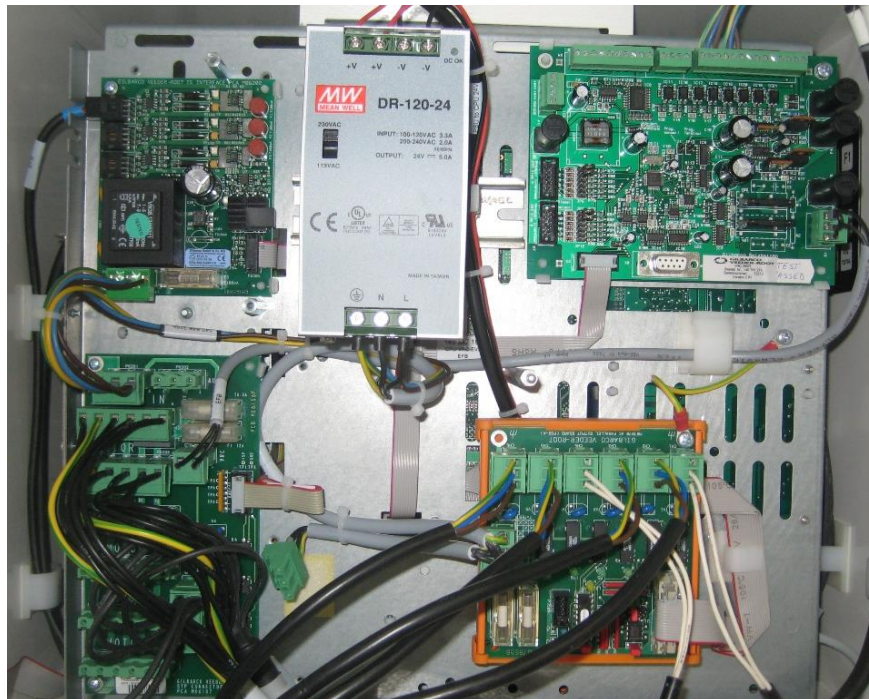

Power Supply and Driver Printed Circuit Boards

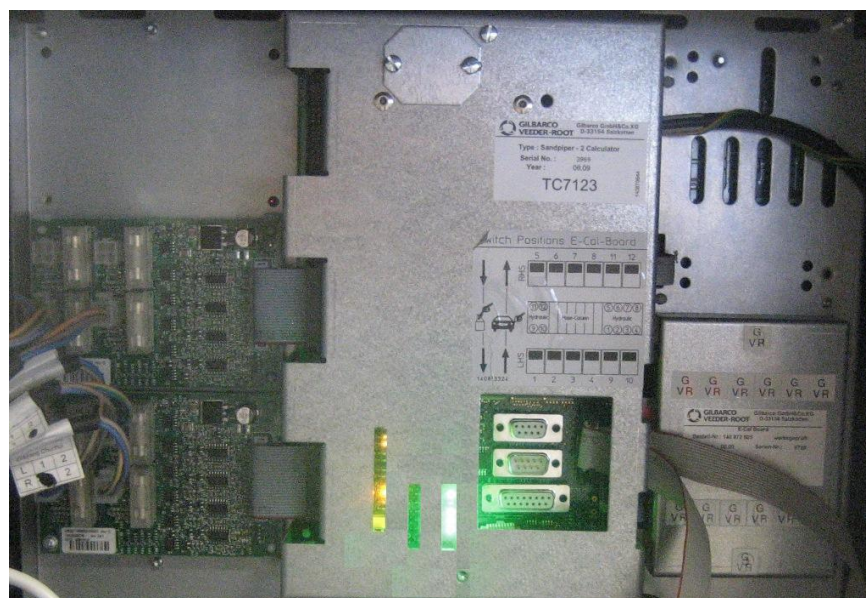

Processor PCB and Interface Cards

Sandpiper 2 Calculator/Indicator (aka Model E101) Electronics
Typical Mounting Arrangement

FIGURE 5/6M/3 – 8

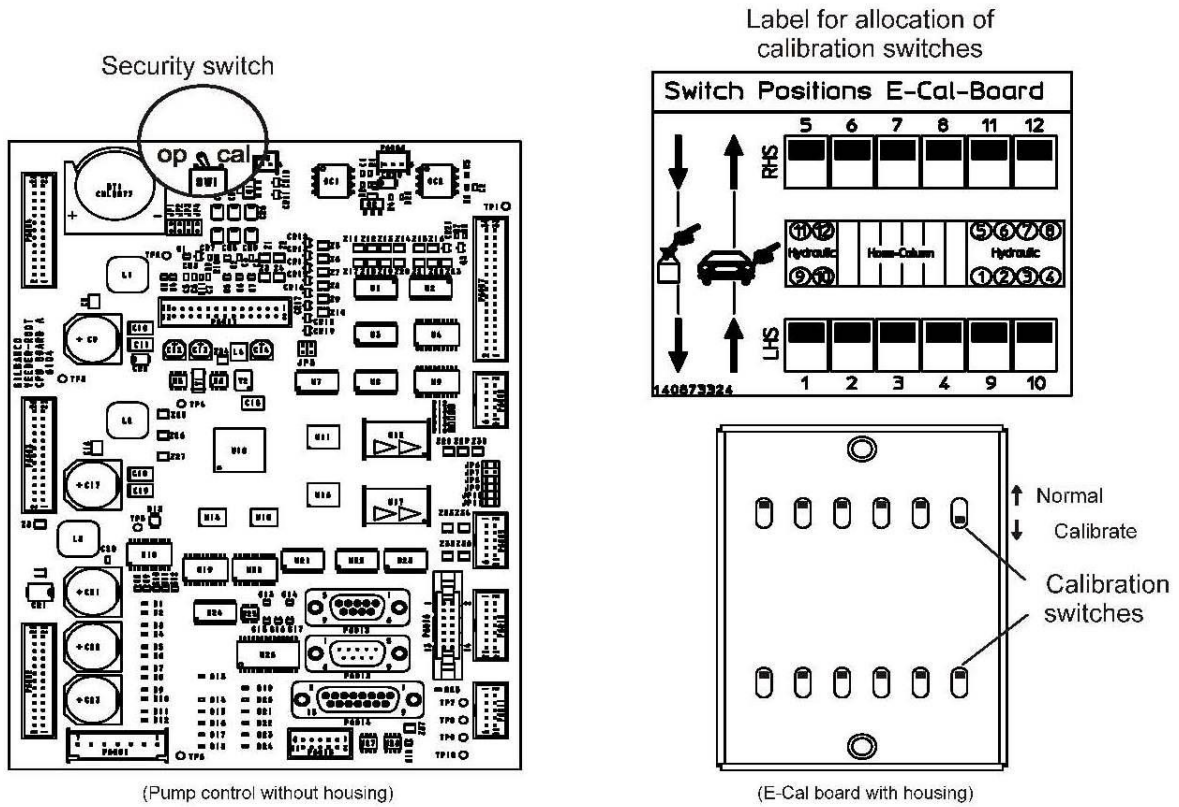

(a) Electronics Sealing – Sealing of Petrol/Diesel/LPG Meter Calibration Access (destructible adhesive labels used for security and calibration switches)

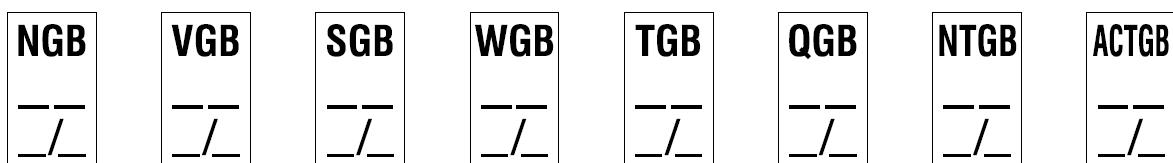

(b) Examples of different seal details

FIGURE 5/6M/3 – 9

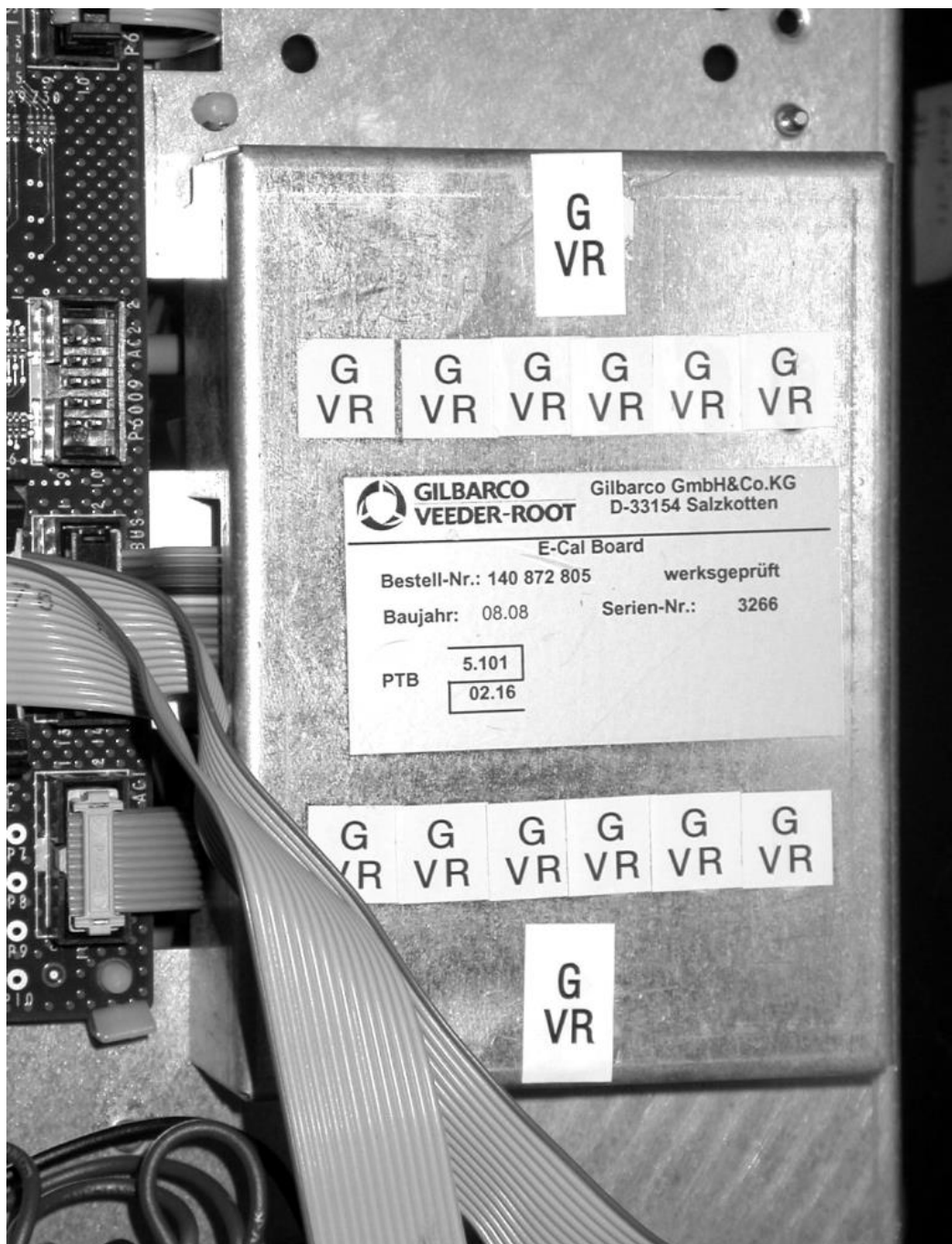

Typical Sealing of Petrol/Diesel Meter Calibration Access
(using destructible adhesive labels)

FIGURE 5/6M/3 – 10

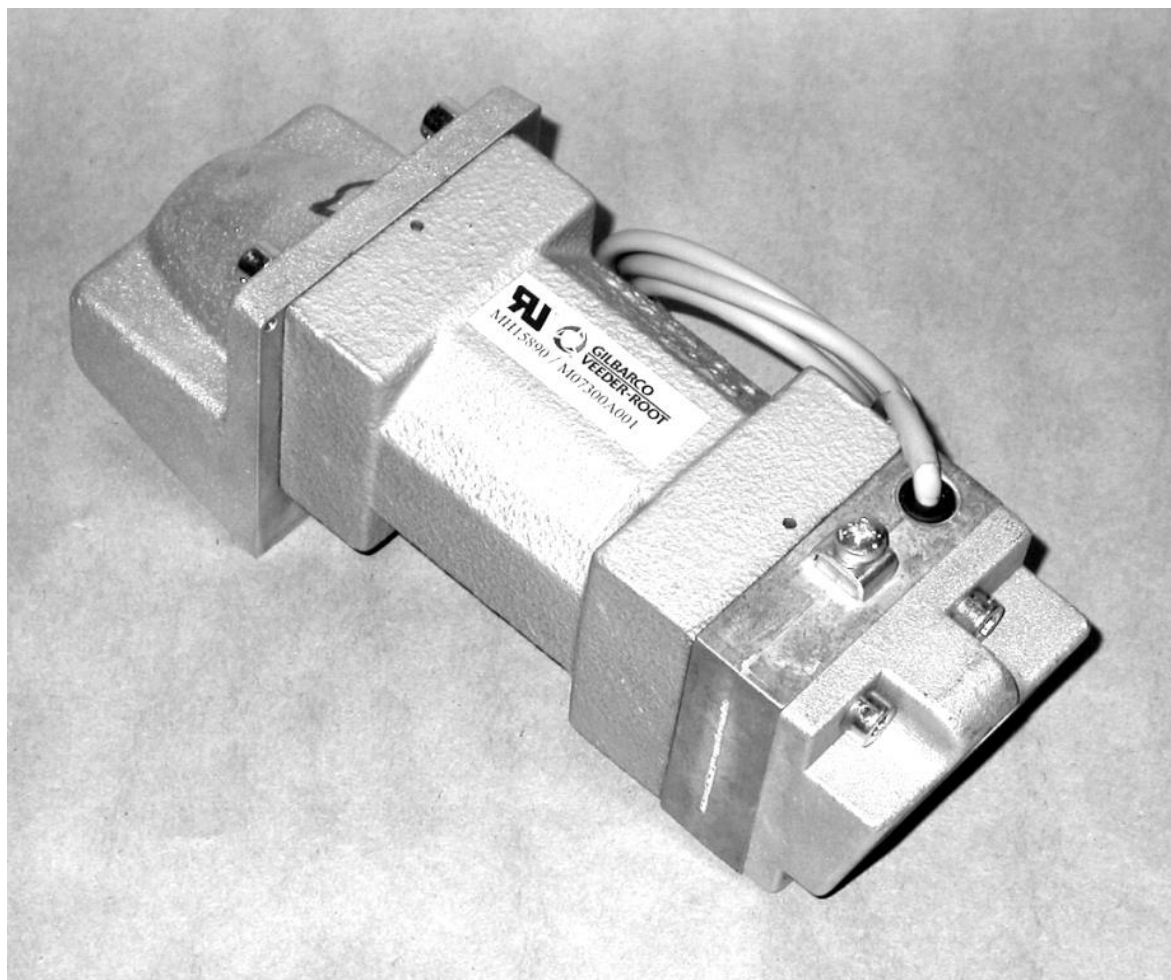

Gilbarco Model Eco Flowmeter – Petrol & Diesel

FIGURE 5/6M/3 – 11



Gilbarco Model GPU-90 Pumping Unit (without inlet filter bowl)



Gilbarco Model GPU-90 Pumping Unit (rear view with inlet filter bowl)

FIGURE 5/6M/3 – 12

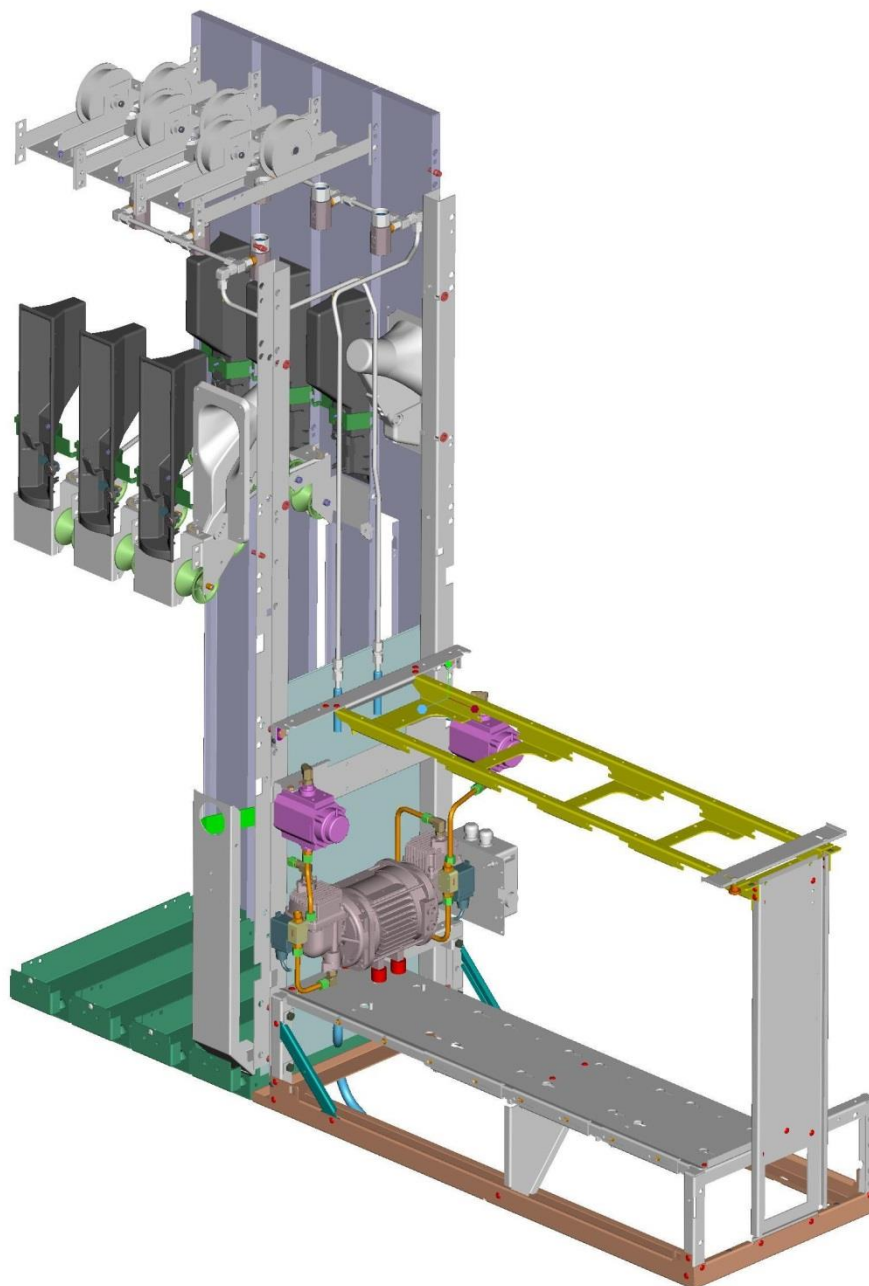

Typical Gilbarco Stage 2 (VR2) Vapour Recovery Collection and Monitoring Hydraulic System – Shown in frame for 6 petrol/diesel and 2 LPG hose and hydraulic modules

FIGURE 5/6M/3 – 13

Meter mapping – For 'W & M' (trade measurement) identification

For meter selection during delivery review (see TEST PROCEDURE)

For meter A select 1, for meter E select 5

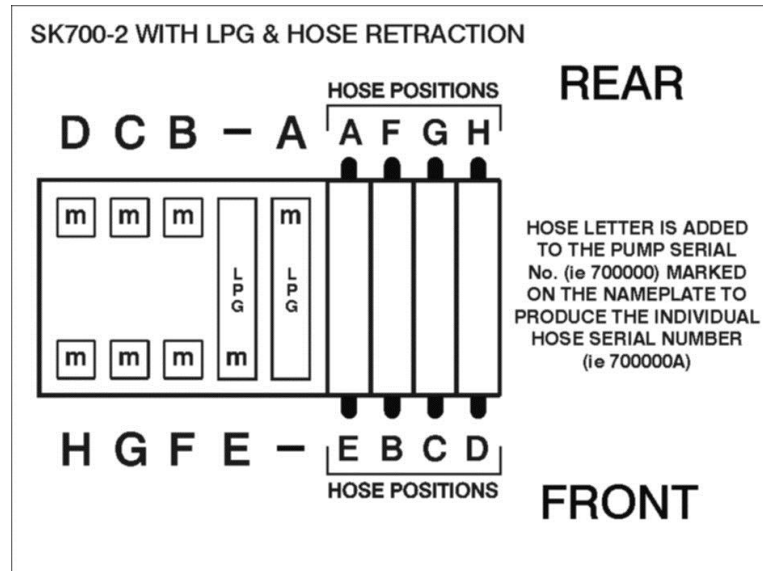

(a) Meter and hose relationship with hose retraction

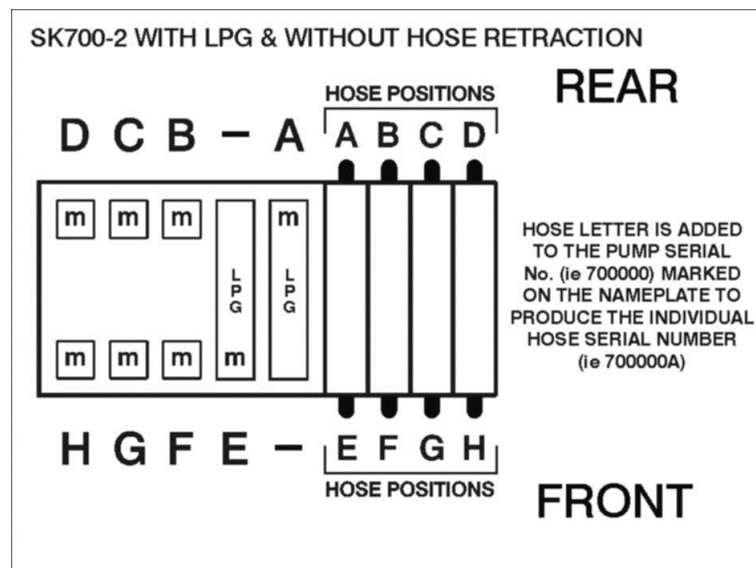

(b) Meter and hose relationship without hose retraction

Meter Mapping

~ End of Document ~