



Australian Government

Department of Industry,  
Science and Resources

**National  
Measurement  
Institute**

36 Bradfield Road, West Lindfield NSW 2070

**Certificate of Approval**

**NMI 5/6A/232**

Issued by the Chief Metrologist under Regulation 60  
of the  
National Measurement Regulations 1999

This is to certify that an approval for use for trade has been granted in respect of the instruments herein described.

Wayne Model Helix 6000 C (H/LM) 33-33S Fuel Dispenser for Motor Vehicles

Submitted by           Dover Fueling Solutions UK Ltd Filial  
                                  Hanogatan 8  
                                  211 24   Malmö  
                                  Sweden

**NOTE:** This Certificate relates to the suitability of the pattern of the instrument for use for trade only in respect of its metrological characteristics. This Certificate does not constitute or imply any guarantee of compliance by the manufacturer or any other person with any requirements regarding safety.

This approval has been granted with reference to document NMI R 117, Measuring Systems for Liquids Other than Water, dated June 2011.

This approval is subject to review at the decision of the Chief Metrologist in accordance with the conditions specified in the document NMI P 106.

**DOCUMENT HISTORY**

<b>Rev</b>	<b>Reason/Details</b>	<b>Date</b>
0	Pattern & variants 1 to 6 approved – interim certificate issued	30/07/14
1	Pattern & variants 1 to 6 amended (validity date) – interim certificate issued	28/11/14
2	Pattern & variants 1 to 6 amended (additional dispenser series) – interim certificate issued	13/03/15
3	Pattern & variants 1 to 7 approved – certificate issued	15/05/15

Document History (cont...)

Rev	Reason/Details	Date
4	Pattern & variant 8 approved – certificate issued	22/03/17
5	Pattern & Variant 5 amended (Manufacturer name) – Variant 1 amended (Helix 1000 model) – Variant 3 amended (Corrected description) – Variant 9 & 10 approved – certificate issued	19/12/17
6	Pattern amended (Submitted By & Variant Numbering) – Variant 11 approved – certificate issued	13/03/19
7	Variant 12 approved – Test procedure amended (hose numbering) – certificate issued	17/07/20
8	Pattern Amended (manufacturing site) – Variant 5 amended (additional VR2 approval) – Variant 13 to 15 approved – certificate issued	30/09/22

CONDITIONS OF APPROVAL

**General**

Instruments purporting to comply with this approval shall be marked with approval number 'NMI 5/6A/232' and only by persons authorised by the submittor.

It is the submittor's responsibility to ensure that all instruments marked with this approval number are constructed as described in the documentation lodged with the National Measurement Institute (NMI) and with the relevant Certificate of Approval and Technical Schedule. Failure to comply with this Condition may attract penalties under Section 19B of the National Measurement Act and may result in cancellation or withdrawal of the approval, in accordance with document NMI P 106.

Auxiliary devices used with this instrument shall comply with the requirements of General Supplementary Certificate No S1/0B.

Signed by a person authorised by the Chief Metrologist to exercise their powers under Regulation 60 of the *National Measurement Regulations 1999*.



**Alex Winchester**  
A/g Manager  
Policy and Regulatory Services

TECHNICAL SCHEDULE No 5/6A/232

**1. Description of Pattern**

**approved on 30/07/14  
amended on 30/09/22**

The Wayne model Helix 6000 C (H/LM) 33-33S fuel dispenser for motor vehicles (Figure 1 and Table 1) is approved to dispense various petrol or distillate (\*), in attendant-operated mode, or in unattended self-service mode using any compatible (#) approved control console. The meter is adjusted to be correct for the liquid for which it is to be verified.

- (\*) including up to 85% ethanol (E85) and various grades of pure biodiesel and biodiesel/distillate blends (to Australian government standard).
- (#) 'Compatible' is defined to mean that no additions/changes to hardware/software are required for satisfactory operation of the complete system.

The manufacturing site of the Wayne Helix series fuel dispensers is:

DOVER FUELING SOLUTIONS UK LTD  
Unit 3 Baker Road  
Dundee, DD5 3RT, Scotland

**1.1 Field of Operation**

The field of operation of the measuring system is determined by the following characteristics:

Minimum measured quantity, $V_{min}$	2 L	
Maximum flow rate, $Q_{max}$	40 L/min	
Minimum flow rate, $Q_{min}$	4 L/min	
Maximum pressure of the liquid, $P_{max}$	300 kPa	
Minimum pressure of the liquid, $P_{min}$	120 kPa	(#1)
Range of liquids viscosity (at 20°C)	0.5 to 20 mPa.s (at 20°C)	(#2)
Maximum temperature of the liquid, $T_{max}$	50°C	
Minimum temperature of the liquid, $T_{min}$	-10°C	
Ambient temperature range	-25 to 55°C	
Accuracy class	0.5	

- (#1) Minimum pressure required for effective operation of the gas elimination device.
- (#2) The flowmeter is adjusted for use with one product viscosity. Fuels include kerosene, distillate and various grades of petrol (which may include up to 10% ethanol).

**1.2 Description of the Metering System**

The metering system incorporates the following components:

- (i) Three Wayne model CPU compact pumping units each with an integral gas elimination device. The CPUs supporting 2 hoses/nozzles each.
- (ii) Three Wayne model WM002393-0001 (aka model iMeter) positive displacement four piston double-sided measurement transducers (Figure 2) each fitted with a Wayne model WM001682-0001 WIP ('Wayne Integrated Pulser') pulse generator (Figure 3) which produces 200 pulses per revolution.
- (iii) Six hoses/nozzles are used, three mounted on each side of the dispenser housing. This model is fitted with 16 mm hoses, ZVA Slimline 2 (21 mm)

nozzles, and 0.75 kW pump motors. Note that the submitter should be consulted regarding the acceptability of any alternative nozzles.

- (iv) An optional pre-set facility may also be fitted.

### 1.3 Calculator/Indicator

The Wayne model iGEM calculator/indicators (Figure 1), one per side, have a display for total price and for volume delivered, as well as a separate unit price display allocated for each nozzle.

The display limits and increments are:

Price (7 digits) up to 99999.00 in 0.01 cents

Volume (6 digits) up to 9999.00 in 0.01 L

Unit price (4 digits) up to 9999 in price/L

A decimal point for unit price may be shown and its position adjusted based on the value of the unit price (e.g. \$1.999/L or 199.9 c/L).

A pre-set facility (keypad and display) may also be fitted.

The instrument is approved with version 12.xx (#) software, which can be viewed by pressing '3' on the remote control or by pressing 'CRC' button on the iGEM computer board. The software version will appear on the unit price display.

- (#) The last two digits of the software version number (12.xx) may be any number greater than '02' (e.g. 12.03) – these last two digits represent features which are not metrologically significant.

### 1.4 Descriptive Markings and Notices

Instruments are marked with the following data, together in one location on a data plate:

Pattern approval sign	NMI 5/6A/232	
Manufacturer's identification mark or trade mark	.....	
Manufacturer's designation (model number)	.....	
Serial number	.....	
Year of manufacture	.....	
Maximum flow rate ( $Q_{max}$ )	..... L/min	
Minimum flow rate ( $Q_{min}$ )	..... L/min	
Minimum measured quantity ( $V_{min}$ )	..... L	(#1)
Maximum operating pressure ( $P_{max}$ )	..... kPa	
Minimum operating pressure ( $P_{min}$ )	..... kPa	
Nature of liquids to be measured	.....	(#2)
Maximum temperature of the liquid, $T_{max}$	.....°C	(#3)
Minimum temperature of the liquid, $T_{min}$	.....°C	(#3)
Environmental class	class C	

- (#1) In addition, the minimum measured quantity ( $V_{min}$ ) shall be clearly visible on any indicating device visible to the user during measurement, in the form 'Minimum delivery 2/5 L'.
- (#2) e.g. distillate or D, Diesel Exhaust Fluid (DEF) or AdBlue.
- (#3) Refer to clause **8.1 Field of Operation** for values for variant 7 (DEF).

## 1.5 Sealing Provision

The gas separator test valve has provision for sealing. The meter is sealed as shown in Figure 4. The model iGEM calculator/indicator has provision for sealing (Figure 5).

## 1.6 Verification Provision

Provision is made for the application of a verification mark.

## 1.7 Checking Facilities

An automatic segment test is performed at the start of each delivery.

The calculator monitors the presence and correct transmission of signal from the measurement transducer, and in the event of detecting a fault the instrument indicates an error code and has provision for controlling electrically-operated valves to stop the delivery.

## 2. Description of Variant 1

approved on 30/07/14

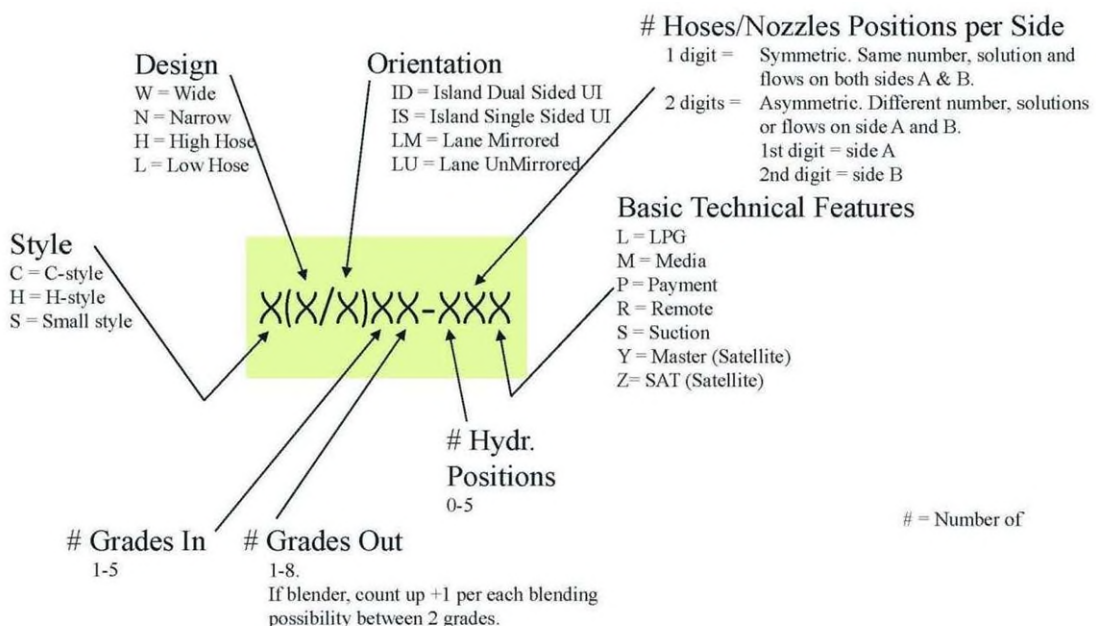
Certain other models and configurations of the Wayne Helix series of fuel dispensers identified using Table 1 below, including dispensers with from one (1) to ten (10) meters/hoses/nozzles (Figures 6 and 7).

TABLE 1 – Meaning of model designations for the Helix series of fuel dispensers: (the pattern is a model Helix 6000 C (H/LM) 33-33S)

1<sup>st</sup> four digits – Helix series, either;

1000 (1 or 2 hoses), 2000 (1 or 2 hoses), 4000 (1 to 4 hoses), 5000 (1 to 8 hoses) or  
6000 (1 to 10 hoses)

Other alphanumeric characters – model characteristics as set out below:



The shape and orientation of each model and configuration of the Wayne Helix fuel dispenser series can be seen in Figure 6. Figure 7 shows typical 2000 and 5000 series dispensers.

**3. Description of Variant 2** **approved on 30/07/14**

Instruments may be fitted with 21 mm hoses, ZVA Slimline 2 (25 mm) nozzles (\*), and 1.1 kW pump motors, in which case the fuel dispenser has the following field of operation:

- Maximum flow rate ( $Q_{max}$ ) 70 L/min
- Minimum flow rate ( $Q_{min}$ ) 7 L/min
- Minimum measured quantity ( $V_{min}$ ) 5 L

**4. Description of Variant 3** **approved on 30/07/14**

With two Wayne model CPU compact pumping units as described for the pattern supplying one double sided Dresser Wayne model WM002393-0001 flowmeter (aka iMeter) each. The A-side outlets from each meter are then connected to a ZVA (25 or 31 mm) nozzle (\*) using 32 mm piping, a 32 mm hose, and 1.1 kW pump motors for each pump.

Alternatively for single user dispenser two Wayne model CPU compact pumping units as described for the pattern supplying one double sided Dresser Wayne model WM002393-0001 flowmeter (aka iMeter). The outlet from A- and B-side on that meter are connected to a ZVA (25 or 31 mm) nozzle (\*) using 32 mm piping, a 32 mm hose, and 1.1 kW pump motors for each pump.

The field of operation of the measuring system is the same as listed for the pattern in clause **1.1 Field of Operation** except for the following:

- For use with distillate
- Maximum flow rate ( $Q_{max}$ ) 120 L/min
- Minimum flow rate ( $Q_{min}$ ) 12 L/min
- Minimum measured quantity ( $V_{min}$ ) 5 L

(\*) The submitter should be consulted regarding the acceptability of alternatives.

**5. Description of Variant 4** **approved on 30/07/14**

With one or more compatible submersible turbine pumps (STPs) incorporating a leak detection system (Figure 8). The STP replaces the equivalent components (i.e. motor, pump/strainer/gas separator, and associated pipework) in certain fuel dispensers covered by this approval (refer to Table 1). Figure 9 shows an iMeter with inlet for submersible turbine pump system, including typical sealing.

More than one fuel dispenser may be connected to the same submersible turbine pump.

Dispensers may operate with the standard maximum flow rate,  $Q_{max}$  of 40 L/min, or with the increased maximum flow rate,  $Q_{max}$  of 70 L/min (Variant 2), or dispensers for use with distillate may be used with the high maximum flow rate,  $Q_{max}$  of 120 L/min (Variant 3)

**6. Description of Variant 5** **approved on 30/07/14**  
**amended on 30/09/22**

Any fuel dispenser of this approval now fitted with a Wayne model Vapour Recovery II vapour recovery system and used up to a maximum flow rate of 40 L/min. Typical systems are shown in Figures 10 and 11.

The vapour recovery and monitoring system is approved by the German TÜV SÜD Industrie Service GmbH authority.

Only vapour recovery components and systems as listed below and included in the above TÜV approval certificates may be used.

The relevant TÜV approvals (and the approved components) are:

(i) For collection of vapour:

- TÜV certificate 85-2.23-2
- EN16321-1 certificate no. VR2 – 1503 – 157 EU,

and the only approved system components are:

- Vapour recovery nozzle – Elaflex models ZVA 200 GR or ZVA Slimline 2
- Coaxial hose – Elaflex model Conti Slimline 2 1/8 Coax
- Control valve – Burkert model 6022
- Control valve – ASCO EMXX valve
- Control board – Burkert model 2832
- Controller board – Dover VR
- Vapour recovery pump(s) – Durr models MEX 0544, MEX 0831-10, or MEX 0831-11.

(ii) For automatic monitoring of the vapour to fuel ratio:

- TÜV certificate Ü-12.14
- EN16321-1 certificate no. VR2 – 1503 – 167 EU,

and the only approved system components are:

- Monitor –Wayne model VapourGate monitoring system
- Monitor –DFS model VFM monitoring system  
Flowmeter –Wayne model VR flowmeter
- Flowmeter – DFS VFM VR flowmeter
- Controller board – Dover VR
- Controller –Wayne model iGEM dispenser processor

## **7. Description of Variant 6**

**approved on 30/07/14**

For use with a Xflo™ flowmeter (Figures 12 and 13) replacing the Wayne AB model WM002393-0001 (aka model iMeter) positive displacement four piston double-sided measurement transducers.

## **8. Description of Variant 7**

**approved on 15/05/15**

With one or more nozzles for dispensing Diesel Exhaust Fluid (DEF) in attendant-operated mode, or in attended self-service mode using any compatible (#) approved control console. The meter is adjusted to be correct for the liquid for which is verified.

## 8.1 Field of Operation

The field of operation of the measuring system is the same as listed for the pattern in clause 1.1 **Field of Operation** except for the following:

- Dynamic viscosity 1.4 mPa.s (at 25°C) (##)
- Maximum temperature of the liquid,  $T_{max}$  30°C
- Minimum temperature of the liquid,  $T_{min}$  0°C

(##) The dispenser is adjusted to be correct for Diesel Exhaust Fluid (AUS32 - aqueous urea solution 32.5%) for which it is to be verified.

## 9. Description of Variant 8 approved on 22/03/17

With one or more Wayne model iMeter2 positive displacement four piston double-sided or single-sided measurement transducers (Figure 14).

## 10. Description of Variant 9 approved on 19/12/17

With the calculator/indicator of any fuel dispenser model of this approval now fitted with a Wayne model iGEM 2 calculator/indicator.

The instrument is approved with version 013.XXX.XXX (#) software, which can be viewed by pressing '3' on the remote control or by pressing 'CRC' button on the iGEM computer board. (Figure 15) The software version will appear on the sales volume display. An example is showed in Figure 16.

(#) The last six digits of the software version number (013.XXX.XXX) may be any number greater than '004.000' (e.g. 013.004.012) – these last six digits represent features which are not metrological significant.

### 10.1 Sealing Provision

The model iGEM 2 calculator/indicator has provision for sealing (Figure 17)

### 10.2 Optional additive liquid injection system

The iGEM 2 calculator/indicator includes an optional additive liquid injection system. The system comprises an additive tank and pump, an additive meter or tank gauge and solenoid valves to control the additive to be injected into the liquid. The additive is injected before the metering system of the fuel dispenser (Figure 18)

The iGEM 2 includes checking facilities to ensure that sufficient additive liquid is available in the tank and air cannot be introduced into the liquid. When the system detects insufficient additive the delivery will be stopped. Further deliveries with additive injection are prevented until the additive tank is filled.



**11. Description of Variant 10**

**approved on 19/12/17**

With two Wayne model CPU compact pumping units as described for the pattern supplying one double sided Dresser Wayne model WM002393-0001 flowmeter (aka iMeter) each. The A- and B-side outlets from each meter are then connected to one ZVA (31 mm) nozzle (\*) using 32 mm piping, a 32 mm hose, and 1.1 kW pump motors for each pump.

The field of operation of the measuring system is the same as listed for the pattern in clause **1.1 Field of Operation** except for the following:

- For use with distillate
- Maximum flow rate ( $Q_{max}$ ) 180 L/min
- Minimum flow rate ( $Q_{min}$ ) 18 L/min
- Minimum measured quantity ( $V_{min}$ ) 5 L

(\*) The submitter should be consulted regarding the acceptability of alternatives

**12. Description of Variant 11**

**approved on 13/03/19**

With the Wayne model iGEM 2 calculator/indicator of variant 9 approved with version 014.XXX.XXX (#) software. The iGEM 2 calculator/indicator may also be interfaced to an iGEM 2 I/O Gen 2 board which replaces the first generation I/O board of the pattern. The I/O Gen 2 board provides additional input, output and communication interfaces.

(#) The last six digits of the software version number (014.XXX.XXX) may be any number greater than '005.000' (e.g. 014.005.012) – these last six digits represent features which are not metrological significant

**13. Description of Variant 12**

**approved on 17/07/20**

Revision 4 of the hardware circuit boards of the iGEM 2 calculator/indicator comprises layout changes of components of the circuit boards of variant 9.

With variants comprising the iGEM 2 calculator/indicator approved with software version 015.XXX.XXX (#) software.

This variant does change any of the metrological properties or field of operation.

(#) The last six digits of the software version number (015.XXX.XXX) may be any number greater than '008.000' (e.g. 015.008.007) – these last six digits represent features which are not metrological significant

**14. Description of Variant 13** **approved on 30/09/22**

With Wayne Helix series described in Variant 1 utilising the Wayne model CPU compact pumping units now having the motor repositioned between the pumping unit and the meter shown in Figure 20.

Fuel dispensers of this variant are identified by appending “-II” to the model number, e.g. Helix 6000-II, Helix 5000-II, Helix 4000-II using the updated model nomenclature shown below:

**New naming convention for Helix 6000 II dispensers.**

First number denoting number of available grades, second the total number of nozzles and third the number of hose columns.  
Non-Standard models has additional denomination.

**Model Nomenclature:**



**15. Description of Variant 14** **approved on 30/09/22**

A Wayne model Century 3 series fuel dispenser which is configured the same components as the Wayne Helix 1000 and Helix 2000 fuel dispensers with a different size housing shown in Figure 21.

**16. Description of Variant 15** **approved on 30/09/22**

With variants comprising the iGEM 2 calculator/indicator approved with software version 017.XXX.XXX (#) and software 018.XXX.XXX (#) software.

This variant does change any of the metrological properties or field of operation.

(#) The last six digits of the software version number may be any number – these last six digits represent features which are not metrological significant

## TEST PROCEDURE No 5/6A/232

Instruments shall be tested in accordance with any relevant tests specified in the National Instrument Test Procedures.

The instrument shall not be adjusted to anything other than as close as practical to zero error, even when these values are within the maximum permissible errors.

### **Maximum Permissible Errors**

The maximum permissible errors are specified in Schedule 1 of the *National Trade Measurement Regulations 2009*.

### **Tests**

Tests should be conducted in conjunction with any tests specified in the approval documentation for any components used, including indicator/controller and submersible turbine pump (STP) hydraulic systems.

### **Hose Configuration**

Where the serial number on the data plate is 939884, the side identification (A or B) and hose number are added to the instrument serial number for individual hose serial numbers e.g. 939884A1, 939884B2.

Refer Figure 6 for Shape and Orientation of Wayne Helix Fuel Dispensers and hose numbering.

Refer Figure 19 for detail of the side identification marking location.

FIGURE 5/6A/232 – 1



Wayne Model Helix 6000 C (H/LM) 33-33S Fuel Dispenser for Motor Vehicles (Pattern)

FIGURE 5/6A/232 – 2



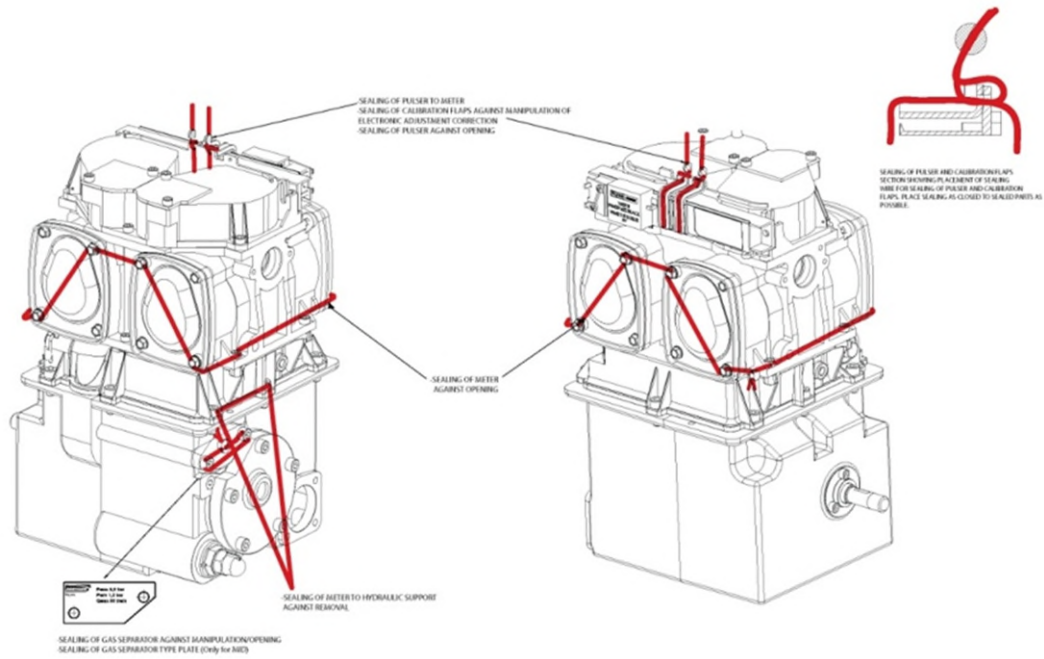
Wayne Model WM 002393-001 (aka model iMeter)  
Measurement Transducer

FIGURE 5/6A/232 – 3



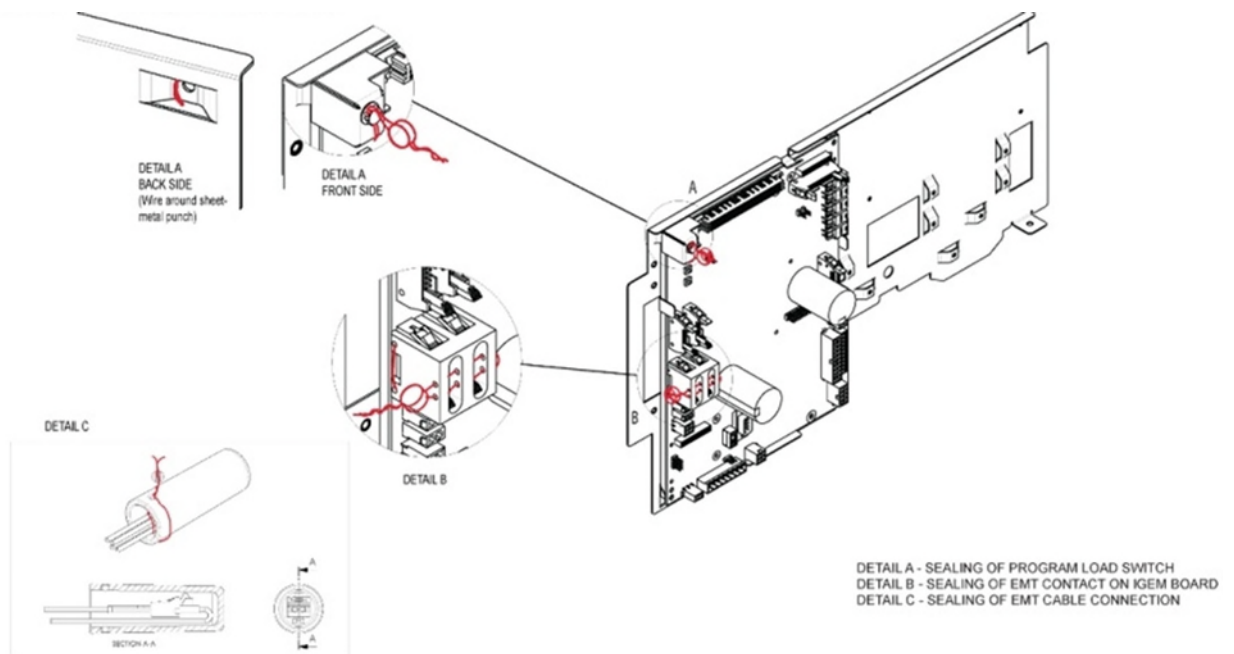
Wayne Model WM 001682 WIP Pulse Generator

FIGURE 5/6A/232 – 4



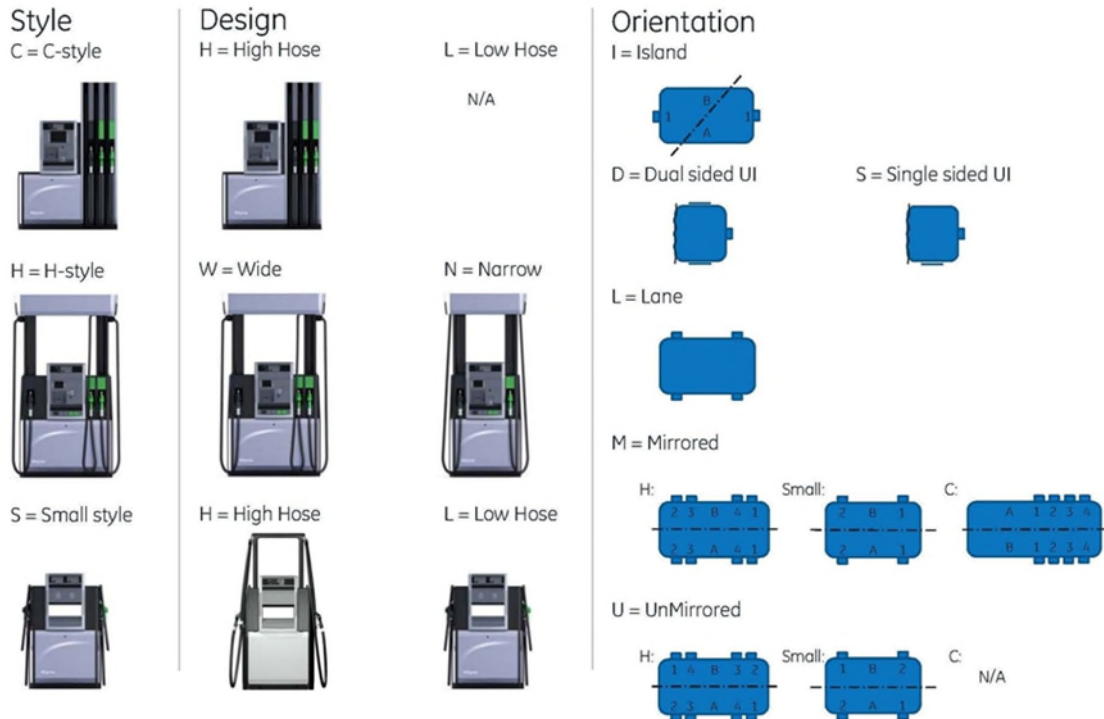
Sealing of iMeter and Pump Unit (Pattern)

FIGURE 5/6A/232 – 5



Sealing of iGEM Calculator/Indicator Unit (Pattern & Variants)

FIGURE 5/6A/232 – 6



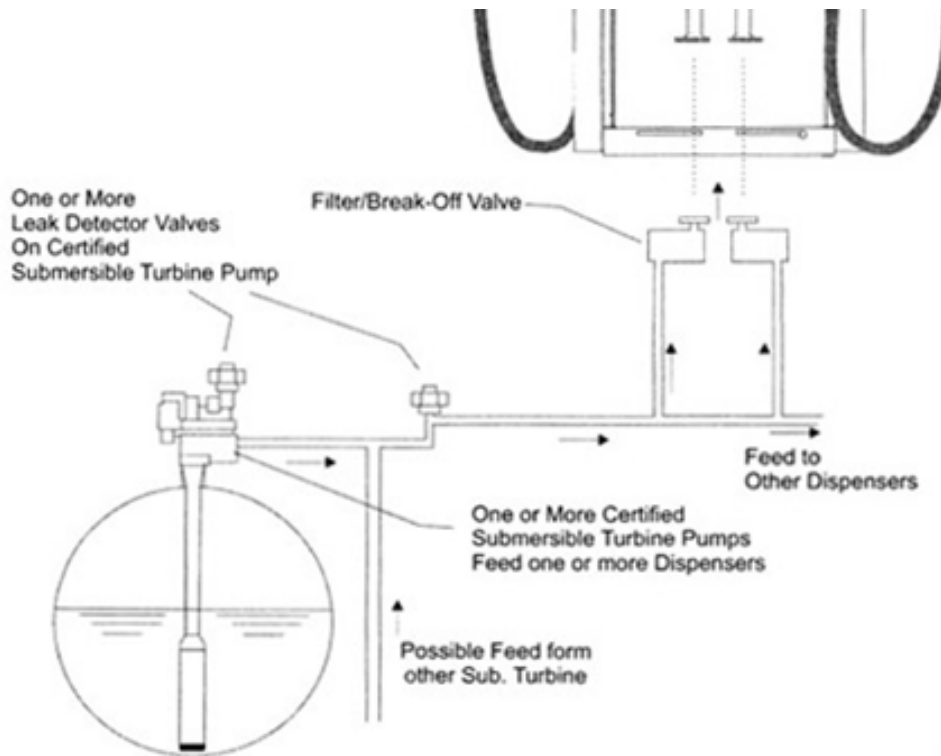
Shape and Orientation of Wayne Helix Fuel Dispensers Variant 1 (refer Table 1)

FIGURE 5/6A/232 – 7



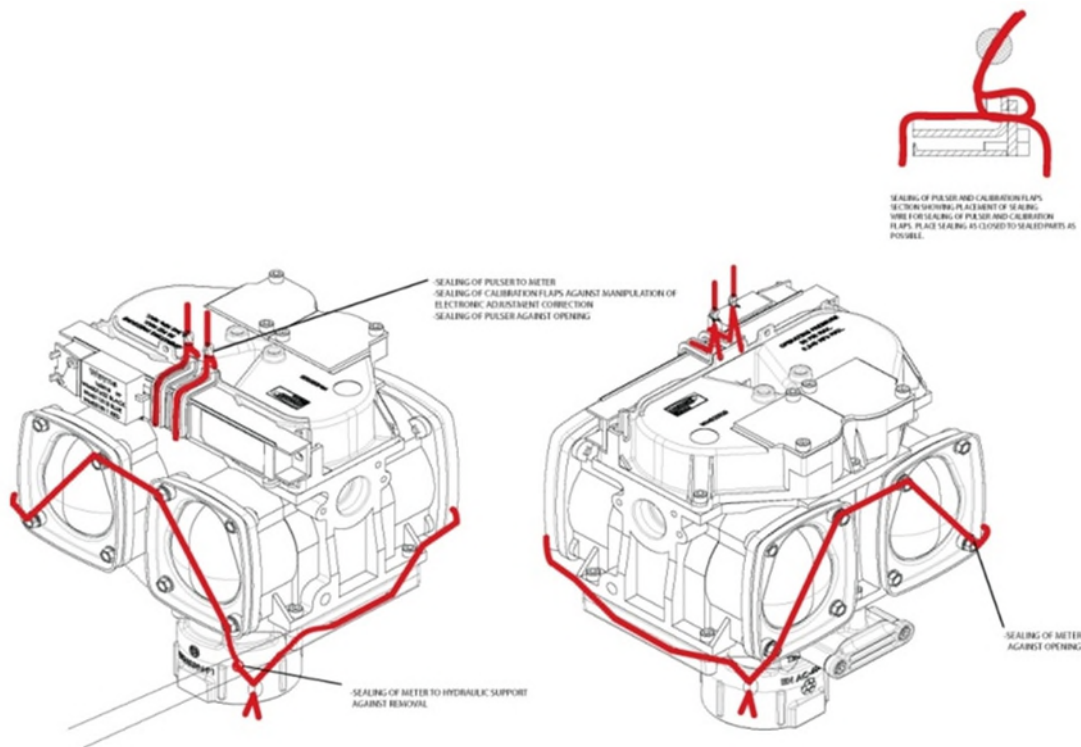
Typical Wayne Helix 2000 & Helix 5000 Series Fuel Dispensers (Variant 1)

FIGURE 5/6A/232 – 8



Typical Submersible Turbine Pump (STP) System (Variant 4)

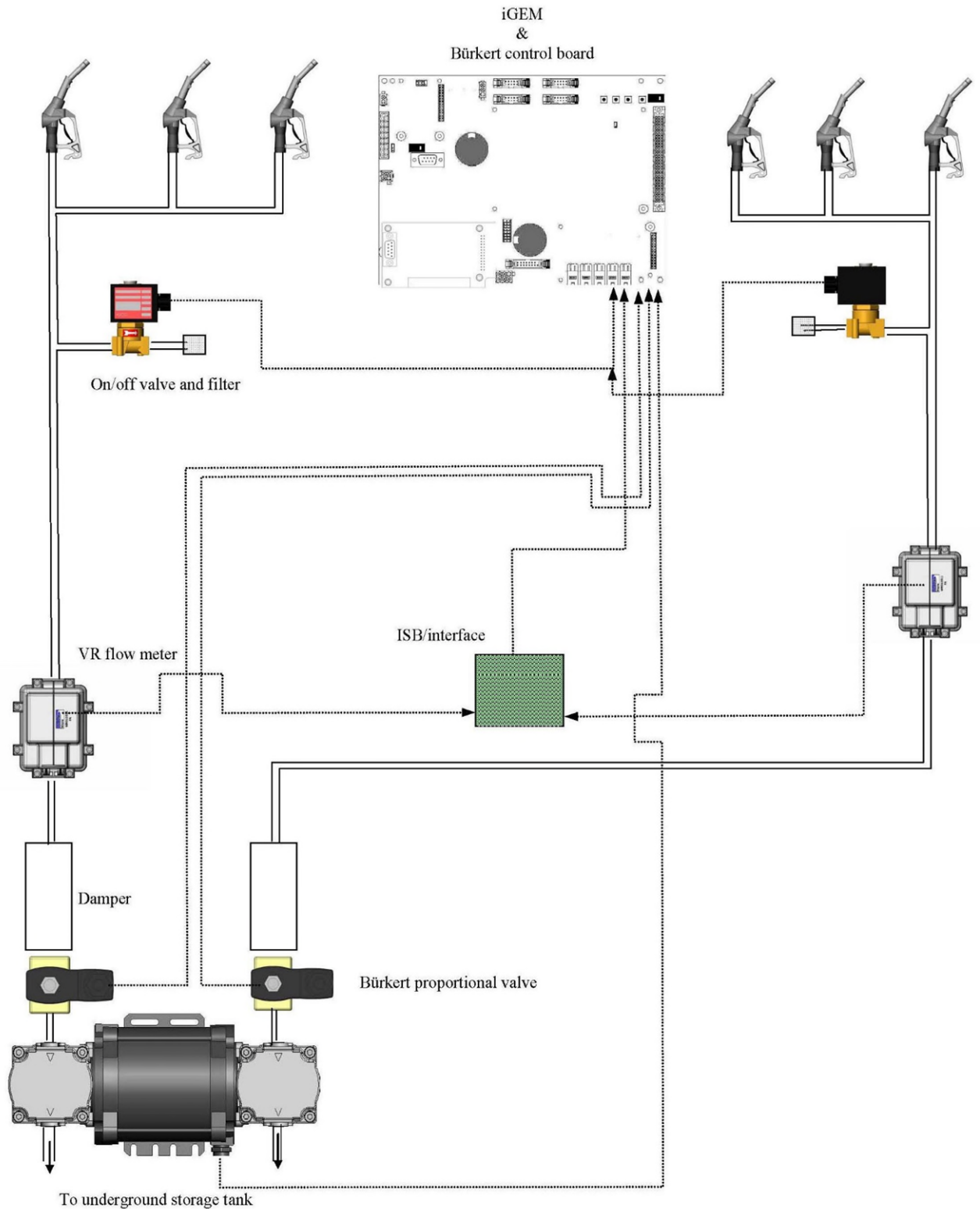
FIGURE 5/6A/232 – 9



Showing Typical Sealing Method for an STP System (Variant 4)

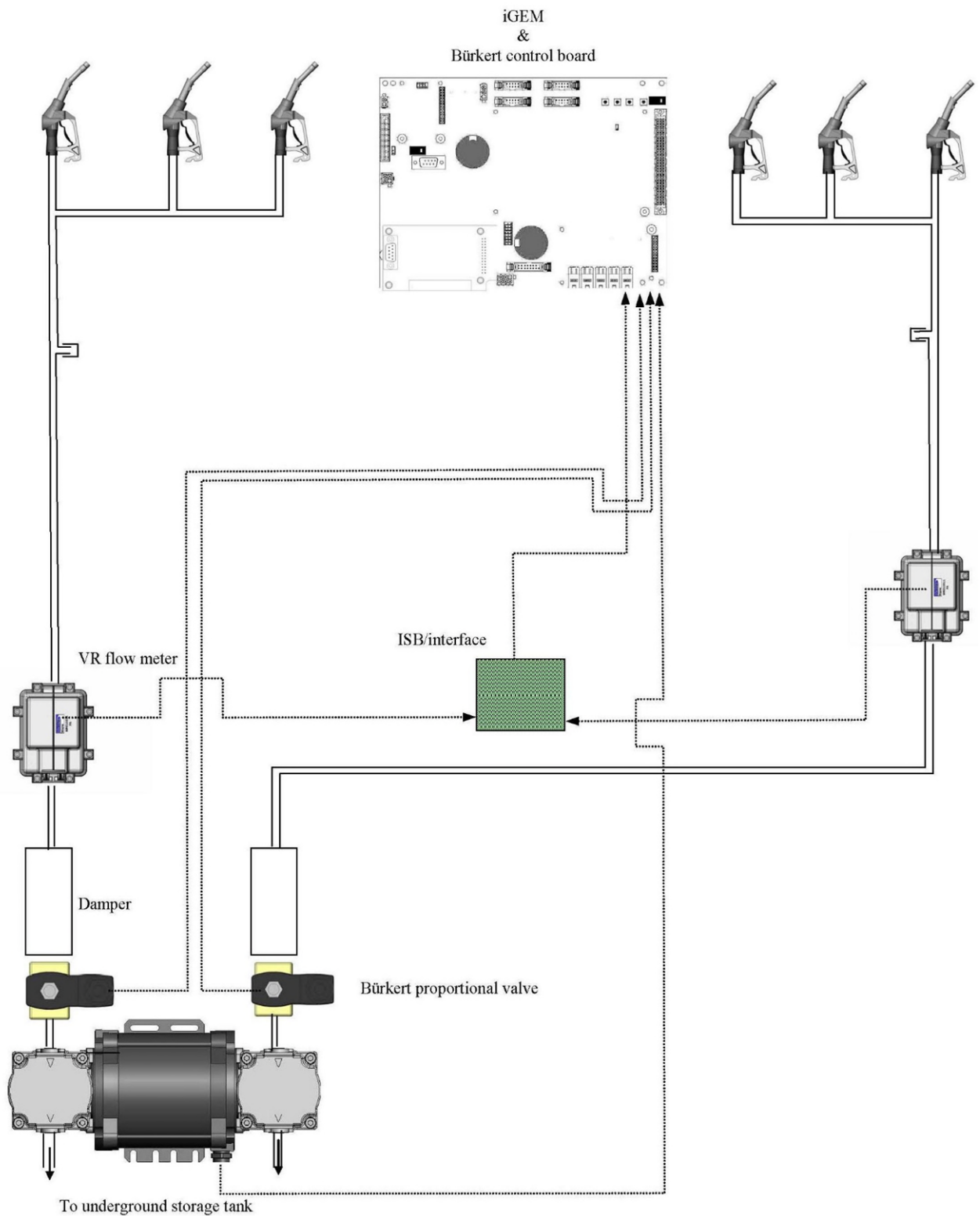


FIGURE 5/6A/232 – 10



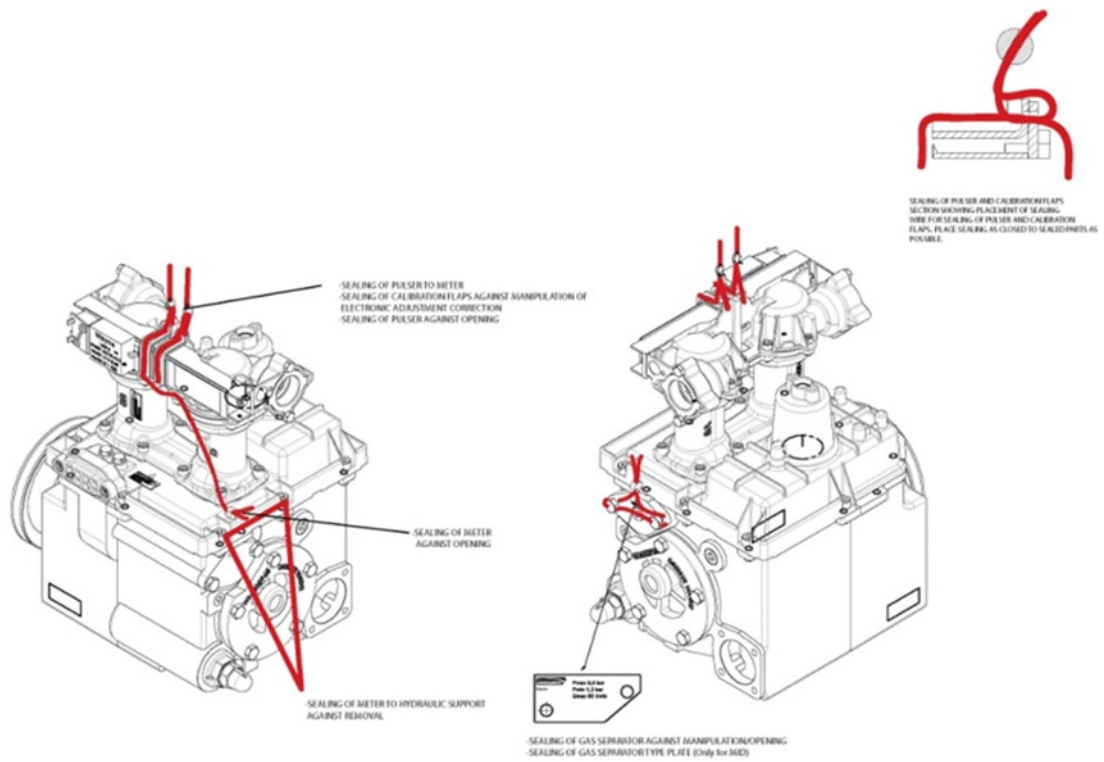
Wayne Model Vapour Recovery II Vapour Recovery System  
(with self-check facility) (Variant 5)

FIGURE 5/6A/232 – 11



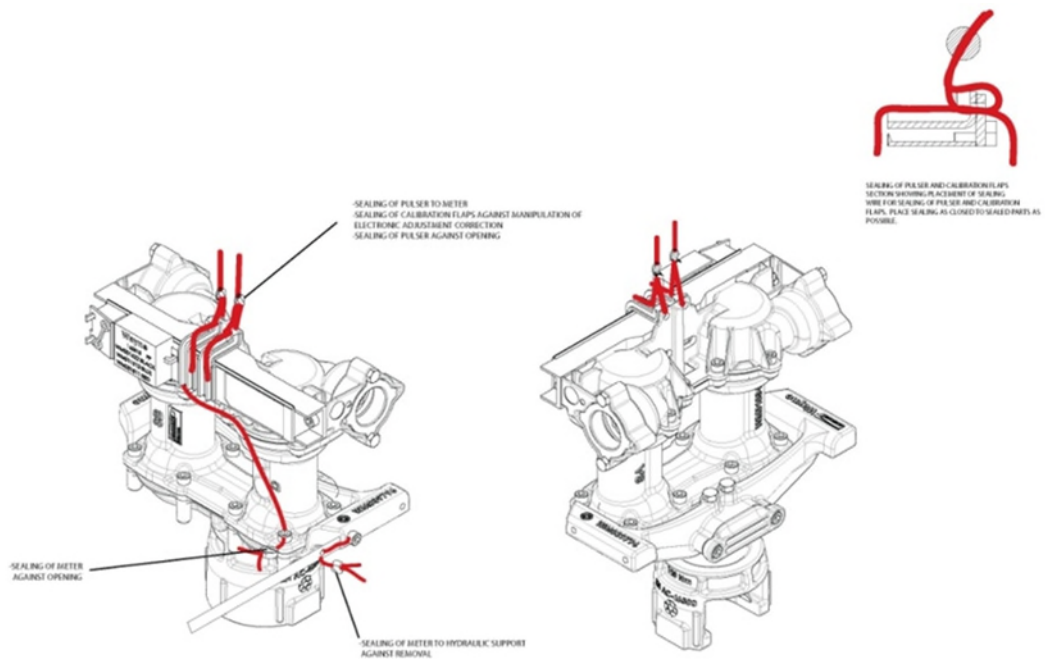
Wayne Model Vapour Recovery II Vapour Recovery System  
(without self-check facility) (Variant 5)

FIGURE 5/6A/232 – 12



Model XFlo Flowmeter including Sealing of Meter and Pumping Unit (Variant 6)

FIGURE 5/6A/232 – 13

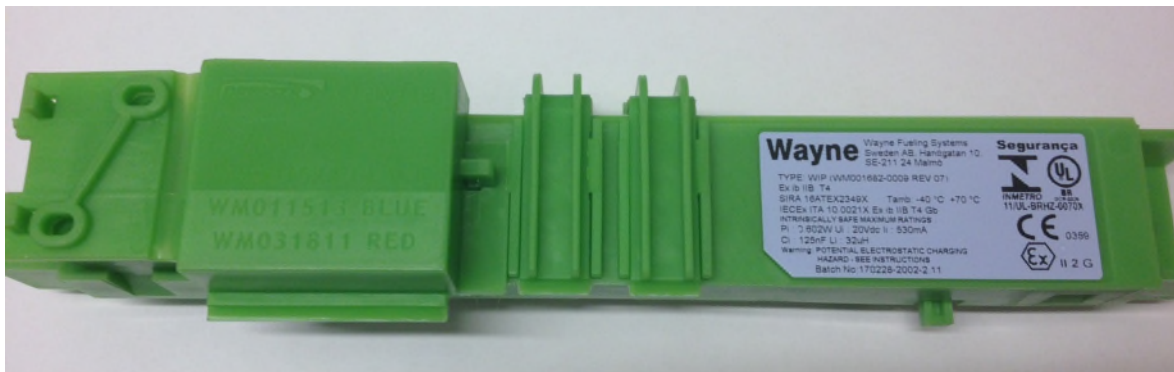


Model XFlo Flowmeter including Sealing of Meter and STP Unit (Variants 4 & 6)

FIGURE 5/6A/232 – 14

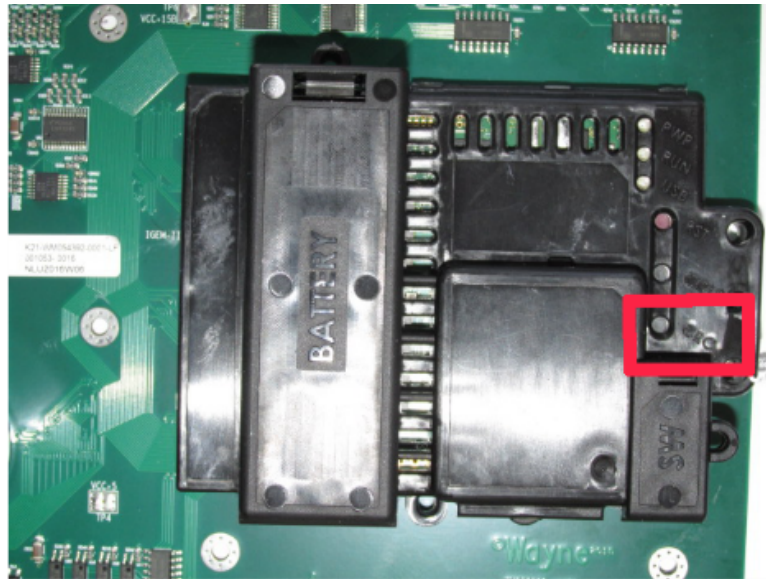


Wayne model Imeter<sup>2</sup> positive displacement four piston double-sided measurement transducers



Wayne Model WM 001682 WIP Pulse Generator

5/6A/232 - 15



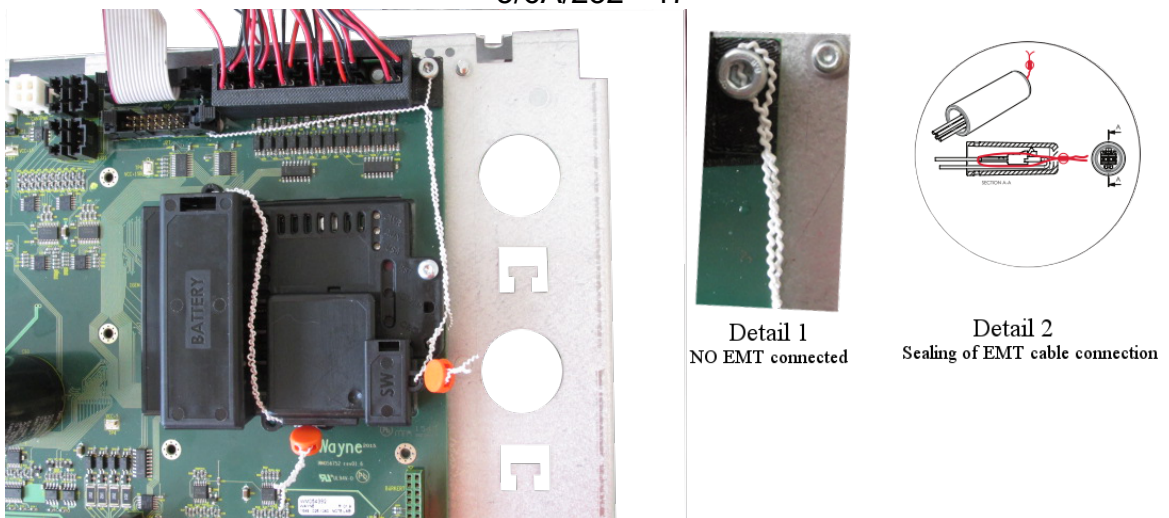
CRC button placement on Wayne iGEM 2 Calculator.

5/6A/232 - 16



Example of dispenser application version on Wayne iGEM 2 Calculator.

5/6A/232 - 17

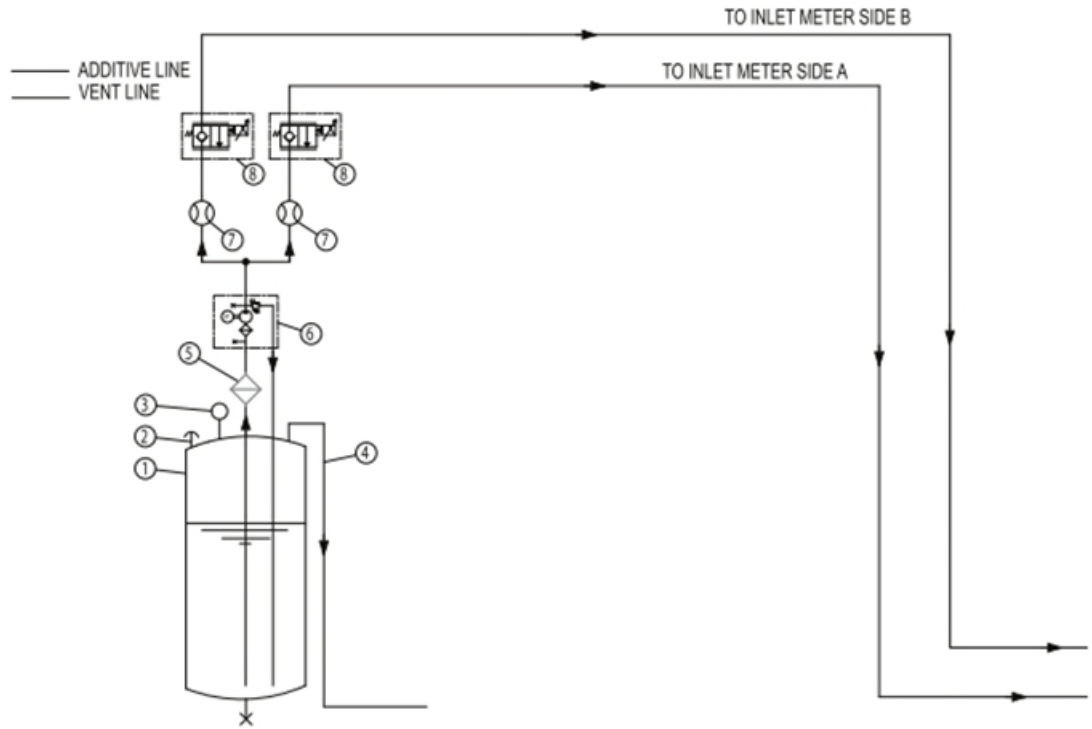


Sealing of Wayne iGEM 2 Calculator.

5/6A/232 - 18

ITEM	DESCRIPTION
1	Tank
2	Filler Cap
3	Level Switch
4	Vent
5	Inlet Filter
6	Pump Unit
7	Flow Meter
8	Solenoid Valve

BASIC ADDITIVE HYDRAULIC CIRCUIT



Note: diagram is related to a double side dispenser

Wayne Additive system.

5/6A/232 – 19

A and B side is recognized by removing one of the doors from the hydraulic cabinet and look at the sheet metal support for pumping units (suction-dispensers) or meters (remote-dispensers). There is the letter A or B punched in to the sheet metal as can be seen in the pictures below.



remote pump



suction pump

Wayne Helix Fuel Dispensers side identification marking

5/6A/232 – 20



Repositioned motor between pumping unit and meter (Variant 13)

5/6A/232 – 21



Wayne Fuelling mode Century 3 Fuel Dispenser (Variant 14)

~ End of Document ~