



# NATIONAL STANDARDS COMMISSION

## WEIGHTS & MEASURES (PATTERNS OF INSTRUMENTS) REGULATIONS

### REGULATION 9

#### CERTIFICATE OF APPROVAL No 5/6D/29

This is to certify that an approval has been granted by the Commission that the pattern and variants of the

Acme (Lubricating Oil) Flowmeter With Neptune 38 mm Type 4 Meter

submitted by Acme Oil Equipment Services Pty Ltd  
253 Ingles Street  
Port Melbourne, Victoria, 3207

are suitable for use for trade.

The approval is subject to review on or after 1/7/81.

Instruments purporting to comply with this approval shall be marked with NSC No 5/6D/29.

Relevant drawings and specifications are lodged with the Commission.

#### Conditions of Approval

1. The flow rate is limited to between 10 L/min and 100 L/min.
2. The maximum system pressure is 500 kPa.
3. The pump suction operates under a positive liquid head.
4. The viscosity of the liquid to be measured lies in the range 100 mPa.s to 1000 mPa.S for a temperature range of 5°C to 40°C.
5. The type of liquid for which the instrument is verified is marked on the instrument data plate.

Signed

Executive Director

#### Descriptive Advice

Pattern: approved 25/6/76

- Acme (lubricating oil) flowmeter with Neptune 38 mm type 4 meter and Neptune type 442 indicator and set stop counter.

Variants: approved 25/6/76

1. With Neptune type 441 indicator.
2. With Neptune type 443 indicator and ticket printer.
3. With Neptune type 444 indicator, ticket printer and set stop counter.

Technical Schedule No 5/6D/29 dated 29/10/76 describes the pattern and variants 1 to 3.

28/12/82

...../2

Variant: approved 14/12/76

4. With any type, bore or length of hose.

Technical Schedule No 5/6D/29 Variation No 1 dated 27/1/77 describes variant 4.

Variant: approved 3/12/82

5. With an internal float valve which replaces the low level cut-off system fitted to the pattern.

Technical Schedule No 5/6D/29 Variation No 2 dated 28/12/82 describes variant 5.

Filing Advice

Certificate of Approval No 5/6D/29 dated 27/1/77 is superseded by this Certificate and may be destroyed. The documentation for this approval now comprises:

Certificate of Approval No 5/6D/29 dated 28/12/82  
Technical Schedule No 5/6D/29 dated 29/10/76 (including Special Tests)  
Technical Schedule No 5/6D/29 Variation No 1 dated 27/1/77 (including Table 1)  
Technical Schedule No 5/6D/29 Variation No 2 dated 28/12/82  
Test Procedure No 5/6D/29 Variation No 2 dated 28/12/82  
Figures 1 to 7 dated 29/10/76  
Figure 8 dated 28/12/82.



## NATIONAL STANDARDS COMMISSION

### TECHNICAL SCHEDULE No 5/6D/29

Pattern: Acme (Lubricating Oil) Flowmeter with Neptune 38-mm  
Type 4 Meter

Submittor: Acme Oil Equipment Services Pty Ltd,  
253 Ingles Street,  
Port Melbourne, Victoria, 3207.

Date of Approval: 25 June 1976

#### Conditions of Approval:

1. The flow rate is limited to between 10 and 100 litres per minute.
2. The maximum system pressure is 500 kPa.
3. The pump suction operates under a positive liquid head.
4. The viscosity of the liquid to be measured lies in the range 100 to 1000 mPa.s for a temperature range of 5°C to 40°C.
5. The liquid (commercial or technical name) for which the instrument is verified is nominated on the instrument data plate.

All instruments conforming to this approval shall be marked "NSC No 5/6D/29".

#### Description:

The pattern (see Figure 1) is a vehicle-mounted instrument for the delivery of liquid petroleum of viscosity between 100 and 1000 mPa.s at a flow rate between 10 and 100 litres per minute and at a maximum system pressure of 500 kPa.

The flowmeter comprises the following:

1. Mowbrey low-level float switch in the supply tank which ensures that the delivery stops before the liquid level falls low enough to allow air to enter the system (see Figure 1).
2. Positive displacement pump mounted on the assembly at a point lower than the minimum height of the liquid in the supply tank.

3. Non-return valve located between the pump and meter, or between the meter and the hose.
4. Neptune 38-mm Type 4 meter (see Figure 2).
5. Neptune Type 442 zero-start indicator and set-stop counter (see Figure 2). The indicator has a scale interval of 1 litre; the first element is marked with ten scale-mark lines numbered from 0 to 9. The aperture through which the first element is viewed is widened in the direction of travel.
6. Neptune outlet-control valve (see Figure 2).
7. Hydraulically operated shut-off valve with electrical solenoid control, which stops a delivery when the level of liquid in the supply tank is below the set minimum, the supply of electrical power fails, or the diaphragm in the valve ruptures (see Figure 3).
8. Hose — up to 20 metres of 32-mm bore Nylex hose.
9. Anti-drain valve (see Figure 4) — an anti-drain valve and swivel coupling is fitted on the end of the hose. The anti-drain valve retains a pressure of not less than 50 kPa.
10. Nozzle — any nozzle fitted with an integral anti-drain valve which retains a pressure of not less than 10 kPa and which is located downstream of the main nozzle valve.
11. Marking — instrument data plate(s) sealed to the instrument, marked:
  - (a) "approved for ....x.... lubricating oil",  
where x is the commercial or technical name; for example, "Shell Super" or "SAE 30",
  - (b) "maximum flow rate 100 litres per minute".
12. Sealing — the following parts of the flowmeter are sealed with a lead stamping plug:
  - (a) the meter and indicator (see Figure 2);
  - (b) the instrument data plate.

The approval includes:

1. The flowmeter with a zero-start Neptune Type 441 indicator with

a scale interval of 1 litre; the first element is marked with ten scale-mark lines numbered from 0 to 9. The aperture through which the first element is viewed is widened in the direction of travel (see Figure 5).

2. The flowmeter with a zero-start Neptune Type 443 indicator and ticket printer. The ticket printer has 1-litre increments and the indicator has a scale interval of 1 litre; the first element is marked with ten scale-mark lines numbered from 0 to 9. The aperture through which the first element is viewed is widened in the direction of travel (see Figure 6).
3. The flowmeter with a zero-start Neptune Type 444 indicator, ticket printer and set-stop counter. The ticket printer has 1-litre increments and the indicator has a scale interval of 1 litre; the first element is marked with ten scale-mark lines numbered from 0 to 9. The aperture through which the first element is viewed is widened in the direction of travel (see Figure 7).

#### Special Tests:

The instrument should be tested with the liquid for which it will be used, the name of which is marked on the instrument data plate.

#### Minimum Delivery:

1. The non-flow-dependent errors are up to:
  - (a) 1-litre rounding error for the ticket printer with 1-litre increments;
  - (b) 0,2-litre reading error for the indicator, which has the first element indicating by 1-litre scale intervals;
  - (c) 0,8-litre nose dilation.
2. When a ticket printer is fitted, the minimum delivery for which the relative errors from all sources would not exceed 1,5% is 150 litres.
3. Without a ticket printer the minimum delivery for which the relative errors from all sources would not exceed 1,5% is 100 litres.

#### Hose Dilation:

A measure of the nose-dilation quantity may be obtained by the

following method:

With the pump stopped and the hose unwound from the reel, open the nozzle to reduce the pressure in the hose to the anti-drain valve retaining pressure of about 50 kPa. Then zero the indicator, start the pump and, after allowing not less than 30 seconds for the hose to fully dilate, read the quantity on the indicator. This quantity is equal to the hose dilation.

#### Variation of Quantity in Nozzle:

If the integral anti-drain valve in the nozzle is not fitted or is not operating, the quantity of liquid contained in the nozzle and its fittings between the external anti-drain valve and the main nozzle valve will be an additional non-flow-dependent error for which no allowance has been made in the calculation of minimum delivery.

The efficiency of the integral anti-drain valve may be determined by the following method:

Start the pump, open and close the main nozzle valve, stop the pump, through the drain plug reduce the hose pressure to less than 55 kPa and then open the nozzle main valve. There should be no significant draining from the nozzle if the integral anti-drain valve is satisfactory.



# NATIONAL STANDARDS COMMISSION

TECHNICAL SCHEDULE No 5/6D/29

VARIATION No 1

Pattern: Acme (Lubricating Oil) Flowmeter with Neptune 38-mm  
Type 4 Meter

Submitter: Acme Oil Equipment Services Pty Ltd,  
253 Ingles Street,  
Port Melbourne, Victoria, 3207

Date of Approval of Variation: 14 December 1976

The modification described in this Schedule applies to the patterns described in Technical Schedule No 5/6D/29 dated 29 October 1976.

All instruments conforming to this approval shall be marked "NSC No 5/6D/29".

Description:

The approved modification provides for any type, bore or length of hose provided that the minimum delivery determined from Table 1 and marked on the instrument's data plate for reference by the Weights and Measures Authority is acceptable to that Authority taking into account the usage of the instrument.

Special Tests:

Hose Dilation:

A measure of the hose-dilation quantity may be obtained by the following method:

With the pump stopped and the hose fully wound on its reel, open the nozzle to reduce the pressure in the hose to the anti-drain valve retaining pressure of about 55 kPa. Then fully unwind the hose from the reel, zero the indicator, start the pump and, after allowing not less than 30 seconds for the hose to fully dilate, and with the pump still running, read the quantity on the indicator. This quantity is equal to the maximum hose dilation.

Technical Schedule No 5/6D/29 - Variation 1

TABLE 1

Minimum delivery (Indicator only - no ticket printer fitted)	Minimum delivery (ticket printer fitted)	Maximum permitted nose dilation
ℓ	ℓ	ml
25	100	50
50	125	300
75	150	500
100	175	800
125	200	1000
150	225	1300
175	250	1500
200	275	1800
225	300	2000
250	325	2300
275	350	2500
300	375	2800
325	400	3000
350	425	3300
375	450	3500
400	475	3800
425	500	4000
450	525	4300
475	550	4500
500	575	4800





# NATIONAL STANDARDS COMMISSION

TECHNICAL SCHEDULE No 5/6D/29

VARIATION No 2

Pattern: Acme (Lubricating Oil) Flowmeter With Neptune 38 mm Type 4 Meter

Submittor: Acme Oil Equipment Services Pty Ltd  
253 Ingles Street  
Port Melbourne, Victoria, 3207.

1. Description of Variant 5

With an internal float valve in the supply tank which replaces the Mowbray low level float switch and hydraulically operated shut-off valve fitted to the pattern (Figure 8).

28/12/82

TEST PROCEDURE No 5/6D/29

VARIATION No 2

Note: The instrument should be tested with the liquid with which it will be used; the viscosity range or type of liquid is marked on the data plate.

The maximum permissible errors at verification are:

- (a)  $\pm 0.3\%$  for all flow rates, when the operating flow rate varies by more than 10 L/min within the approved maximum and minimum flow rates marked on the data plate, the system having been calibrated at the maximum approved flow rate.
  - (b)  $\pm 0.15\%$ , when the operating flow rate is within  $\pm 5\%$  of the nominal flow rate being marked on the data plate.
1. Make at least one delivery at maximum flow rate during which the liquid in the supply tank falls to the level at which the float valve operates and stops the delivery into the proving measure. Replenish the supply tank with at least sufficient liquid to allow the delivery to be completed before the liquid level in the supply tank again causes the float valve to operate. The effect on the measured quantity should not create an error which exceeds 1% of the minimum delivery.
  2. Test delivery - if the test delivery is less than ten times the minimum delivery, the reading error of the indicator or the rounding error of the ticket printer is minimised by completing the delivery at a graduation line.

FIGURE 5/6D/29 - 1

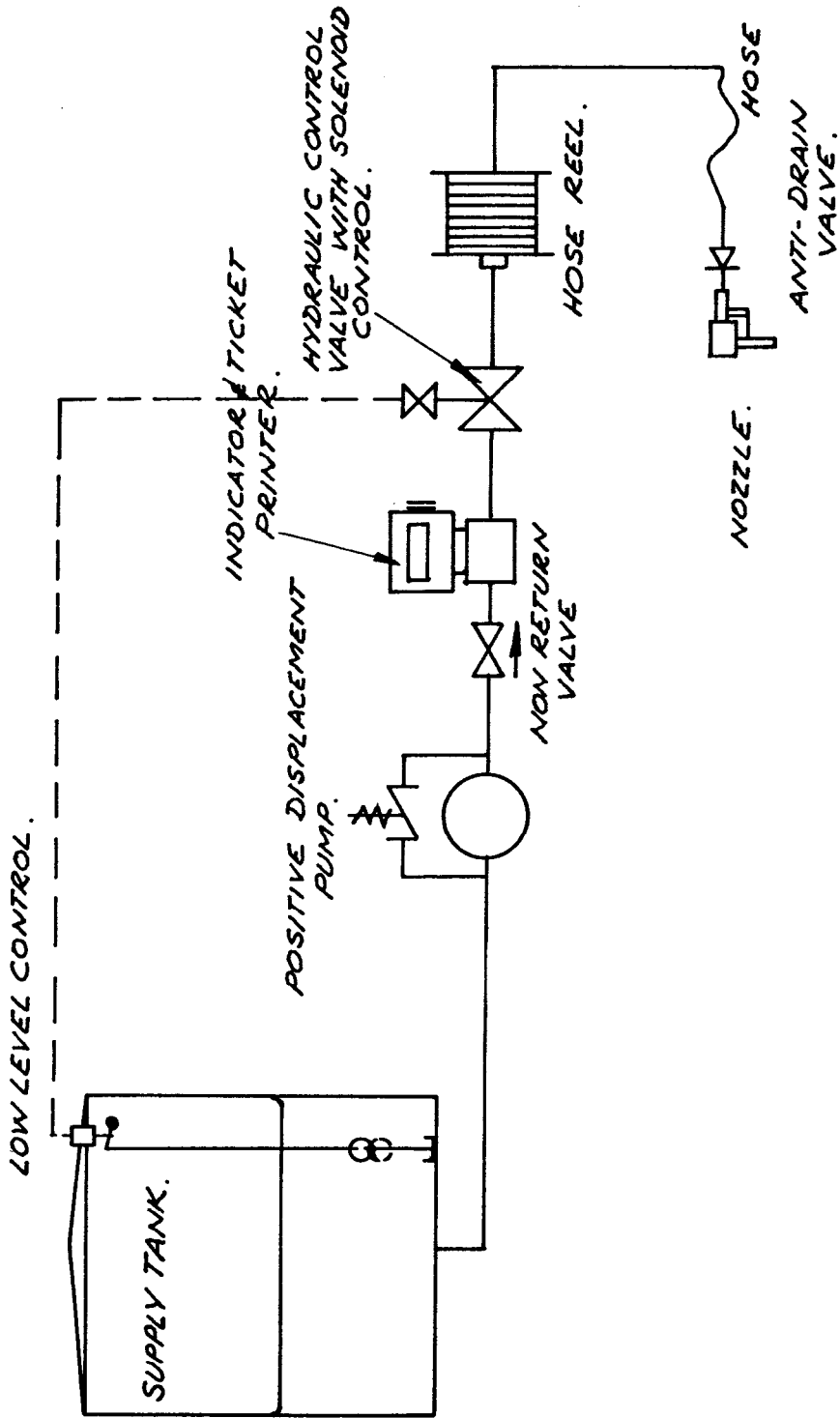

Neptune (Lubricating Oil) Flowmeter -- Schematic Diagram

FIGURE 5/6D/29 - 2



Neptune Type 442 Indicator, Set-stop Counter  
and Outlet-control Valve

29/10/76

FIGURE 5/6D/29 - 3

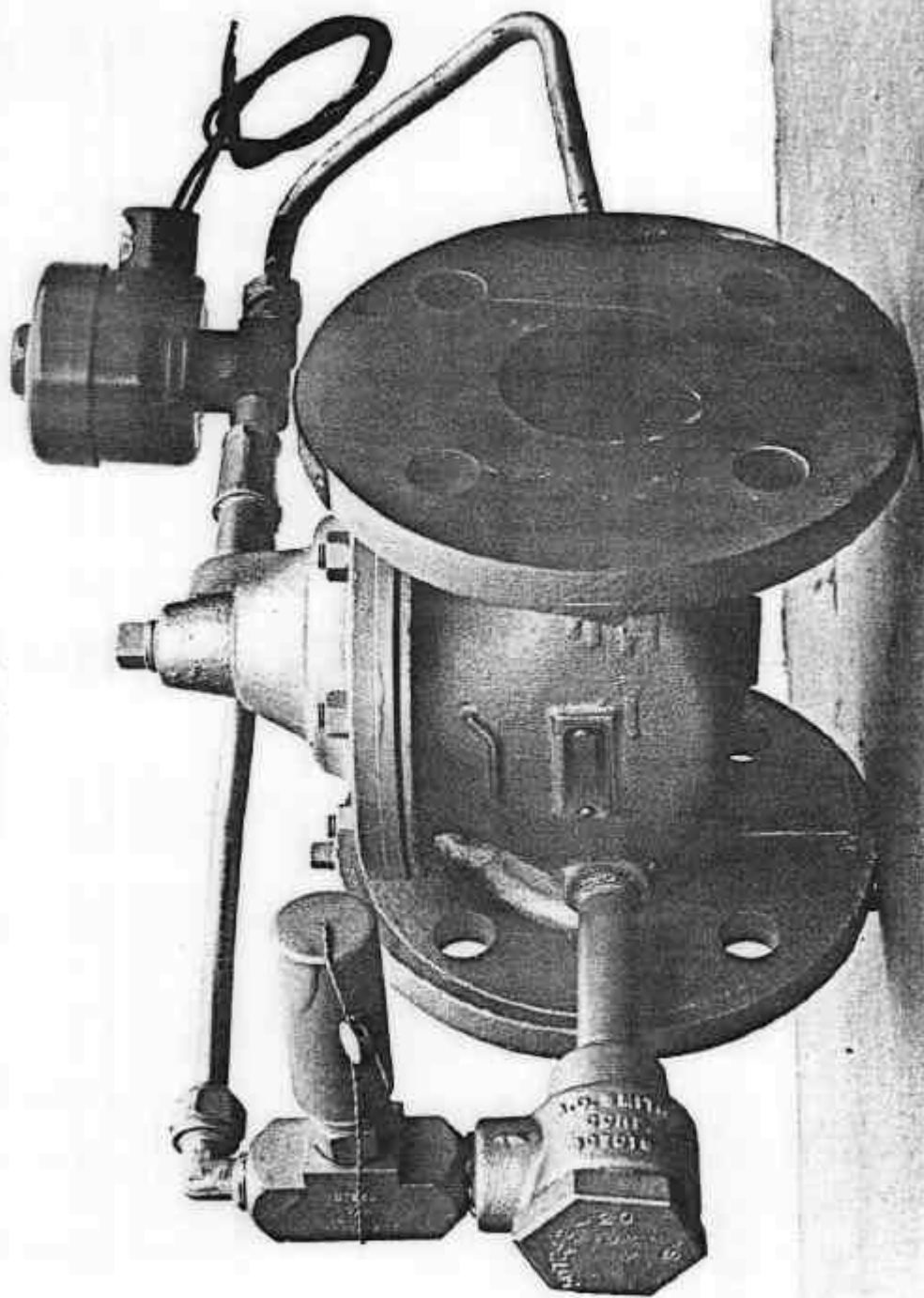

Electrically Controlled Hydraulic Shut-off Valve

29/10/76

FIGURE 5/6D/29 - 4

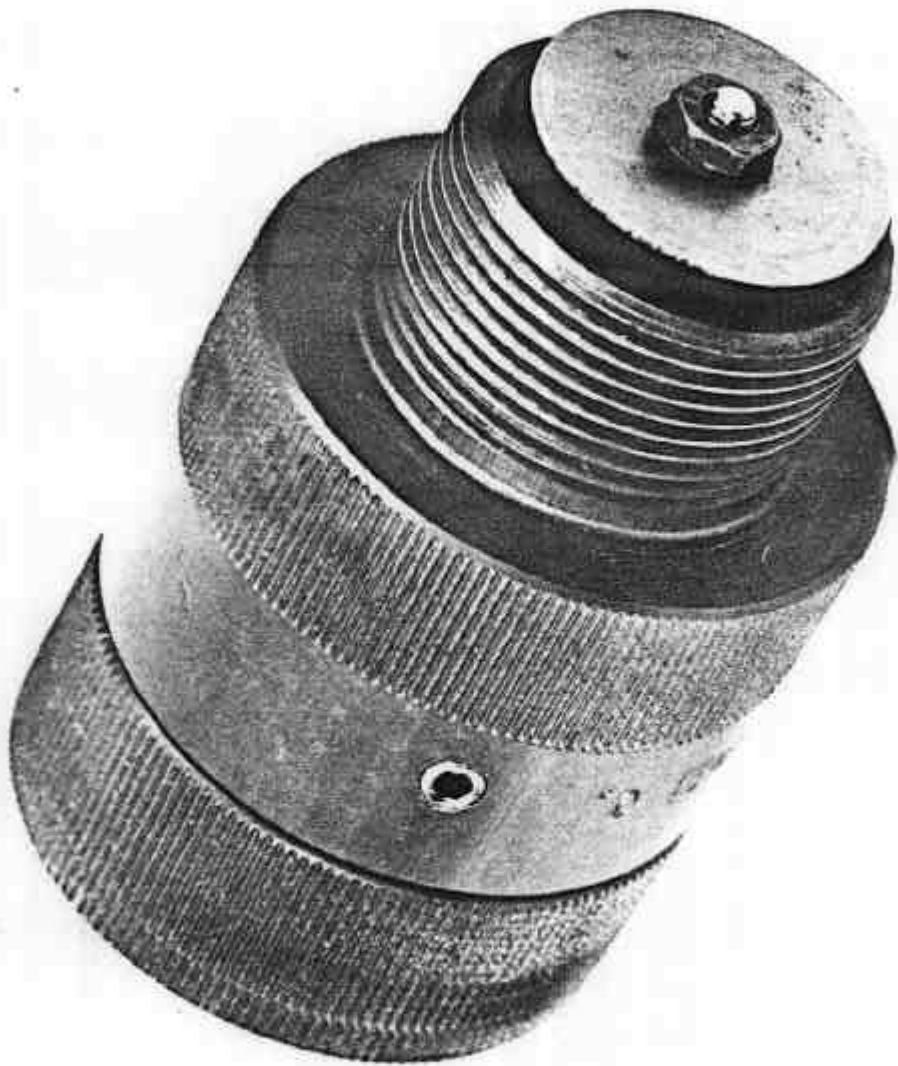

Anti-drain Valve

29/10/76

FIGURE 5/6D/29 - 5

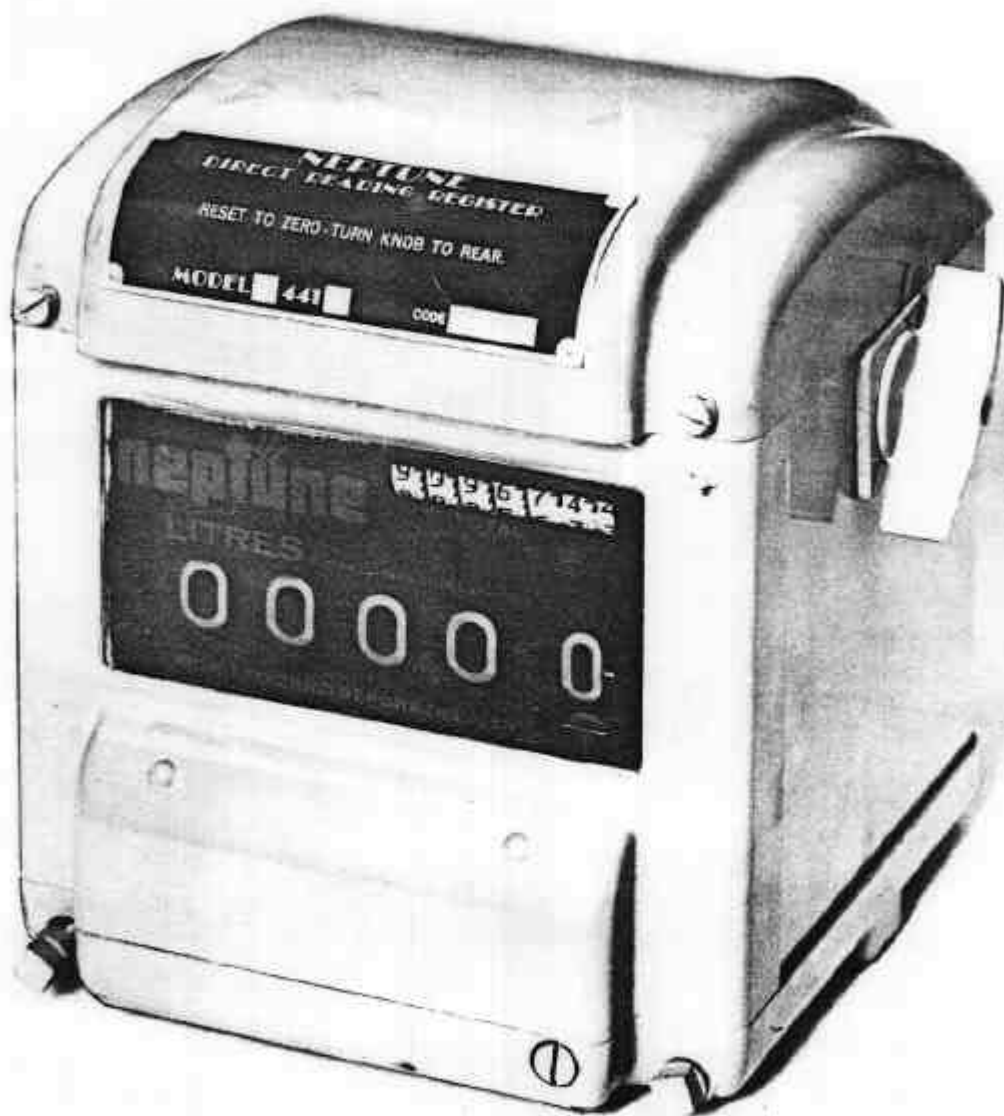

Neptune Type 441 Indicator

29/10/76



Neptune Type 443 Indicator and Ticket Printer



FIGURE 5/6D/29 - 7



Neptune Type 444 Indicator, Ticket Printer  
and Set-stop Counter

29/10/76

FIGURE 5/6D/29 - 8

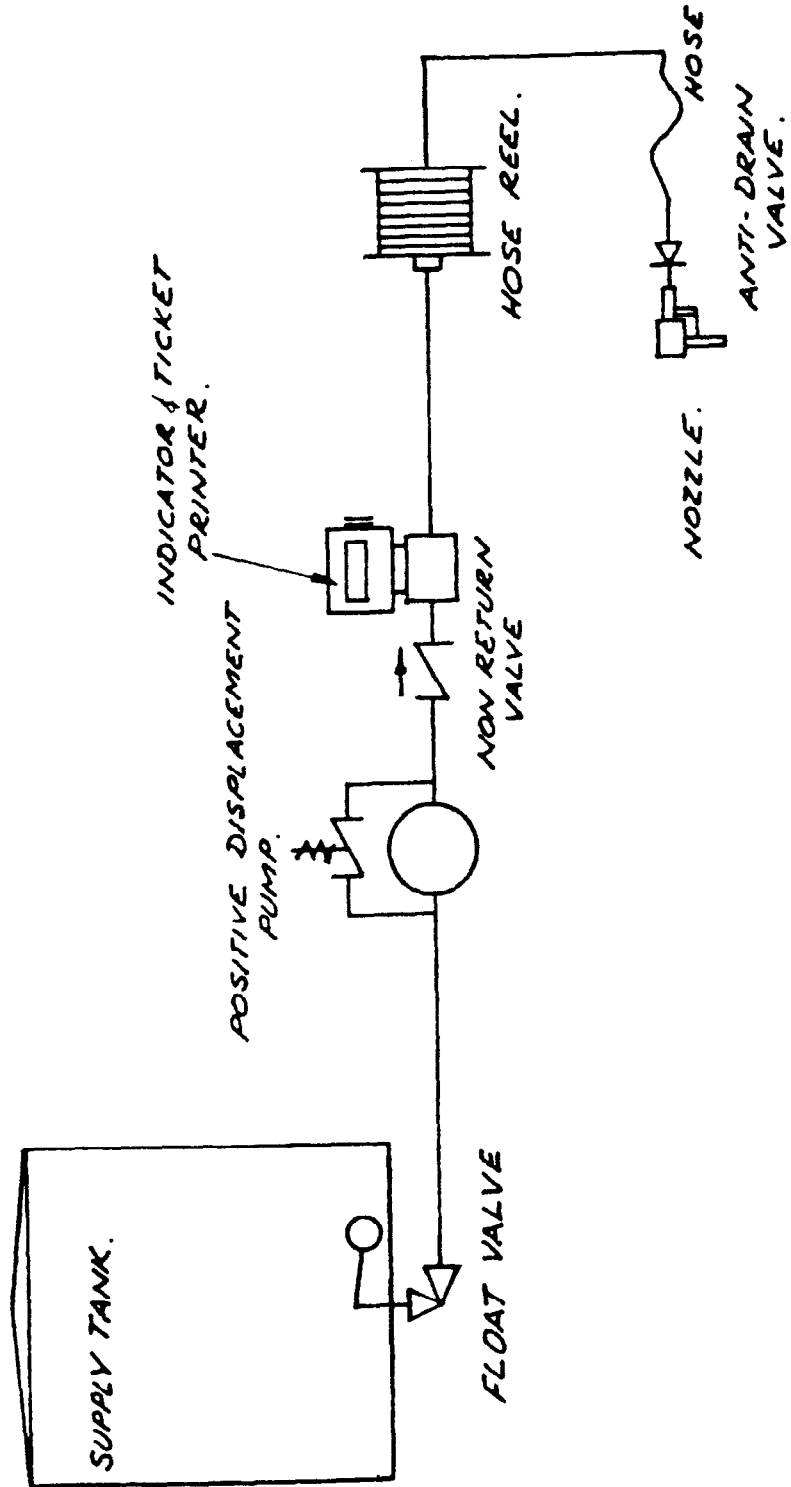

Neptune 38 mm Type 4 (Lubricating Oil) Flowmeter

- Schematic Diagram