

CERTIFICATE OF APPROVAL No 6/5/11

This is to certify that the pattern of the

Mercury Weighing Instrument Model 211 DA

submitted by Mercury Scale Co. Pty Ltd,
32 Dew Street,
Thebarton, South Australia, 5031,

has been approved under the Weights and Measures (Patterns of Instruments) Regulations as being suitable for use for trade.

Date of Approval: 19 August 1978

The pattern is described in Technical Schedule No 6/5/11 and in drawings and specifications lodged with the Commission.

The approval is subject to review on or after 1 September 1983.

All instruments conforming to this approval shall be marked with the approval number "NSC No 6/5/11".

Signed



Assistant Executive Officer



NATIONAL STANDARDS COMMISSION

TECHNICAL SCHEDULE No 6/5/11

Pattern: Mercury Weighing Instrument Model 211 DA

Submitter: Mercury Scale Co. Pty Ltd,
32 Dew Street,
Thebarton, South Australia, 5031.

Date of Approval: 9 August 1978

All instruments conforming to this approval shall be marked
"NSC No 6/5/11".

Description:

The pattern is a spring balance of capacity 10 kg by 0,02 kg scale intervals with a weight scale on each side of the instrument (see Figures 1 and 2). It is designed to be freely suspended.

The load receptor is loosely contained in a frame free to swing from a vertical bar connected to the resistant mechanism. The spring-resistant mechanism (see Figures 3 and 4) consists of two temperature-stable springs in parallel between two cross-arms. The top cross-arm is in two sections, pivoted at the ends, and adjustable in the centre by means of a zero screw. The lower arm supports the load receptor and by a rack drives the pinion carrying the indicator spindle.

Two air dampers are connected between the cross-arms.

Each weight reading face is marked:

III

Max	=	10 kg
Min	=	0,4 kg
d = e	=	0,02 kg



NATIONAL STANDARDS COMMISSION

NOTIFICATION OF CHANGE

VARIOUS CERTIFICATES OF APPROVAL

The following changes are made to the approval documentation for the approvals listed overleaf

submitted by Mercury Weighing and Control Systems Pty Ltd
 32 Dew Street
 Thebarton SA 5031.

In the Certificates and Technical Schedules listed, the following changes should be made:

- 1) The submittor should be changed to read;

 A & D Mercury Pty Ltd

 (the address remains unchanged)

- 2) Any Mercury instrument or component of an instrument approved in the documentation, may now also be known as "AND Mercury" or similar.

Signed

Executive Director

APPROVAL PATTERN**TYPE:** weighing instruments counter scales6/3/007 Model 92
6/3/008 Model 131**TYPE:** counter machines semi-self-indicating

6/4A/012 Model 304A

TYPE: counter machines freely-suspended < 30 kg (spring scales)

6/5/011 Model 211 DA

TYPE: weighing instruments non-self-indicating6/9A/001 Models 692 and 682
6/9A/004 Model 522D
6/9A/007 Model 211
6/9A/008 Model 600**TYPE:** weighing instruments self-indicating6/9C/005 Model 211D
6/9C/013 Up to 2500 lb or 1200 kg
6/9C/066 Model 522 AL
6/9C/067 Model SM100/479/522D
6/9C/081 Model SB-LP 1200
6/9C/088 Model 522D LT-10K**TYPE:** weighbridges self-indicating6/10B/040 Model WB-LT
6/10B/045A Model RVB-H20**TYPE:** automatic weighing instruments (except belt conveyors)

6/14B/012 Model HSD automatic hopper

TYPE: overhead weighing instrument (suspended load or receptor)6/18/005 With 211DA headwork
6/18/017 Model OHT 500**TYPE:** digital indicatorsS114 Model 579
S128 Model 1300
S132 Model 900
S161 Model AD4316
S199 Model AD-4321**TYPE:** load cellsS117 Interface model SM25-12 kg
S163 Transducers model B5112.1K
S221 HBM model TRT-50 (Mercury model TRT3K-50)

FIGURE 6/5/11 - 1



Mercury 211 DA

29/11/78

FIGURE 6/5/11 - 2



Mercury 211 DA Weight Reading Face

29/11/78

FIGURE 6/5/11 - 3

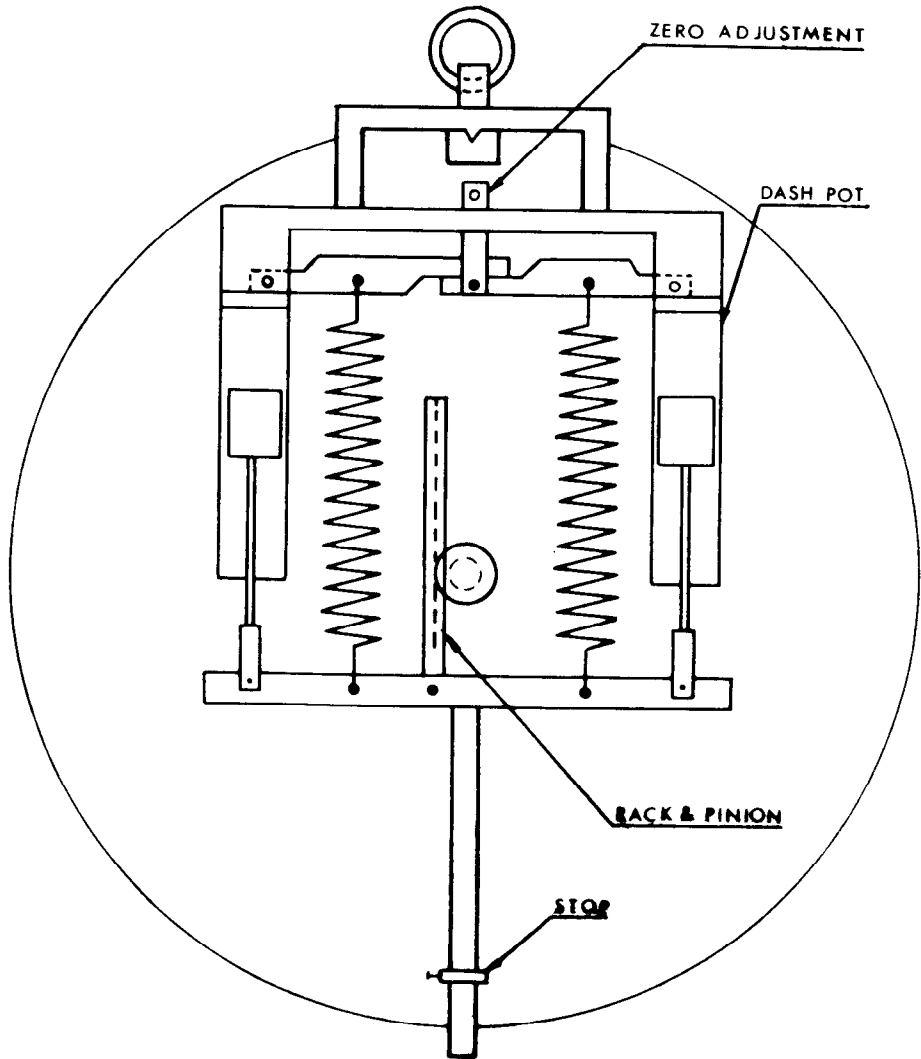

Mercury 211 DA Resistant Mechanism —
Schematic Diagram

29/11/78

FIGURE 6/5/11 - 4

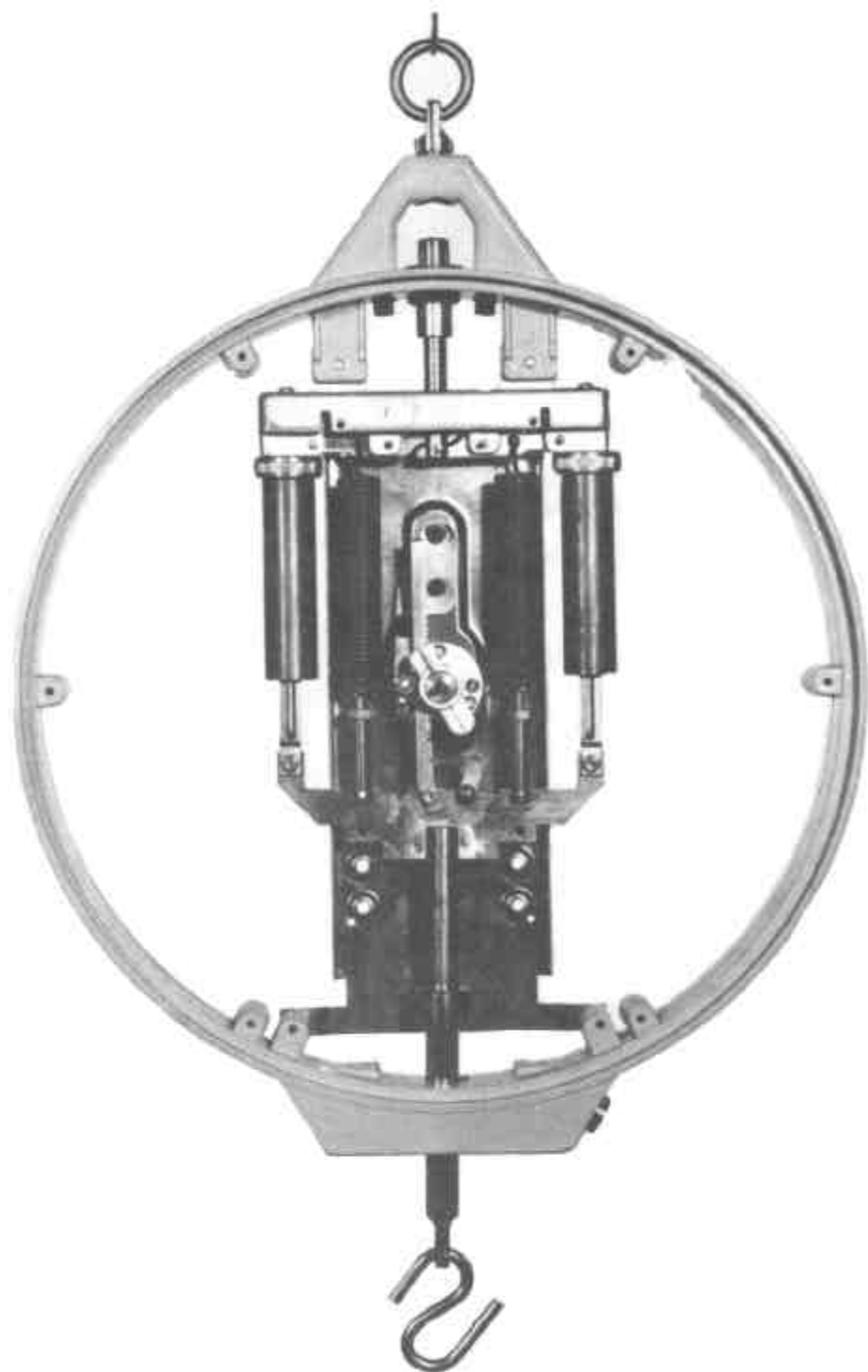

Mercury 211 DA — Resistant Mechanism

29/11/78