



Australian Government
National Measurement
Institute

Bradfield Road, West Lindfield NSW 2070

Notification of Change
Certificate of Approval No 8/74A
Change No 1

Issued by the Chief Metrologist under Regulation 60
of the
National Measurement Regulations 1999

The following changes are made to the approval documentation for the

NDA Engineering Model FHV 96-A_A-T Milk Tank

submitted by NDA Engineering Pty Ltd
709 Te Rapa Road
Hamilton
NEW ZEALAND.

In Certificate of Approval 8/74A dated 30 April 2003;

1. The Condition of Approval referring to the review of the approval should be amended to read:
“This approval becomes subject to review on 1 February **2013**, and then every 5 years thereafter.”
2. The FILING ADVICE should be amended by adding the following:
“Notification of Change No 1 dated 22 May 2008”

Signed by a person authorised by the Chief Metrologist
to exercise his powers under Regulation 60 of the
National Measurement Regulations 1999.

A handwritten signature in black ink, appearing to be 'J. G. T.', is located in the bottom right corner of the page.



National Standards Commission

12 Lyonpark Road, North Ryde NSW

Certificate of Approval

No 8/74A

Issued under Regulation 60
of the
National Measurement Regulations 1999

This is to certify that an approval for use for trade has been granted in respect of the

NDA Engineering Model FHV 96-A_A-T Milk Tank

submitted by NDA Engineering Pty Ltd
709 Te Rapa Road
Hamilton
NEW ZEALAND.

NOTE: This Certificate relates to the suitability of the pattern of the instrument for use for trade only in respect of its metrological characteristics. This Certificate does not constitute or imply any guarantee of compliance by the manufacturer or any other person with any requirements regarding safety.

This Certificate is issued upon completion of a review of NSC approval No 8/74.

CONDITIONS OF APPROVAL

This approval becomes subject to review on 1 February 2008, and then every 5 years thereafter.

Instruments purporting to comply with this approval shall be marked NSC No 8/74A and only by persons authorised by the submittor.

It is the submittor's responsibility to ensure that all instruments marked with this approval number are constructed as described in the documentation lodged with the Commission and with the relevant Certificate of Approval and Technical Schedule. Failure to comply with this Condition may attract penalties under Section 19B of the National Measurement Act and may result in cancellation or withdrawal of the approval, in accordance with the Commission's Document NSC P 106.

The Commission reserves the right to examine any instrument purporting to comply with this approval.

DESCRIPTIVE ADVICE

Pattern: approved 17 January 2003

- An NDA Engineering model FHV 96-A_A-T horizontal cylindrical refrigerated milk tank of 5200 L capacity incorporating a sight-gauge for the measurement of the volume.

Variant: approved 17 January 2003

1. Certain other models and capacities as listed in Table 1.

Technical Schedule No 8/74A describes the pattern and variant 1.

FILING ADVICE

The documentation for this approval comprises:

Certificate of Approval No 8/74A dated 30 April 2003
Technical Schedule No 8/74A dated 30 April 2003 (incl. Table 1, & Test Procedure)
Figures 1 and 2 dated 30 April 2003

Signed by a person authorised under Regulation 60 of the National Measurement Regulations 1999 to exercise the powers and functions of the Commission under this Regulation.



TECHNICAL SCHEDULE No 8/74A

Pattern: NDA Engineering Model FHV 96-A_A-T Milk Tank

Submittor: NDA Engineering Pty Ltd
709 Te Rapa Road
Hamilton NEW ZEALAND

1. Description of Pattern

An NDA Engineering model FHV 96-A_A-T horizontal cylindrical refrigerated milk tank of 5200 L maximum capacity (Figure 1 and Table 1) incorporating a sight-gauge for the measurement of the volume.

1.1 Details

- (i) The tank is a horizontal stainless steel cylinder sheathed in an outer casing of stainless steel; the cavity between is filled with insulating material.
- (ii) A single sight-gauge mounted in a vertical position is located in the vicinity of the outlet valve and comprises a transparent sight-tube fitted in a rigid stainless steel channel fixed to the side of the tank adjacent to a stainless steel scale. The scale has provision for a lead and wire seal to be attached to the scale mounting assembly. The sight-tube is made of transparent plastic.

The scale is graduated in 20 L increments.

A valve located at the bottom of the sight-gauge allows the milk in the sight-gauge to be drained without draining the contents of the tank.

- (iii) Levelling is effected by means of 4 adjustable legs with reference to the datum level marks permanently marked on the tank. The volume represented by the datum level marks is marked on the sight-gauge scale.

Each leg has provision for fixing to the floor, and sealing, after levelling.

- (iv) A top or front-mounted access hole is provided.
- (v) Provision is made for a CIP (clean-in-place) system for both the tank and the sight-gauge.
- (vi) A milk sampling valve may be fitted to the tank.

1.2 Verification/Certification Provision

Provision is made for a verification/certification mark to be applied.

1.3 Sealing Provision

Provision is made for the adjustable legs to be sealed after the tank has been levelled.

1.4 Markings

The following data is marked on the nameplate permanently attached to the instrument in a clearly visible location:

Manufacturer's mark, or name written in full	NDA Engineering Pty Ltd
Model number
Serial number
Pattern approval mark	NSC No 8/74A
Maximum capacity L

In addition, the volume represented by the datum level marks shall be marked on the on the sight-gauge scale.

2. Description of Variant 1

Certain models and capacities as listed in Table 1.

TABLE 1

Model Number	Maximum Capacity (litres)	Number of Legs	Scale Interval
FHV 96-A__A-*	5200	4	20
FHV 96-A__C-*	6600	4	20
FHV 96-B__A-*	7600	4	20
FHV 96-B__C-*	8600	4	20
FHV 96-B__E-*	10 500	4	50
FHV 96-B__F-*	11 900	4	50
FHV 96-B__G-*	12 600	6	50
FHV 96-B__H-*	14 000	6	50
FHV 96-C__A-*	15 600	4	50
FHV 96-C__B-*	17 800	4	50
FHV 96-C__C-*	18 800	6	50
FHV 96-C__D-* (#)	22 000	6	50
FHV 96-D__A-* (#)	22 000	6	50
FHV 96-D__B-*	24 900	6	50
FHV 96-D__C-*	26 300	6	50
FHV 96-D__D-*	30 600	6	50

* This is either a 'T' (denoting top entry access) or an 'E' (denoting front entry access).

(#) These models have different internal dimensions but the same capacity.

TEST PROCEDURE

Instruments should be tested in conjunction with any relevant tests.

Maximum Permissible Error at Verification/Certification

The maximum permissible error for milk tanks incorporating a sight-gauge is ± 1 scale interval.

THIS PAGE INTENTIONALLY BLANK

FIGURE 8/74A - 1

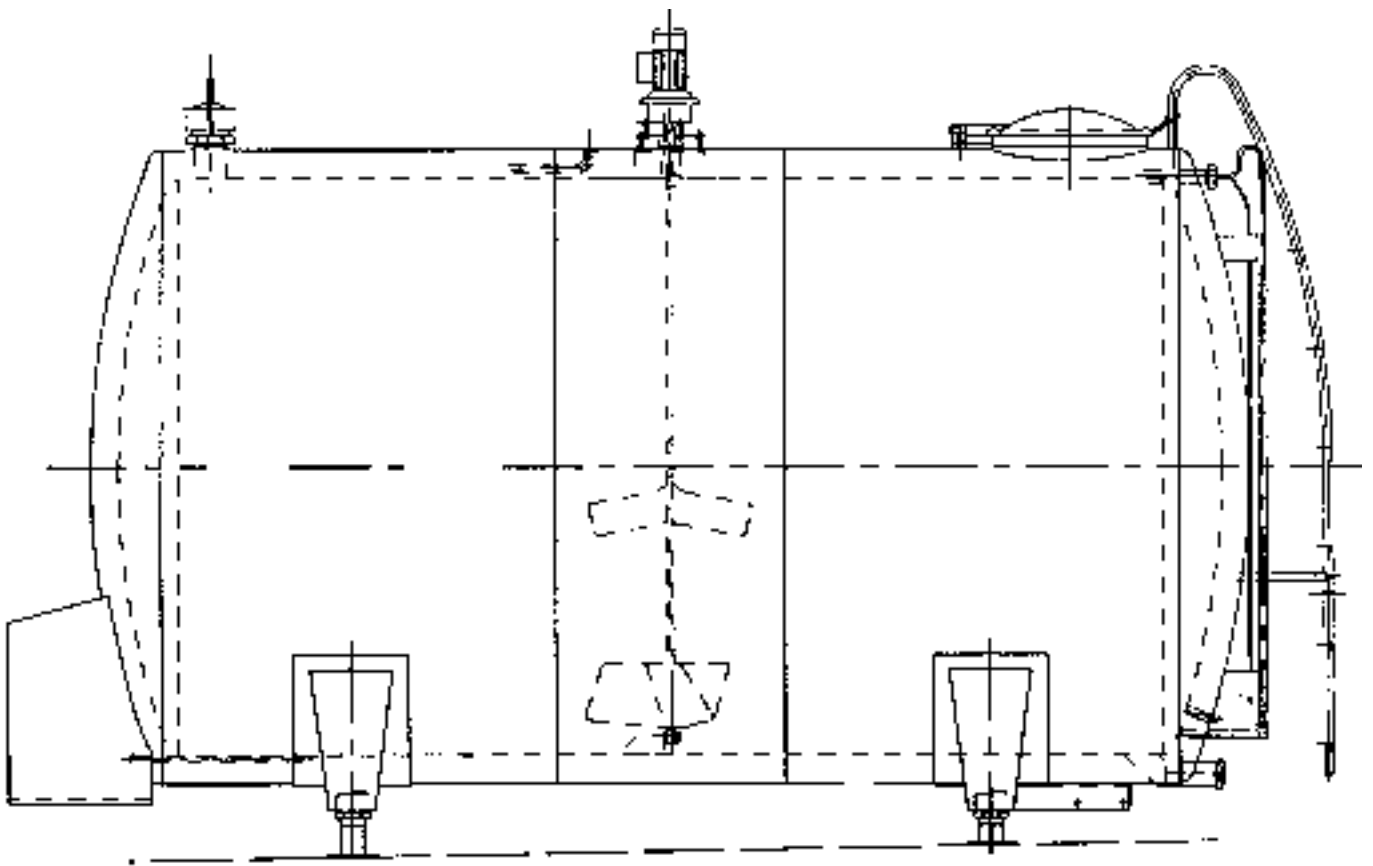

NDA Engineering Model FHV 96-A_A-T Milk Tank

8/74A
30 April 2003

FIGURE 8/74A - 2

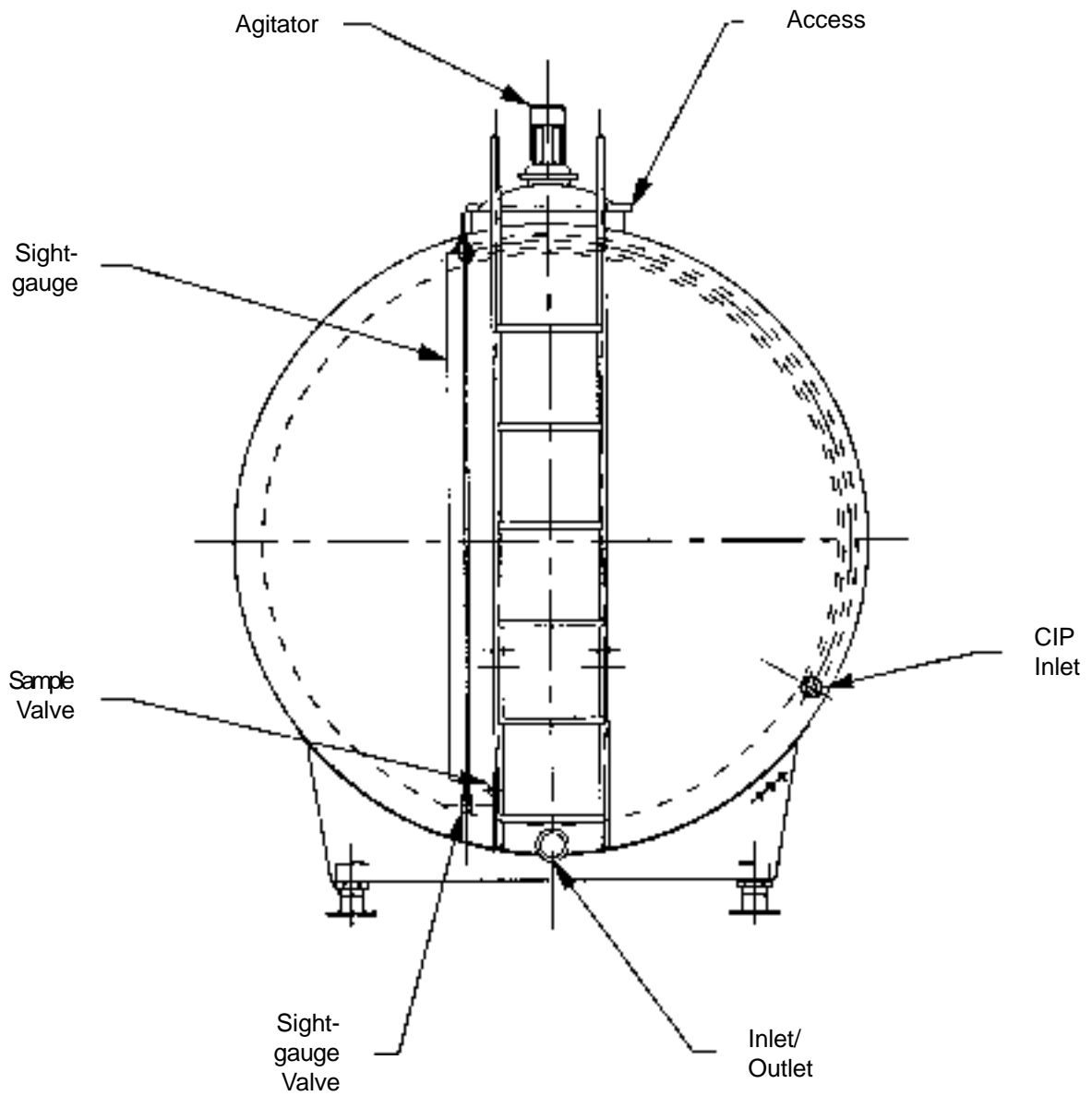

NDA Engineering Model FHV 96-A_A-T Milk Tank