

National Standards Commission



Certificate of Approval

No 8/40

Issued under Regulation 9
of the
National Measurement (Patterns of Measuring Instruments) Regulations

This is to certify that an approval for use for trade has been granted in respect of the

Zero Model 2100 Farm Milk Tank

submitted by Gulawarra Services Pty Ltd
42 Renver Road
Clayton VIC 3168.

Signed and sealed by a person authorised under Regulation 9 of the National Measurement (Patterns of Measuring Instruments) Regulations to exercise the powers and functions of the Commission under this Regulation.

A handwritten signature in black ink, appearing to read 'J. Birch', is written over the signature line.

CONDITIONS OF APPROVAL

This approval is subject to review on or after 1/10/95.
This approval expires in respect of new instruments on 1/10/96.

Instruments purporting to comply with this approval shall be marked NSC No 8/40 and only by persons authorised by the submittor.

It is the submittor's responsibility to ensure that all instruments marked with this approval number are constructed as described in the documentation lodged with the Commission and with the relevant Certificate of Approval and Technical Schedule. Failure to comply with this Condition may attract penalties under Section 19B of the National Measurement Act and may result in cancellation or withdrawal of the approval, in accordance with the Commission's Document 106.

The Commission reserves the right to examine any instrument or component of an instrument purporting to comply with this approval.

DESCRIPTIVE ADVICE

Pattern: provisionally approved 26/9/90 - approved 30/3/92

. A Zero model 2100 refrigerated farm milk tank of 2100 L capacity.

Variant: provisionally approved 26/9/90 - approved 30/3/92

1. In other capacities as listed in Table 1.

Technical Schedule No 8/40 describes the pattern and variant 1.

FILING ADVICE

Provisional Certificate of Approval No P8/40 dated 12/11/90 is superseded by this Certificate and may be destroyed.

The documentation for this approval now comprises:

Certificate of Approval No 8/40 dated 27/4/92
Technical Schedule No 8/40 dated 12/11/90 (incl. Table 1 and Test
Procedure)
Figure 1 dated 12/11/90



National Standards Commission

TECHNICAL SCHEDULE No 8/40

Pattern: Zero Model 2100 Farm Milk Tank.

Submitter: Gulawarra Services Pty Ltd
42 Renver Road
Clayton Victoria 3168.

1. Description of Pattern

- A Zero model 2100 horizontal cylindrical refrigerated farm milk tank (Figure 1) of 2 100 L maximum capacity incorporating a dipstick for the measurement of the volume of contents.

1.1 Details

- (i) The tank is provided with 4 adjustable legs, each having an integral footplate with provision for fixing the leg to the floor using dynabolts. One dynabolt at each end of the tank is drilled to allow a lead and wire seal to be attached after levelling.
- (ii) A top-mounted access hole is provided at the outlet end of the tank and incorporates a dipstick socket (Figure 1).
- (iii) The tank is in its prescribed position when it slopes towards the outlet at a gradient of not less than 1:220, and the liquid level at approximately half capacity corresponds with the level mark engraved on the rear of the dipstick and with the level marks on the external surface of each corner of the tank (Figure 1).
- (iv) The dipstick is graduated in accordance with Australian Standard AS 1187-1988.

1.2 Markings

The following data is marked on a nameplate permanently attached to the tank in a clearly visible location:

Manufacturer's name or mark
Model number
Serial number
NSC approval number
Maximum capacity

NSC No
..... L

The dipstick is marked with the following data:

Manufacturer's name or mark
Datum level
Serial number corresponding with the serial number of the tank
Scale interval

1.3 Verification Provision

Provision is made for a verification mark to be applied to both the tank and the dipstick.

2. Description of Variant 1

Other models with 4, 6 or 8 legs, and in capacities as listed in Table 1.

TABLE 1

Model	Maximum Capacity (litres)	Number of legs
2100	2 100	4
2250	2 250	4
2300	2 300	4
2800	2 800	4
4150	4 150	6
5350	5 350	8
5750	5 750	8

Approved Models and Capacities

TEST PROCEDURE

Instruments should be tested in conjunction with any relevant tests specified in the Inspector's Handbook.

Maximum Permissible Error at Verification/Certification

The maximum permissible error for all scale marks on the dipstick is ± 1 scale interval.

FIGURE 8/40 - 1

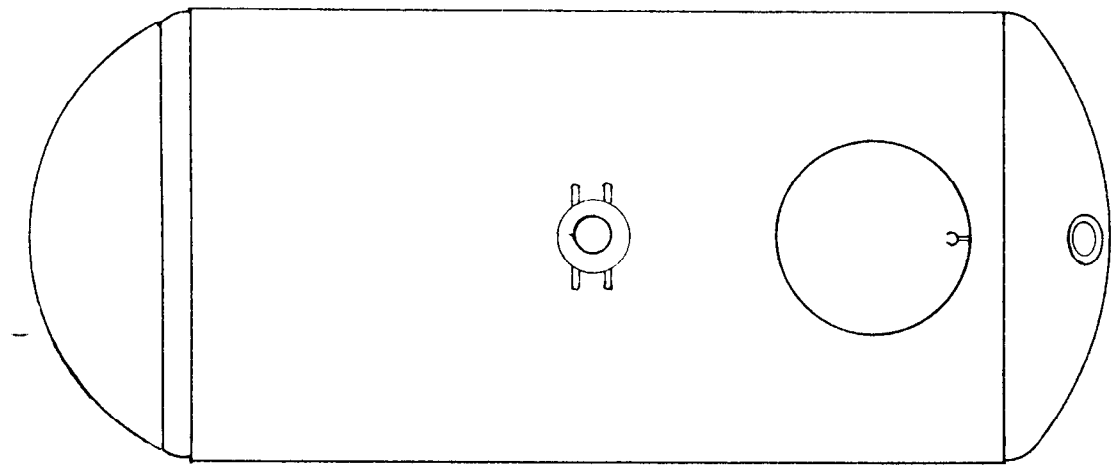

Plan

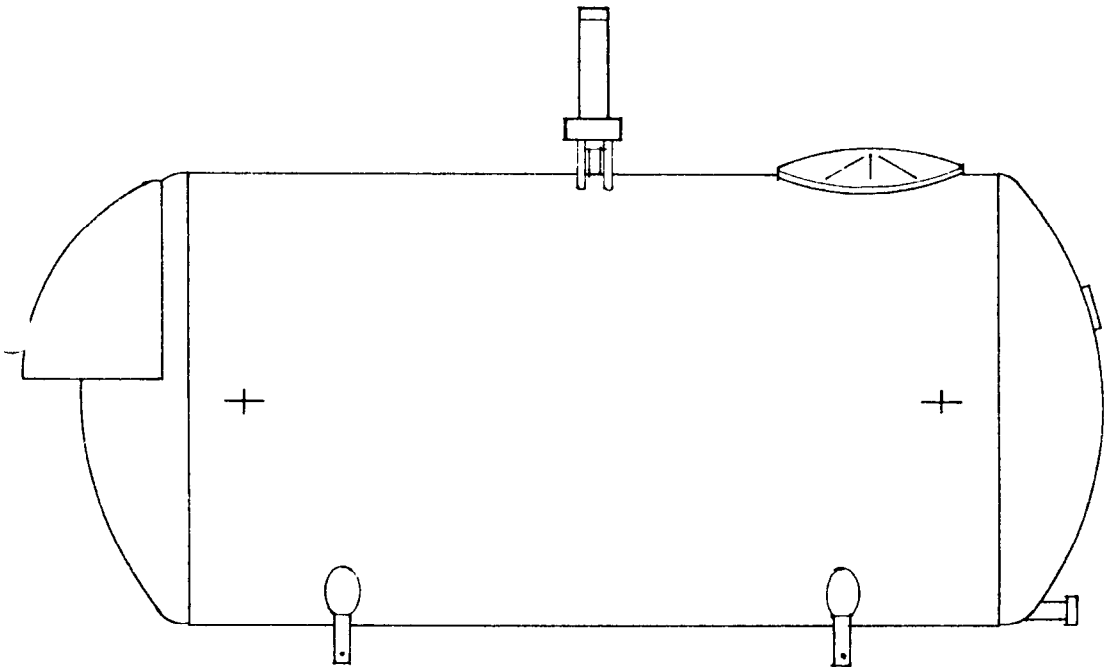

Side Elevation

Zero Model 2100 Farm Milk Tank