



NATIONAL STANDARDS COMMISSION

WEIGHTS & MEASURES (PATTERNS OF INSTRUMENTS) REGULATIONS

REGULATION 9

PROVISIONAL CERTIFICATE OF APPROVAL No P5/6B/60

This is to certify that an approval has been granted by the Commission that the pattern and variant of the

Pipeline/Loading Rack System with Liquid Controls Model M60-N-2 Flowmeter

submitted by Engineering Products Pty Ltd,
418-428 Burnley Street,
Burnley, Victoria, 3121,

are suitable for use for trade.

The approval of the pattern and variant is subject to review on or after 1/5/83.

All instruments purporting to comply with this approval shall be marked NSC No P5/6B/60.

Relevant drawings and specifications are lodged with the Commission.

Conditions of Approval

1. The maximum and minimum permissible flow rates are 2275 L/min and 455 L/min respectively.
2. When the range of flow rates in service exceeds 228 L/min, the maximum and minimum flow rates shall be marked on the data plate.

When the flow rate in normal conditions of use remains within $\pm 5\%$ of a nominal flow rate, the nominal flow rate shall be marked on the data plate.
3. The instrument is not used for liquefied gases.
4. The type of liquid for which the instrument is verified is marked on the data plate.
5. The system is designed so that gas cannot enter the meter.
6. Instruments are installed in the manner described in Technical Schedule No P5/6B/60.
7. Each system is tested in a manner approved by the Commission at intervals of approximately three months, or, if the throughput is less than 2 ML per month, at intervals of not less than 6 ML, such tests to be arranged by the submittor, and the results sent to the Commission.
8. In the event of unsatisfactory performance the approval may be cancelled.
9. The approval is liable for cancellation after one year from the date of approval if suitable test results are not received by the Commission.

10. The Commission reserves the right to inspect any installation incorporating a meter covered by this approval.

Signed

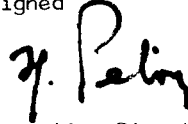

Executive Director

Descriptive Advice

Pattern: approved 6/4/82

- . Pipeline/loading rack system with Liquid Controls model M60-N-2 flowmeter.

Variant: approved 6/4/82

1. With rigid extension between the meter and indicator.

Technical Schedule No P5/6B/60 dated 3/5/82 describes the pattern and variant 1.

Filing Advice

Documentation for this approval consists of:

Certificate of Approval No P5/6B/60 dated 3/5/82
Technical Schedule No P5/6B/60 dated 3/5/82
Test Procedure No P5/6B/60 dated 3/5/82.



NATIONAL STANDARDS COMMISSION

TECHNICAL SCHEDULE No P5/6B/60

Pattern: Pipeline/Loading Rack System with Liquid Controls Model M60-N-2 Flowmeter

Submitter: Engineering Products Pty Ltd,
418-428 Burnley Street,
Burnley, Victoria, 3121.

1. Description of Pattern

1.1 Pipeline flowmeter

Refer to Figure 1.

The system comprises:

1.1.1

Supply tank.

1.1.2 Pump

Mounted lower than the minimum height of the liquid in the supply tank; the supply pipe from the tank has a continuous fall to the pump; provision is made for a pressure gauge to be connected to the suction side of the pump; if the pump is not for the exclusive use of the flowmeter, the flow rate through the meter must stay within the appropriate flow-rate range for all combinations of alternative uses of the output from the pump.

1.1.3

A non-return valve between the pump and the meter, or an arrangement of the components and the piping to keep the system full of liquid at all times.

*1.1.4

Strainer with air release head (Figures 3 and 4).

1.1.5

Liquid Controls model M60-N-2 flowmeter (Figures 3 and 4).

1.1.6

One of the following combinations of assemblies:

(a) Indicator model VR7887 (Figure 3).

or

(b) Ticket printer/indicator model VR7890 (Figure 4).

Note: A Liquid Controls preset indicator model D4100 series and Liquid Controls preset control valve model A-4610 may be fitted to (a) or (b).

* The strainer with air release head is not a part of the measuring instrument examined and approved by the Commission.

1.1.7

Flow rate control valve.

1.1.8

Outlet-control valve located downstream of the meter with no intermediate outlet.

1.2 Loading-rack Flowmeter System

This system is identical to the pipeline system except for the outlet which is replaced by one of the following:

Top-loading arrangement (Figure 2) - the highest point of the pipework forms a weir at a fixed level from which the delivery pipe drains to the outlet for all configurations of the loading arm whilst in operation; the outlet-control valve is installed at or upstream of the highest point and a syphon breaker is installed downstream of the weir to ensure complete draining of the pipework downstream of the weir,

OR

Bottom-loading arrangement - drybreak coupling located at the delivery point of the piping.

1.3 Features Common to Both Systems1.3.1 Marking

All instruments are marked with the following data, together in one location:

Manufacturer's name or mark	
Meter model	
Serial number	
NSC approval number	NSC No P5/6B/60
Maximum flow rate 2275 L/min)	(when operating over a range of more
Minimum flow rate 445 L/min)	than 228 L/min)
Nominal flow rate)	(when flow rate is within \pm 5% of
	nominal)
Type of liquid for which the instrument is verified	
Minimum delivery	

1.3.2 Sealing1.3.2.1

The indicator or ticket printer/indicator is sealed by passing a sealing wire through the attachment-mounting bolts terminating in a lead seal. The calibrator is sealed by a lead stamping plug (Figures 3 and 4).

1.3.2.2

The instrument data plate is sealed to the instrument or framework by a lead-stamping plug or by threading the indicator-sealing wire through a hole in the data plate.

1.4 Minimum Delivery

The following minimum deliveries are applicable:

100 L with indicator only;
 200 L with zero-start printer and indicator;
 400 L with accumulative-start printer and indicator.

2. Variant

1. With rigid extension between meter and indicator.

TEST PROCEDURE No P5/6B/60

1. The instrument should be tested with the liquid for which it will be used and which is marked on the data plate.

The maximum permissible errors at verification are:

- (a) $\pm 0.3\%$ for any flow rate when operating over a flow rate range of more than 228 L/min; (but within the marked maximum and minimum flow rates); or
 - (b) $\pm 0.15\%$ when operating at a flow rate within $\pm 5\%$ of nominal as marked on the meter.
2. The maximum permissible variation between indicators is 0.2 scale intervals.
 3. If a device is fitted to prevent the level of the liquid in the supply tank falling to the level of the pump, at least one delivery should occur during which the device stops the delivery. It will be necessary to refill the supply tank to finish the delivery into the proving measure. The effect on the measurement of the quantity delivered should not exceed 1% of the minimum delivery.

Note: This test should only be done where it could be expected that the low-level device may operate during a normal day's delivery.

4. Test delivery - if the test delivery is less than ten times the minimum delivery, the reading error of the indicator or the rounding error of the ticket printer is minimised by completing the delivery at a graduation line.

The following information shall be recorded for sending to the Commission:

- (a) NSC approval number
- (b) Installation address
- (c) Meter serial number
- (d) Identification of meter assembly in terms of pattern and variants described in this Schedule
- (e) Totaliser reading at beginning of test
- (f) Type of liquid
- (g) Temperature of liquid entering the meter
- (h) Information from the Weights and Measures inspection as to the calibration results recorded in 1. above.

FIGURE P5/6B/60 - 1

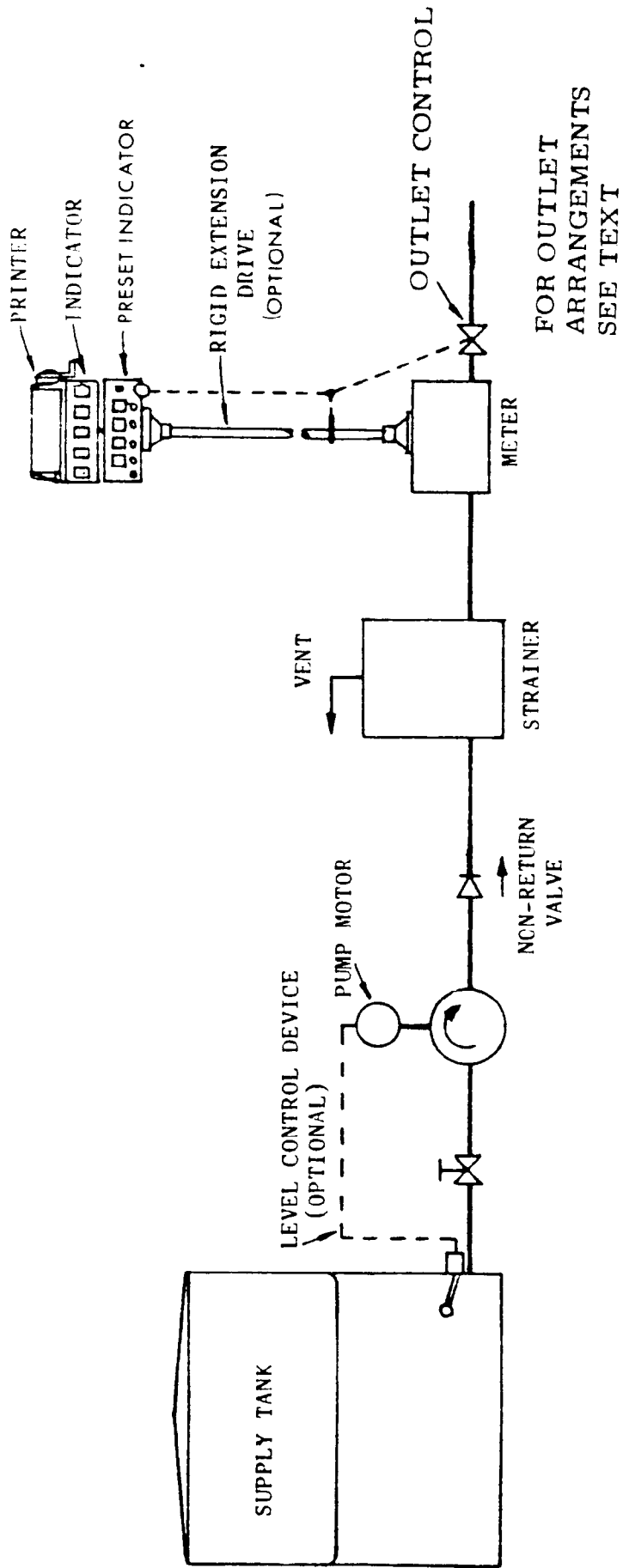

Pipeline Flowmeter - Schematic Diagram

FIGURE P5/6B/60 - 2

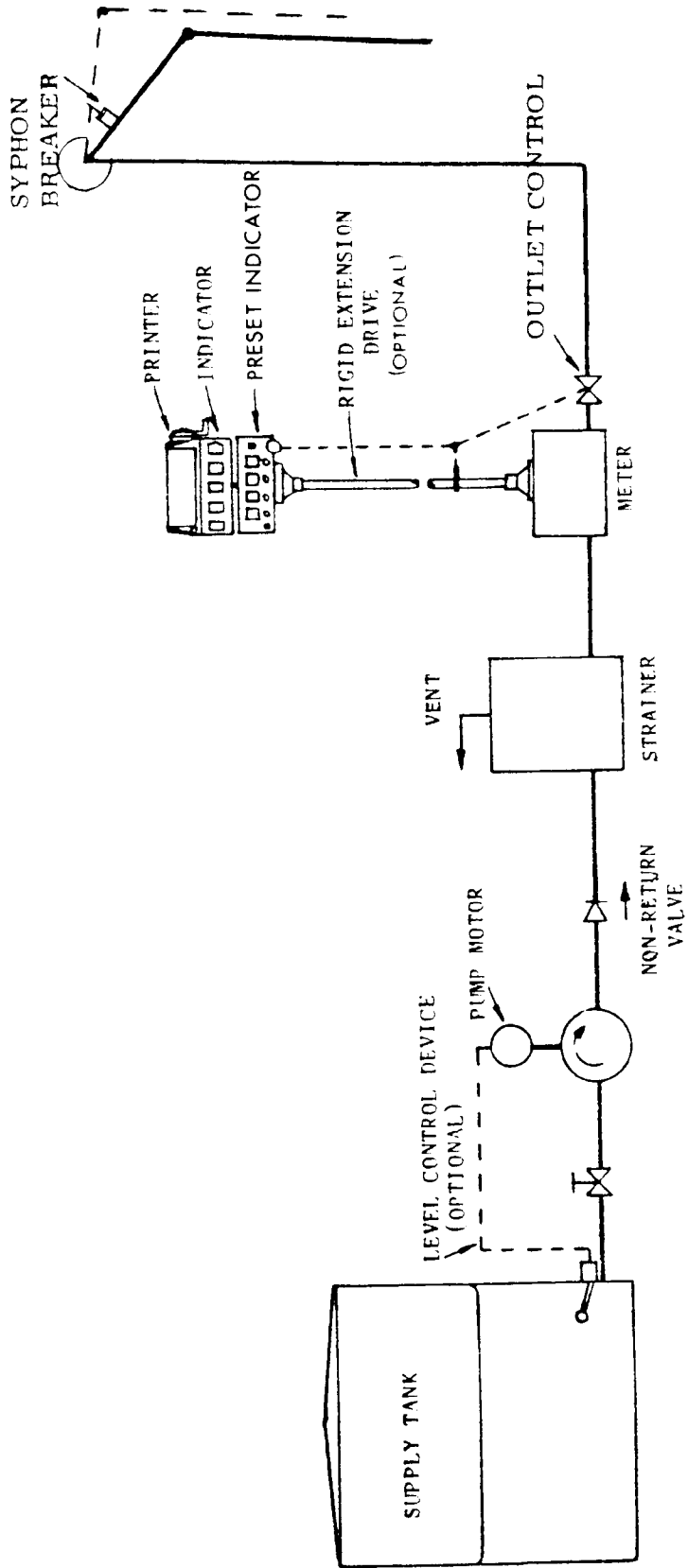

Loading-rack Flowmeter - Schematic Diagram

FIGURE P5/68/60 - 3

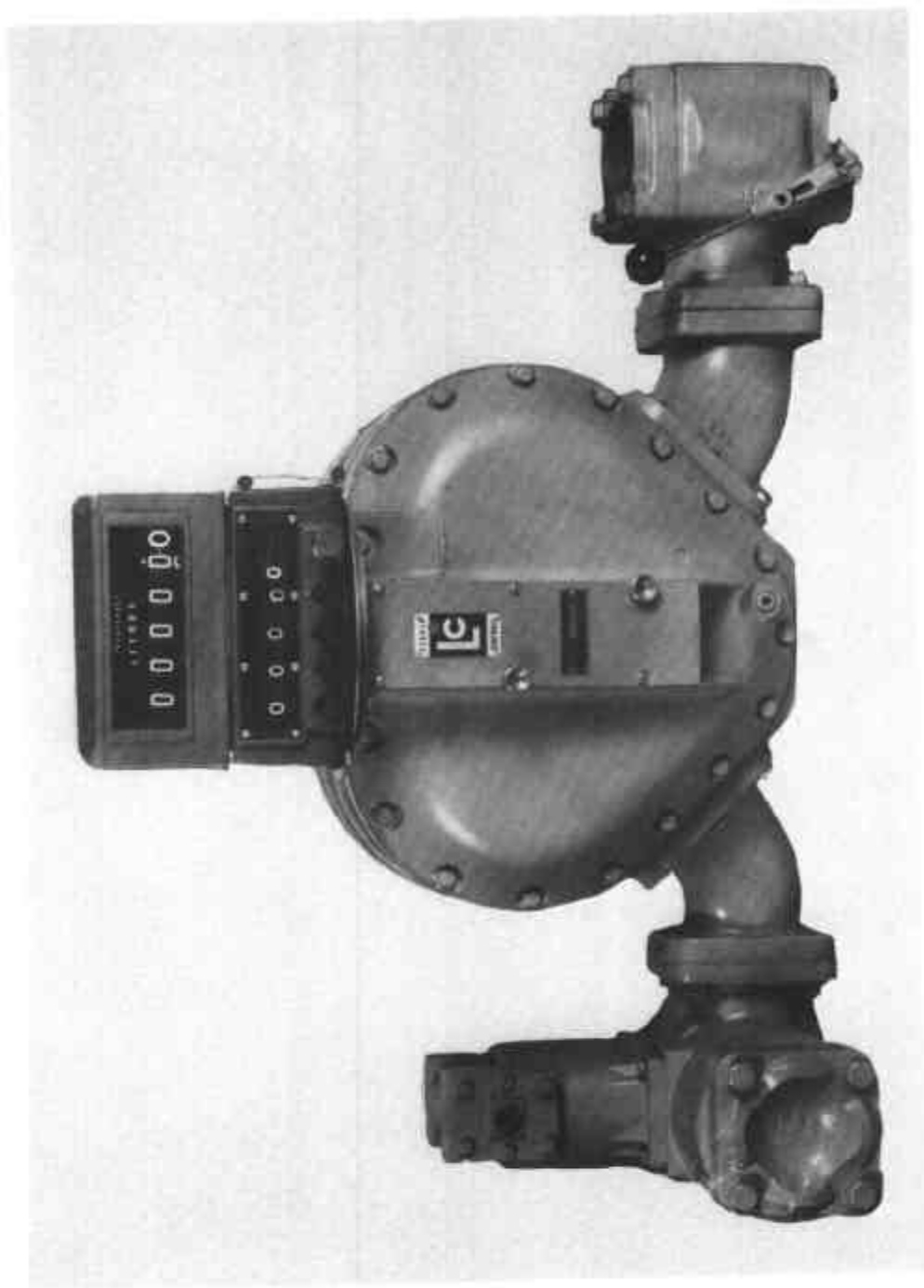

Indicator Model 1 VR7867 With Preset

FIGURE P5/65/60 - 4

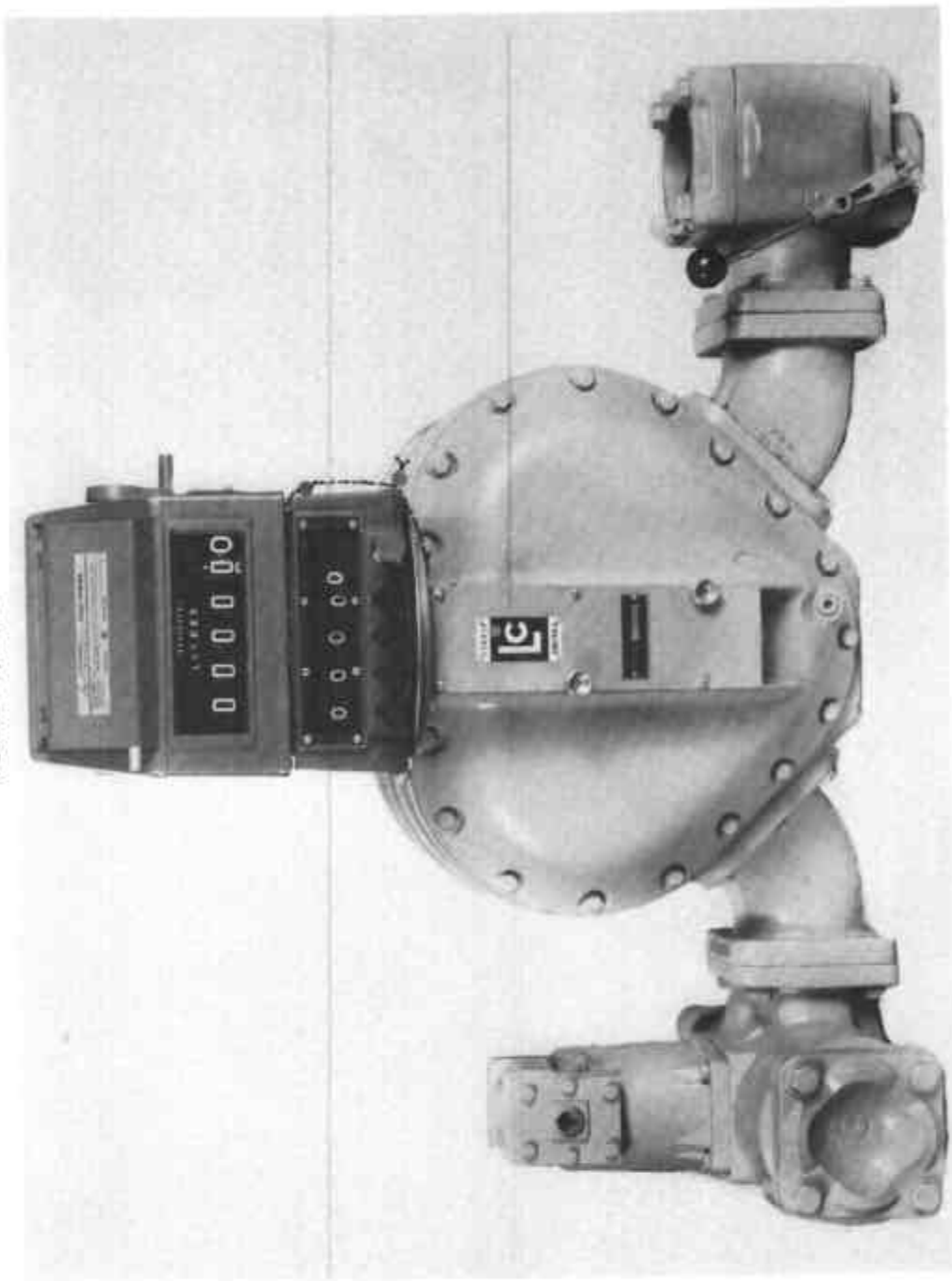

Ticket Printer/Indicator Model VR7890 With Preset